

**Kifix**<sup>®</sup>  
G R O U P  
G R U P O

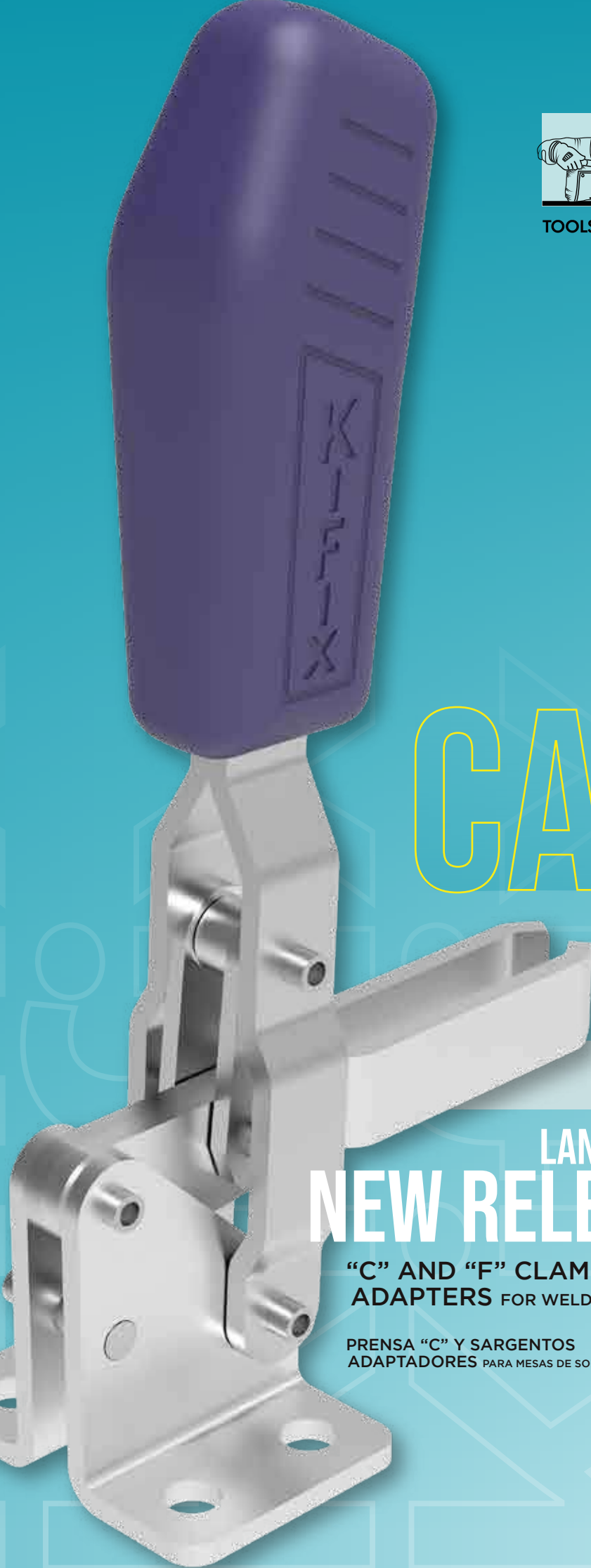

KIFIX CATALOGO  
KIFIX  
CATALOG  
2024

LANZAMIENTOS  
**NEW RELEASES**

**"C" AND "F" CLAMPS  
ADAPTERS FOR WELDING TABLES**

PRENSA "C" Y SARGENTOS  
ADAPTADORES PARA MESAS DE SOLDADURA

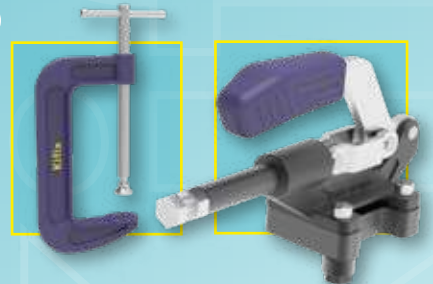

SINCE 2004  
DESDE EL 2004

## THE KIFIX

Headquartered in Caxias do Sul, in the state of Rio Grande do Sul, our company has been dedicated to manufacturing toggle clamps since 2004. We offer more than 700 high quality products, serving various industrial sectors, such as tool shops, metalworks, metallurgical industries, furniture, chemical, cosmetic, food, automobile, auto parts, among others.

In 2022, we expanded our operations by introducing the laser cutting service, taking advantage of the opportunity provided by the acquisition of a machine with advanced technology. Initially focused on cutting parts for our clamps, we realized the potential of this service and, in 2022, we established a dedicated sector to run our second business unit.

The following year, in 2023, we evolved into a business group by incorporating another business unit. This expansion was achieved through the distribution of Siegmund in Brazil, a world-renowned German company in the manufacture of welding tables and accessories. As official distributors in Brazil, through Kifix Tools, we consolidate our presence in the market by offering high quality products, agility and specialized solutions for your process.

## A KIFIX

Con sede en Caxias do Sul, en el estado de Rio Grande do Sul, nuestra empresa se dedica a la fabricación de prensas de fijación rápida desde 2004. Ofrecemos más de 700 productos de alta calidad, atendiendo a diversos sectores industriales, como taller de herramientas, metalúrgico, metalúrgico, industrias, mueblera, química, cosmética, alimentaria, automotriz, autopartes, entre otras.

En 2022 ampliamos nuestras operaciones introduciendo el servicio de corte por láser, aprovechando la oportunidad que nos brinda la adquisición de una máquina con tecnología avanzada. Inicialmente centrados en cortar piezas para nuestras prensas, nos dimos cuenta del potencial de este servicio y, en 2022, establecimos un sector dedicado para gestionar nuestra segunda unidad de negocio.

Al año siguiente, en 2023, evolucionamos a grupo empresarial incorporando otra unidad de negocio. Esta expansión se logró a través de la distribución en Brasil de Siegmund, empresa alemana de reconocimiento mundial en la fabricación de mesas y accesorios de soldadura. Como distribuidores oficiales en Brasil, a través de Kifix Tools, consolidamos nuestra presencia en el mercado ofreciendo productos de alta calidad, agilidad y soluciones especializadas para su proceso.



\*\*The images in this catalog are illustrative and serve to identify the product. Kifix reserves the right to change without prior notice.

\*\*Las imágenes de este catálogo son ilustrativas y sirven para identificar el producto. Kifix se reserva el derecho de modificar sin previo aviso.

## pag 06 Vertical Hold-Down Toggle Clamp

Prensa Rápida Vertical

KF-718  
KF-631  
KF 010 / KF-012 / KF-017 / KF-018 / KF-016 / KF-011 / KF-111  
KF-017 T  
KF-010F / KF-012F / KF-019 / KF-211 / KF-311 / KF-411  
KF-615 / KF-616 / KF-641 / KF-066 / KF-845 / KF-875  
KF-017 DS A / KF-011 DS A / KF-011 DS A JD / KF-111 DS A  
KF-211 DS A / KF-311 DS A / KF-411 DS A  
KF-MP / KF-JD  
KF-725 / KF-825  
KFU

## pag 17 Horizontal Hold-Down Toggle Clamp

Prensa Rápida Horizontal

KF-105 / KF-106 / KF-107 / KF-152 / KF-732 / KF-511 / KF-512 / KF-521 / KF-522 / KF-532 / KF-534  
KF-106 F / KF-107 F / KF-152 F / KF-312 F / KF-522 F / KF-531 F  
KF-531 / KF-541 / KF-312 / KF-712 / KF-523 / KF-722 / KF-533  
KF-102 / KF-101 / KF-103 / KF-104 / KF-515

## pag 24 Reinforced Horizontal Clamp

Prensa Horizontales Reforzadas

KF-524 D / KF-525 D / KF-527 D / KF-528 D

## pag 25 Pull Action Latch Clamp

Prensa Rápida de Gancho

KF-310 / KF-314 / KF-326 / KF-320  
KF-233 / KF-643 / KF-743 / KF-133 / KF-843 / KF-943 / KF-143  
KF-033 / KF-353 / KF-153 / KF-453 / KF-553  
KF-063 / KF-163 / KF-263 / KF-423 / KF-433 / KF-443 / TKF-473  
KF-330 / KF-350 / KF-340 / KF-375 / KF-385  
KFC3 / KFC4 / KFC5

## pag 31 Pull Action Latch Clamp with Strap

Prensa Rápida de Gancho con Correa

KF-233 CT / KF-743 CT / KF-843 CT

## pag 32 Straight Line Action Clamp

Prensa Rápida de Pistón

KF-305 / KF-405 / KF-505 / KF-605 / KF-067  
KF-061 / KF-057 / KF-051 / KF-054 / KF-053 / KF-052 / KF-056

## pag 34 Straight Line Action Clamp with Handle

Prensa Rápida de Pistón con Mango

KF-025 AL / KF-057 AL / KF-054 AL / KF-053 AL / KF-052 / KF-056

## pag 35 Straight Line Action Clamp with Turning

Prensa Rápida de Pistón con Giratório

KF-007 G

## pag 36 Straight Line Action Clamp Frontal

Prensa Rápida de Pistón con Fijación Frontal

KF-005 / KF-006 / KF-007 / KF-009 / KF-015 / KF-025 / KF-035  
BASES "L" for Straight Line Action Frontal / desplazamiento axial con fijación frontal

## pag 37 Straight Line Action Clamp Square Plunger

Prensa Rápida de Pistón Cuadrado

KFKT-012

pag **38** **Double Clamps**  
**Prensa Doble**  
KF-686 D / KF-687 D / KF-686 H

pag **39** **Variable Stroke**  
**Husillo Rápido**  
KFRL / KFRF

pag **39** **Handles**  
**Tiradores**  
KFM-6 / KFM-8 / KFM-10 / KFM12 / KFM-16

pag **40** **Carver Clamp**  
**Prensa Sargento**  
KFS-150 / KFS-300

pag **40** **Compressor Clamp**  
**Prensa de Compresión**  
KF-035 34 / KF-035 60 / KF-035 3660 / KF-035 100

pag **41** **Pneumátic Clamp**  
**Prensa Neumático**  
KF-012 P / KF-017 P / KF-011 P / KF-111 P  
KF-057 P / KF-052 P / KF-066 P  
KF-019 P / KF-311 P / KF-411 P  
KF-718 P

pag **44** **Power Clamp**  
**Prensa Neumático Pesado**  
KFP-L40 / KFP-L63

pag **45** **Hinges and Latch**  
**Pestillo y bisagras**  
KFD-14 / KFD 19  
KFT-10 / KFT-14

pag **45** **Squeeze Action Clamp**  
**Alicates**  
KFA-300  
KF-325 / KFA-25 / KFA-35 / KFA-45 / KFA-70 / KFA-90 / KFA-100 / KFA-150

pag **47** **Handle**  
**Mango**  
KF-AL

pag **47** **Spindle**  
**Tornillo de Apriete**  
PC / PF  
PP / PS / PSB / PA / ARP / ARB / PB / BRP / BRB / BAP / PBC / BRPC  
PSD / PBD

pag **50** **Adapters for Welding Tables**  
**Adaptadores para mesas de soldadura**  
MS BE / MS FU / MS BV / MS BH / KFA MS / KFA L MS

pag **54** **“C” and “F” Clamps**  
**Prensa “C” y sargentos**  
KFSG / KFSR / KFSC



# MECHANISM MECANISMO

The toggle clamping system has received various designations over time, for example: Clip, manual press, fastener, clamp (CLAMP -USA).

This mechanism consists of a three-point joint known as "knee or elbow action", which provides a mechanical lock (see figure below) that generates a retaining force contrary to the applied force, which is released only if actuated purposefully.

In order to avoid random unlocking, we also offer quick coupling clamps with safety locks.

El sistema de fijación rápida recibió denominaciones variadas a través del tiempo, por ejemplo: presilla, prensa manual, fijador, brida (CLAMP -USA).

Este mecanismo consiste en una articulación de tres puntos conocida como "acción de rodillas o codo", la cual, proporciona un bloqueo mecánico (vea la siguiente figura) que genera una fuerza de retención contraria al esfuerzo aplicado y que solo se desbloquea si es activada a propósito.

Para evitar el desbloqueo aleatorio, dejamos disponible también bridas de prensa rápida con bloqueo de seguridad.

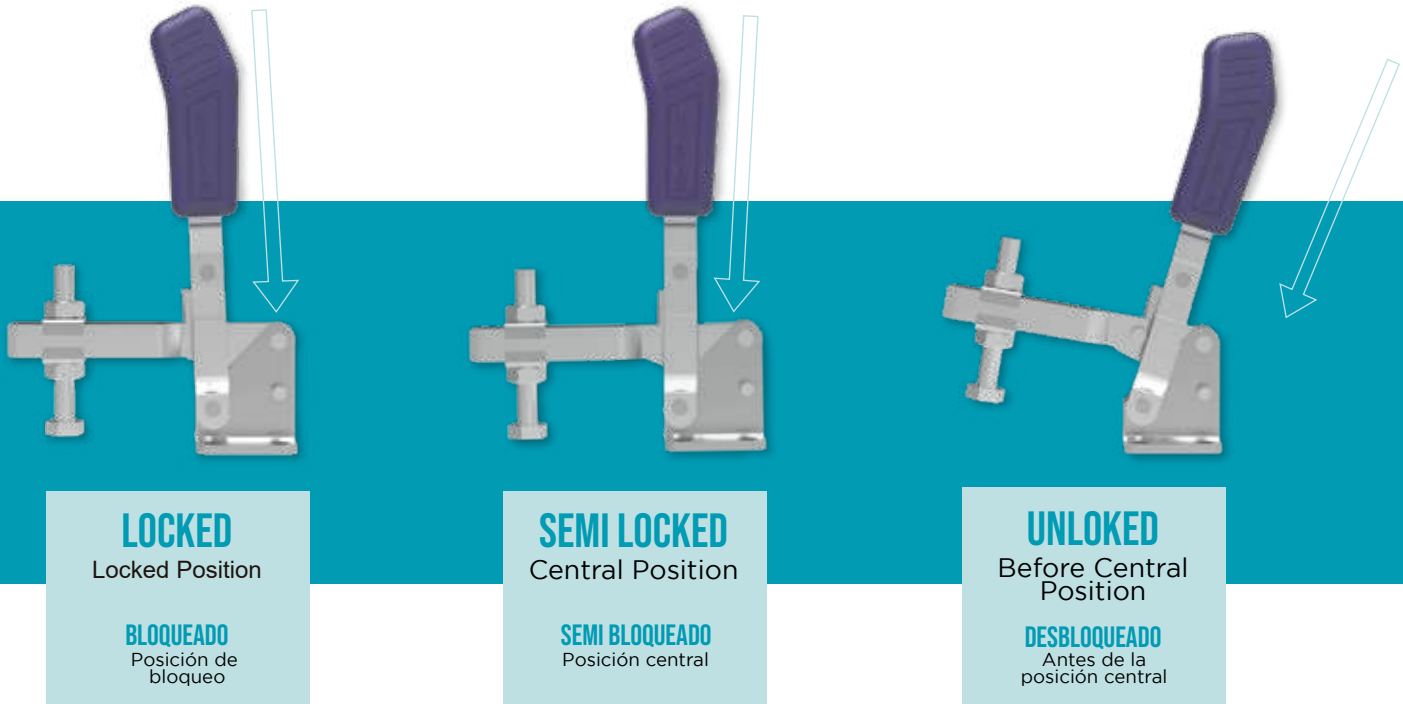

# RETENTION FORCE FUERZA DE RETENCIÓN

The retention force is proportional to the distance of the turning point (A) to the point of attachment of the tip (B / C).

The greater the distance between point A and the point of attachment of the tip, the least the retention force.

The retention force is proportional to the distance of the turning point (A) to the point of attachment of the tip (B / C).

Distance AC: 135mm F1 (specified in the catalog) = 680 Kgf

Distance AB: 90mm F2 =  $680 \times \frac{AC}{AB} = 680 \times \frac{135}{90} = 1.020$  Kgf.

La fuerza de retención es proporcional a la distancia del punto de giro (A) al punto de fijación de la puntera (B/C).

A mayor distancia entre el punto A y el punto de fijación de la puntera, menor será la fuerza de retención del fijador.

La fuerza de retención es proporcional a la distancia del punto de giro (A) al punto de fijación de la puntera (B/C).

Distancia AC: 135mm F1 (especificado en el catálogo) = 680 Kgf.

Distancia AB: 90mm F2 =  $680 \times \frac{AC}{AB} = 680 \times \frac{135}{90} = 1.020$  Kgf.

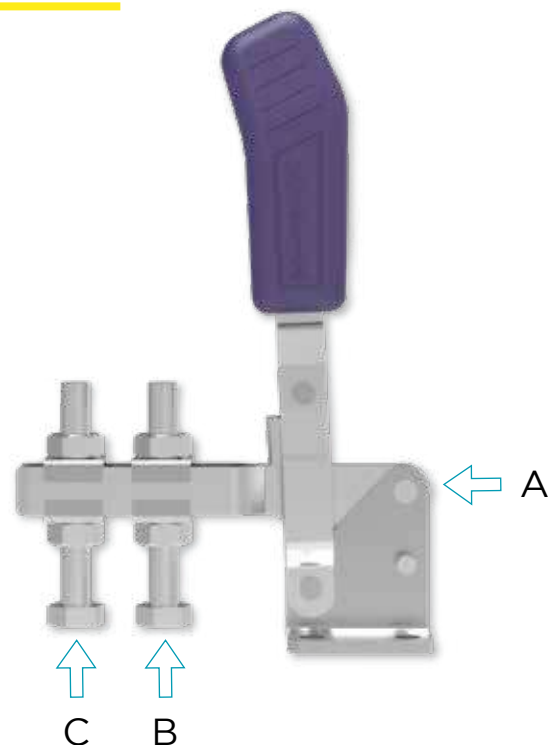

# CABLE COLORS COLORES DE CABLES

We have color options for the clamp cables, blue (standard color), black, red, orange and green. And for handle model cables we have the colors blue (standard), black and red.

Tenemos opciones de color para los cables de las grapas, azul (color estándar), negro, rojo, naranja y verde. Y para los cables modelo mango disponemos de los colores azul (estándar), negro y rojo.



Blue (standart)  
Azul (estándar)



Black  
Negro



Red  
Rojo



Orange  
Naranja



Green  
Verde



Black  
Negro



Red  
Rojo



Blue (standart)  
Azul (estándar)

# SPECIAL PROJECTS PROYECTOS ESPECIALES

We work with the development of new projects or adaptation of existing products, according to the client's needs, being able to elaborate something specific for each business.

Trabajamos con el desarrollo de nuevos proyectos o adaptación de productos existentes, según las necesidades del cliente, pudiendo elaborar algo específico para cada negocio.



KF-011 DS A



Adaptation  
Adaptación

KF-011 DS A JD

# VERTICAL HOLD-DOWN TOGGLE CLAMP PRENSA RÁPIDA VERTICAL

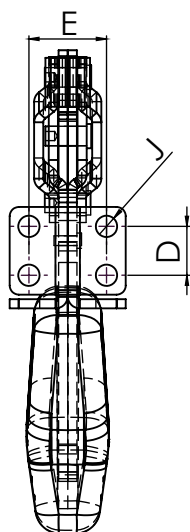
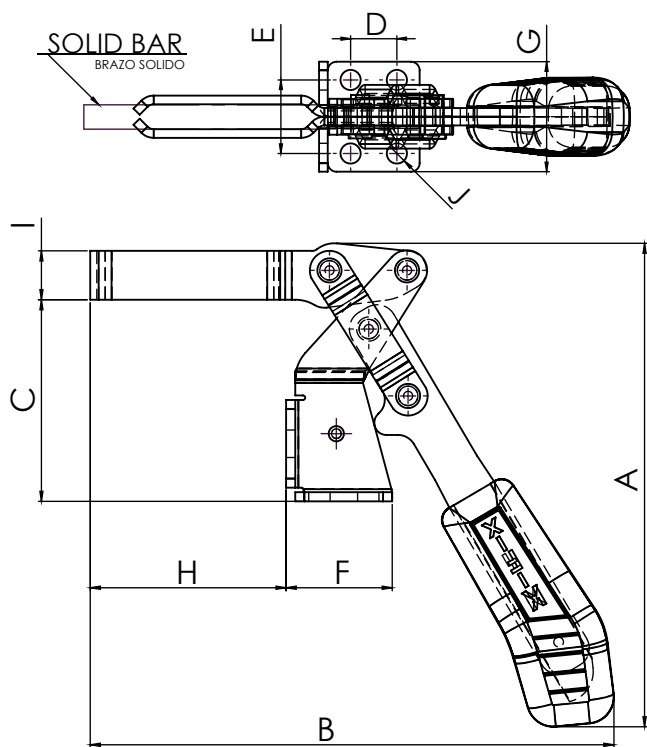
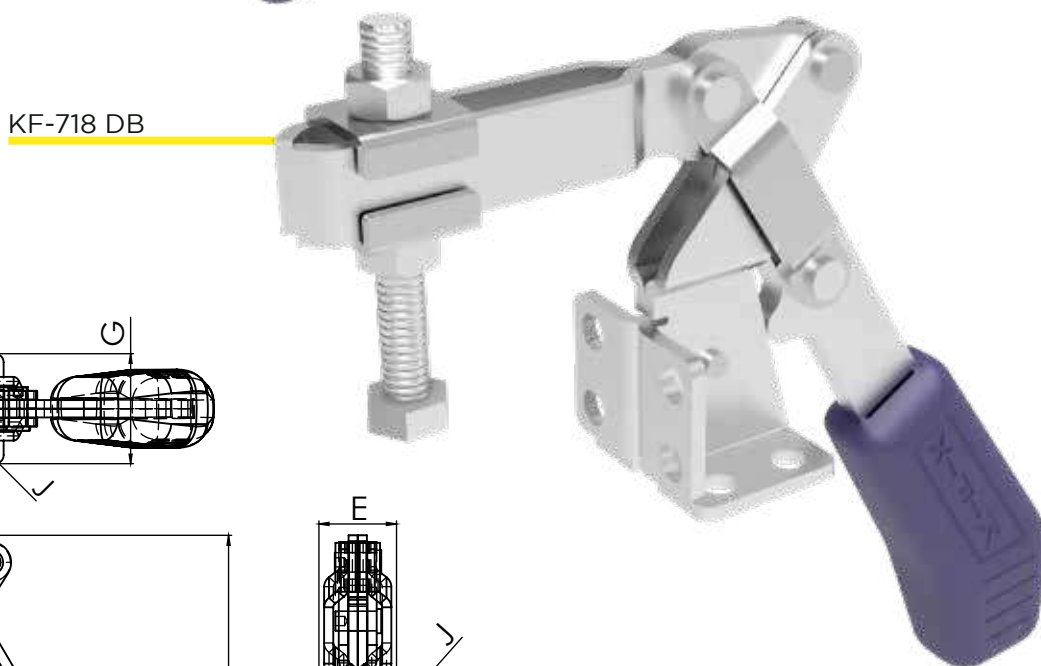
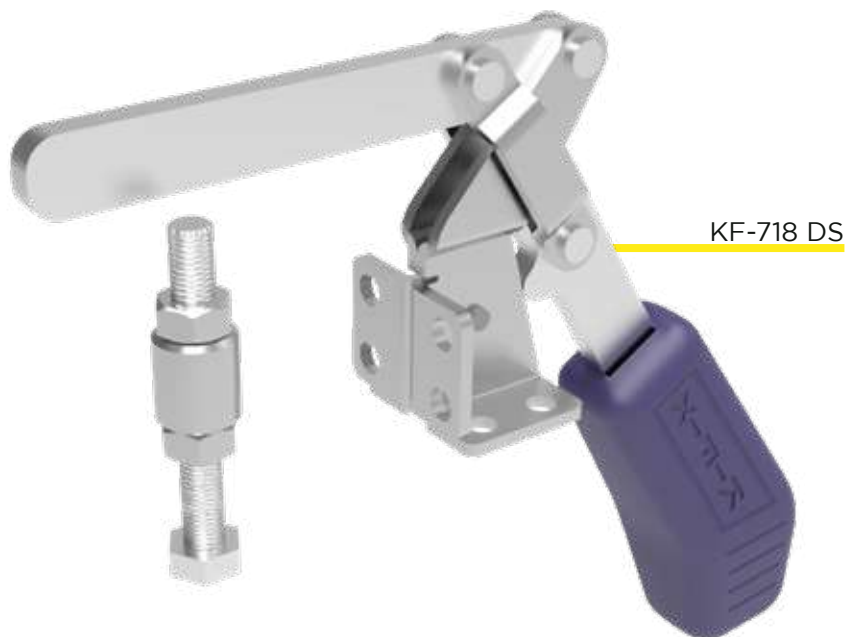

- BASES**  
D - Flanged Base  
R - Straight Base
- HASTES**  
B - U-Bar  
S - Solid Bar
- PIES**  
D - Doblado  
R - Recto
- BRAZO**  
B - EN "U"  
S - Solido

REFERENCE	RETENTION FORCE KGf (LBF)	A (IN)	B (IN)	C (IN)	D (IN)	E (IN)	F (IN)	G (IN)	H (IN)	I (IN)	J (IN)	SPINDLE	OPENING ANGLE	WEIGHT KG (LB)
Referencia	Fuerza Retención Kgf (lbf)											Tornillo	Angulo de Apertura	Peso
KF-718 DB	170 (374)	158,3 (6,23)	171,5 (6,75)	66 (2,60)	16 (0,63)	25,4 (1,00)	35 (1,38)	38 (1,50)	64 (2,52)	16 (0,63)	7,0 (0,28)	M8	185	0,500 (1,100)
KF-718 DS	170 (374)	170,6 (6,72)	198,3 (7,81)	66 (2,60)	16 (0,63)	25,4 (1,00)	35 (1,38)	38 (1,50)	82 (3,23)	16 (0,63)	7,0 (0,28)	M8	185	0,520 (1,144)

# VERTICAL HOLD-DOWN TOGGLE CLAMP PRENSA RÁPIDA VERTICAL

KF-016 RS



KF-018 DB TR



KF-10 DB



KF-017 DBL



KF-111 RBL



KF-18 DS

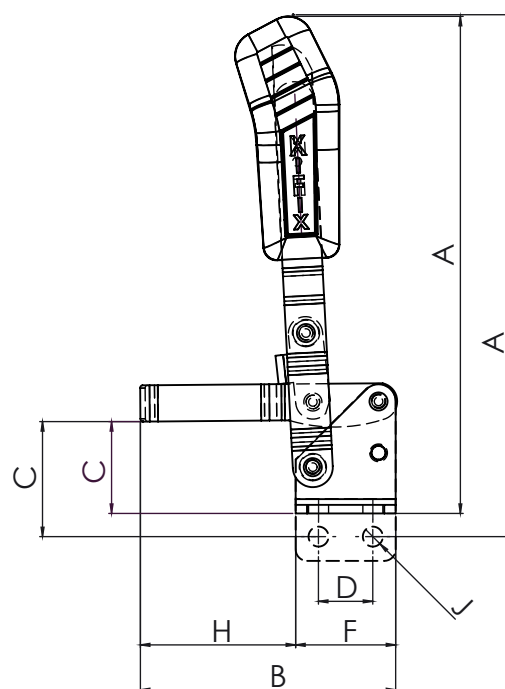
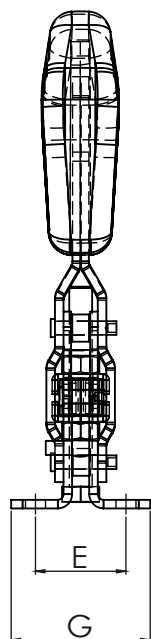
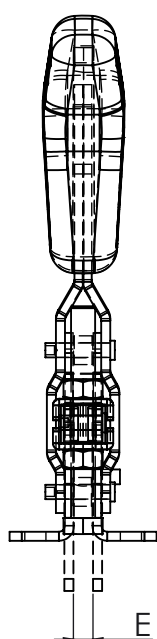
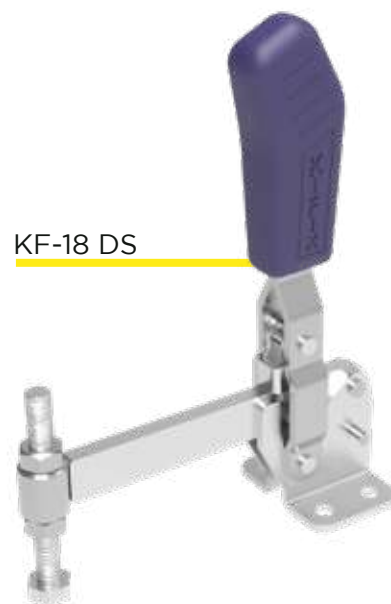



# VERTICAL HOLD-DOWN TOGGLE CLAMP PRENSA RÁPIDA VERTICAL



**KF-011 DB TR**



**KF-012 RB**



**KF-111DBL**

**BASES**  
D - Flanged Base  
R - Straight Base

**BAR**  
B - U-Bar  
S - Solid Bar  
L - Long U-Bar

TR - with  
Toggle -  
Lock Plus

**PIES**  
D - Doblado  
R - Recto

**BRAZO**  
B - EN "U"  
S - Solido  
L - Largo

TR - Bloqueo

REFERENCE	RETENTION FORCE KGf (LBF)	A (IN)	B (IN)	C (IN)	D (IN)	E (IN)	F (IN)	G (IN)	H (IN)	J (IN)	SPINDLE	OPENING ANGLE	WEIGHT KG (LB)
Referencia	Fuerza Retención Kgf (lbf)										Tornillo	Angulo de Apertura	Peso
KF-010 DB	32 (70.4)	86 (3.39)	51.3 (2.02)	16 (0.63)	16 (0.63)	23.9 (0.94)	25.4 (1.00)	33.3 (1.31)	25.9 (1.02)	4.3 (0.17)	M6	90	0.090 (0.190)
KF-010 RB	32 (70)	93 (3.66)	51.3 (2.02)	23 (0.91)	16 (0.63)	4 (0.16)	25.4 (1.00)	-	25.9 (1.02)	4.3 (0.17)	M6	90	0.090 (0.190)
KF-012 DB	90 (198)	128 (5.04)	70 (2.76)	23 (0.91)	12.7 (0.50)	27 (1.06)	25 (0.98)	39.6 (1.56)	45 (1.77)	5.6 (0.22)	M6	90	0.210 (0.462)
KF-012 DBL	70 (154)	128 (5.04)	85 (3.35)	23 (0.91)	12.7 (0.50)	27 (1.06)	25 (0.98)	39.6 (1.56)	60 (2.36)	5.6 (0.22)	M6	90	0.215 (0.473)
KF-012 RB	90 (198)	132 (5.20)	70 (2.76)	29 (1.14)	12.7 (0.50)	6 (0.24)	25 (0.98)	-	45 (1.77)	5.6 (0.22)	M6	90	0.210 (0.462)
KF-012 RBL	70 (154)	132 (5.20)	85 (3.35)	29 (1.14)	12.7 (0.50)	6 (0.24)	25 (0.98)	-	60 (2.36)	5.6 (0.22)	M6	90	0.215 (0.473)
KF-017 DB	170 (374)	175 (6.89)	90 (3.54)	32 (1.26)	19 (0.75)	32 (1.26)	35 (1.38)	49 (1.93)	55 (2.17)	7.0 (0.28)	M8	90	0.400 (0.880)
KF-017 RB TR	170 (374)	183 (7.20)	90 (3.54)	40 (1.57)	19 (0.75)	6.5 (0.26)	35 (1.38)	-	55 (2.17)	7.0 (0.28)	M8	90	0.400 (0.880)
KF-017 DB TR	170 (374)	175 (6.89)	90 (3.54)	32 (1.26)	19 (0.75)	32 (1.26)	35 (1.38)	49 (1.93)	55 (2.17)	7.0 (0.28)	M8	90	0.400 (0.880)
KF-017 DBL	150 (330)	175 (6.89)	120 (4.72)	32 (1.26)	19 (0.75)	32 (1.26)	35 (1.38)	49 (1.93)	85 (3.35)	7.0 (0.28)	M8	90	0.410 (0.902)
KF-017 DBL TR	150 (330)	175 (6.89)	120 (4.72)	32 (1.26)	19 (0.75)	32 (1.26)	35 (1.38)	49 (1.93)	85 (3.35)	7.0 (0.28)	M8	90	0.410 (0.902)
KF-017 DS	200 (440)	175 (6.89)	120 (4.72)	32 (1.26)	19 (0.75)	32 (1.26)	35 (1.38)	49 (1.93)	85 (3.35)	7.0 (0.28)	M8	90	0.410 (0.902)
KF-017 RB	170 (374)	183 (7.20)	90 (3.54)	40 (1.57)	19 (0.75)	6.5 (0.26)	35 (1.38)	-	55 (2.17)	7.0 (0.28)	M8	90	0.400 (0.880)
KF-017 RBL	150 (330)	183 (7.20)	120 (4.72)	40 (1.57)	19 (0.75)	6.5 (0.26)	35 (1.38)	-	85 (3.35)	7.0 (0.28)	M8	90	0.410 (0.902)
KF-017 RS	200 (440)	183 (7.20)	120 (4.72)	40 (1.57)	19 (0.75)	6.5 (0.26)	35 (1.38)	-	85 (3.35)	7.0 (0.28)	M8	90	0.410 (0.902)
KF-018 DB	250 (550)	178 (7.01)	120 (4.72)	32 (1.26)	20 (0.79)	33.5 (1.32)	37 (1.46)	50.5 (1.99)	83 (3.27)	7.0 (0.28)	M8	90	0.430 (0.946)
KF-018 DB TR	250 (550)	178 (7.01)	120 (4.72)	32 (1.26)	20 (0.79)	33.5 (1.32)	37 (1.46)	50.5 (1.99)	83 (3.27)	7.0 (0.28)	M8	90	0.430 (0.946)
KF-018 DS	250 (550)	178 (7.01)	120 (4.72)	32 (1.26)	20 (0.79)	33.5 (1.32)	37 (1.46)	50.5 (1.99)	83 (3.27)	7.0 (0.28)	M8	90	0.430 (0.946)
KF-018 RB	250 (550)	186 (7.32)	120 (4.72)	40 (1.57)	20 (0.79)	6.5 (0.26)	37 (1.46)	-	83 (3.27)	7.0 (0.28)	M8	90	0.430 (0.946)
KF-018 RS	250 (550)	186 (7.32)	120 (4.72)	40 (1.57)	20 (0.79)	6.5 (0.26)	37 (1.46)	-	83 (3.27)	7.0 (0.28)	M8	90	0.430 (0.946)
KF-016 DB	280 (616)	175 (6.89)	90 (3.54)	31.5 (1.24)	19.5 (0.77)	32.5 (1.28)	35 (1.38)	50 (1.97)	55 (2.17)	7.5 (0.30)	M8	90	0.420 (0.924)
KF-016 DBL	260 (572)	175 (6.89)	137.4 (5.41)	31.5 (1.24)	19.5 (0.77)	32.5 (1.28)	35 (1.38)	50 (1.97)	102.4 (4.03)	7.5 (0.30)	M8	90	0.440 (0.968)
KF-016 DS	310 (682)	175 (6.89)	137.4 (5.41)	31.5 (1.24)	19.5 (0.77)	32.5 (1.28)	35 (1.38)	50 (1.97)	102.4 (4.03)	7.5 (0.30)	M8	90	0.440 (0.968)
KF-016 RB	280 (616)	183 (7.20)	90 (3.54)	39 (1.54)	19.5 (0.77)	6.7 (0.26)	35 (1.38)	-	55 (2.17)	7.5 (0.30)	M8	90	0.420 (0.924)
KF-016 RBL	260 (572)	183 (7.20)	137.4 (5.41)	39 (1.54)	19.5 (0.77)	6.7 (0.26)	35 (1.38)	-	102.4 (4.03)	7.5 (0.30)	M8	90	0.440 (0.968)
KF-016 RS	310 (682)	183 (7.20)	137.4 (5.41)	39 (1.54)	19.5 (0.77)	6.7 (0.26)	35 (1.38)	-	102.4 (4.03)	7.5 (0.30)	M8	90	0.440 (0.968)
KF-011 DB	340 (749)	211 (8.31)	140 (5.51)	41 (1.61)	32 (1.26)	44 (1.73)	48 (1.89)	60 (2.36)	92 (3.62)	8.5 (0.33)	M10	90	0.820 (1.804)
KF-011 DB TR	340 (749)	211 (8.31)	140 (5.51)	41 (1.61)	32 (1.26)	44 (1.73)	48 (1.89)	60 (2.36)	92 (3.62)	8.5 (0.33)	M10	90	0.820 (1.804)
KF-011 DBL	315 (694)	211 (8.31)	166 (6.54)	41 (1.61)	32 (1.26)	44 (1.73)	48 (1.89)	60 (2.36)	118 (4.65)	8.5 (0.33)	M10	90	0.850 (1.870)
KF-011 DBL TR	360 (793)	211 (8.31)	166 (6.54)	41 (1.61)	32 (1.26)	44 (1.73)	48 (1.89)	60 (2.36)	118 (4.65)	8.5 (0.33)	M10	90	0.850 (1.870)
KF-011 DS	340 (749)	211 (8.31)	166 (6.54)	41 (1.61)	32 (1.26)	44 (1.73)	48 (1.89)	60 (2.36)	118 (4.65)	8.5 (0.33)	M10	90	0.830 (1.826)
KF-011 RB	340 (749)	223 (8.78)	140 (5.51)	53 (2.09)	32 (1.26)	8 (0.31)	48 (1.89)	-	92 (3.62)	8.5 (0.33)	M10	90	0.820 (1.804)
KF-011 RBL	315 (694)	223 (8.78)	166 (6.54)	53 (2.09)	32 (1.26)	8 (0.31)	48 (1.89)	-	118 (4.65)	8.5 (0.33)	M10	90	0.850 (1.870)
KF-011 RS	360 (793)	223 (8.78)	166 (6.54)	53 (2.09)	32 (1.26)	8 (0.31)	48 (1.89)	-	118 (4.65)	8.5 (0.33)	M10	90	0.830 (1.826)
KF-111 DB	680 (1496)	258 (10.16)	155 (6.10)	50 (1.97)	32 (1.26)	45 (1.77)	55 (2.17)	67 (2.64)	100 (3.94)	8.5 (0.33)	M10	90	1.400 (3.080)
KF-111 DB TR	680 (1496)	258 (10.16)	155 (6.10)	50 (1.97)	32 (1.26)	45 (1.77)	55 (2.17)	67 (2.64)	100 (3.94)	8.5 (0.33)	M10	90	1.400 (3.080)
KF-111 DBL	650 (1430)	258 (10.16)	200 (7.87)	50 (1.97)	32 (1.26)	45 (1.77)	55 (2.17)	67 (2.64)	145 (5.71)	8.5 (0.33)	M10	90	1.440 (3.168)
KF-111 DBL TR	650 (1430)	258 (10.16)	200 (7.87)	50 (1.97)	32 (1.26)	45 (1.77)	55 (2.17)	67 (2.64)	145 (5.71)	8.5 (0.33)	M10	90	1.440 (3.168)
KF-111 DS	700 (1540)	258 (10.16)	200 (7.87)	50 (1.97)	32 (1.26)	45 (1.77)	55 (2.17)	67 (2.64)	145 (5.71)	8.5 (0.33)	M10	90	1.420 (3.124)
KF-111 RB	680 (1496)	268 (10.55)	155 (6.10)	60 (2.36)	32 (1.26)	9.5 (0.37)	55 (2.17)	-	100 (3.94)	8.5 (0.33)	M10	90	1.400 (3.080)
KF-111 RBL	650 (1430)	268 (10.55)	200 (7.87)	60 (2.36)	32 (1.26)	9.5 (0.37)	55 (2.17)	-	145 (5.71)	8.5 (0.33)	M10	90	1.440 (3.168)
KF-111 RS	700 (1540)	268 (10.55)	200 (7.87)	60 (2.36)	32 (1.26)	9.5 (0.37)	55 (2.17)	-	145 (5.71)	8.5 (0.33)	M10	90	1.420 (3.124)

# VERTICAL HOLD-DOWN TOGGLE CLAMP PRENSA RÁPIDA VERTICAL



**KF-631 DI TR**

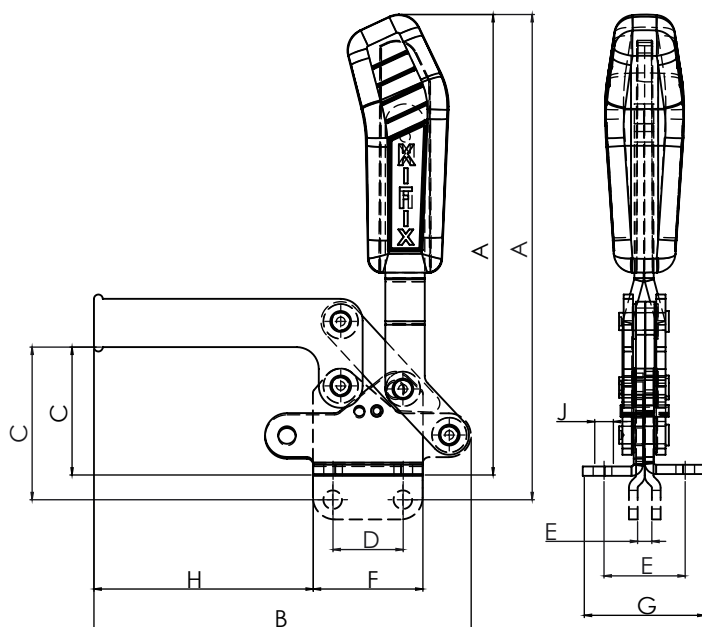

**KF-631 DIL**



**KF-631 RL**

**BASES**

D - Dobrada  
R - Reta

**HASTES**

B - Bifurcada  
S - Sólida  
L - Longa  
I - Invertida

TR - Trava

**BASES**

D - Flanged base  
R - Straight Base

**BAR**

S - Solid Bar  
L - Long U-Bar

**CABLE**  
T - Cable "T"

REFERENCE	RETENTION FORCE KGF (LBF)	A (IN)	B (IN)	C (IN)	D (IN)	E (IN)	F (IN)	G (IN)	H (IN)	J (IN)	SPINDLE	OPENING ANGLE	WEIGHT KG (LB)
Referencia	Fuerza Retención Kgf (lbf)										Tornillo	Angulo de Apertura	Peso
KF-631 D	400 (880)	189 (7,44)	129 (5,08)	28 (1,10)	32 (1,26)	37 (1,46)	50 (1,97)	55 (2,17)	57 (2,24)	8,5 (0,33)	M10	85	0,92
KF-631 D TR	400 (880)	204 (8,03)	129 (5,08)	28 (1,10)	32 (1,26)	37 (1,46)	50 (1,97)	55 (2,17)	57 (2,24)	8,5 (0,33)	M10	85	1,05
KF-631 DI	400 (880)	189 (7,44)	129 (5,08)	56 (2,20)	32 (1,26)	37 (1,46)	50 (1,97)	55 (2,17)	57 (2,24)	8,5 (0,33)	M10	85	0,92
KF-631 DI TR	400 (880)	204 (8,03)	129 (5,08)	56 (2,20)	32 (1,26)	37 (1,46)	50 (1,97)	55 (2,17)	57 (2,24)	8,5 (0,33)	M10	85	1,05
KF-631 R	400 (880)	201 (7,91)	129 (5,08)	40 (1,57)	32 (1,26)	6,5 (0,26)	50 (1,97)	-	57 (2,24)	8,5 (0,33)	M10	85	0,92
KF-631 R TR	400 (880)	216 (8,50)	129 (5,08)	40 (1,57)	32 (1,26)	6,5 (0,26)	50 (1,97)	-	57 (2,24)	8,5 (0,33)	M10	85	1,05
KF-631 RI	400 (880)	201 (7,91)	129 (5,08)	68 (2,68)	32 (1,26)	6,5 (0,26)	50 (1,97)	-	57 (2,24)	8,5 (0,33)	M10	85	0,92
KF-631 RI TR	400 (880)	216 (8,50)	129 (5,08)	68 (2,68)	32 (1,26)	6,5 (0,26)	50 (1,97)	-	57 (2,24)	8,5 (0,33)	M10	85	1,05
KF-631 DL	300 (660)	189 (7,44)	172 (6,77)	28 (1,10)	32 (1,26)	37 (1,46)	50 (1,97)	55 (2,17)	100 (3,94)	8,5 (0,33)	M10	85	0,98
KF-631 DL TR	300 (660)	204 (8,03)	172 (6,77)	28 (1,10)	32 (1,26)	37 (1,46)	50 (1,97)	55 (2,17)	100 (3,94)	8,5 (0,33)	M10	85	1,11
KF-631 DIL	300 (660)	189 (7,44)	172 (6,77)	56 (2,20)	32 (1,26)	37 (1,46)	50 (1,97)	55 (2,17)	100 (3,94)	8,5 (0,33)	M10	85	0,98
KF-631 DIL TR	300 (660)	204 (8,03)	172 (6,77)	56 (2,20)	32 (1,26)	37 (1,46)	50 (1,97)	55 (2,17)	100 (3,94)	8,5 (0,33)	M10	85	1,11
KF-631 RL	300 (660)	201 (7,91)	172 (6,77)	40 (1,57)	32 (1,26)	6,5 (0,26)	50 (1,97)	-	100 (3,94)	8,5 (0,33)	M10	85	0,98
KF-631 RL TR	300 (660)	216 (8,50)	172 (6,77)	40 (1,57)	32 (1,26)	6,5 (0,26)	50 (1,97)	-	100 (3,94)	8,5 (0,33)	M10	85	1,11
KF-631 RIL	300 (660)	201 (7,91)	172 (6,77)	68 (2,68)	32 (1,26)	6,5 (0,26)	50 (1,97)	-	100 (3,94)	8,5 (0,33)	M10	85	0,98
KF-631 RIL TR	300 (660)	216 (8,50)	172 (6,77)	68 (2,68)	32 (1,26)	6,5 (0,26)	50 (1,97)	-	100 (3,94)	8,5 (0,33)	M10	85	1,11

# VERTICAL HOLD-DOWN TOGGLE CLAMP PRENSA RÁPIDA VERTICAL



KF-017 DT



KF-017 DTS



KF-017 RTL

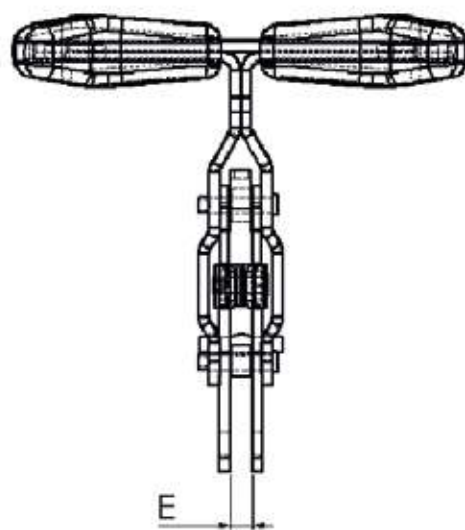
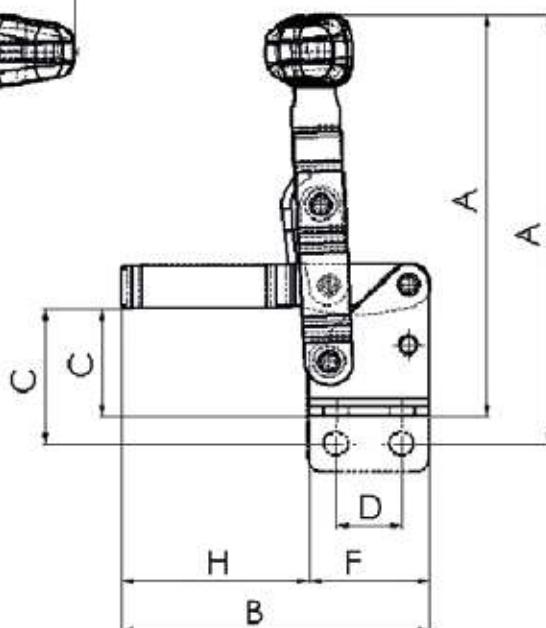
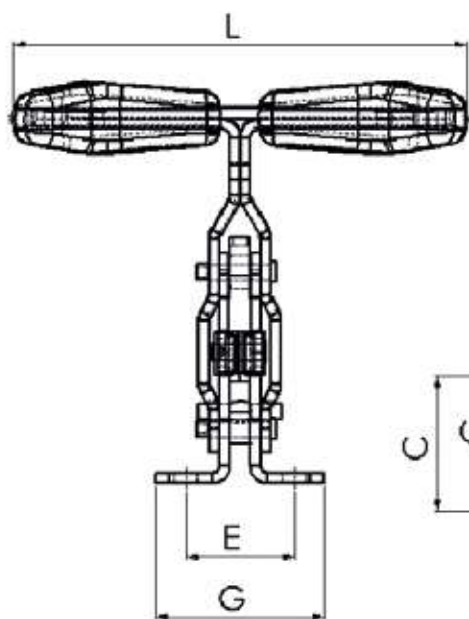

**BASES**  
D - Flanged base  
R - Straight Base

**BAR**  
S - Solid Bar  
L - Long U-Bar

**CABLE**  
T- Cable "T"

**PIES**  
D - Doblado  
R - Recto

**BRAZO**  
S - Solido  
L - Largo

**CABLE**  
T- Cable "T"

REFERENCE	RETENTION FORCE KGf (LBF)	A (IN)	B (IN)	C (IN)	D (IN)	E (IN)	F (IN)	G (IN)	H (IN)	J (IN)	L (IN)	SPINDLE	OPENING ANGLE	WEIGHT KG (LB)
Referencia	Fuerza Retención Kgf (lbf)											Tornillo	Angulo de Apertura	Peso
KF-017 DT	170 (374)	120 (4,72)	90 (3,54)	32 (1,26)	19 (0,75)	32 (1,26)	35 (1,38)	49 (1,93)	55 (2,17)	7,0 (0,28)	132 (5,20)	M8	100	0,415 (0,913)
KF-017 DTL	150 (330)	120 (4,72)	120 (4,72)	32 (1,26)	19 (0,75)	32 (1,26)	35 (1,38)	49 (1,93)	85 (3,35)	7,0 (0,28)	132 (5,20)	M8	100	0,415 (0,913)
KF-017 DTS	200 (440)	120 (4,72)	120 (4,72)	32 (1,26)	19 (0,75)	32 (1,26)	35 (1,38)	49 (1,93)	85 (3,35)	7,0 (0,28)	132 (5,20)	M8	100	0,415 (0,913)
KF-017 RT	170 (374)	128 (5,04)	90 (3,54)	40 (1,57)	19 (0,75)	6,5 (0,26)	35 (1,38)	-	55 (2,17)	7,0 (0,28)	132 (5,20)	M8	100	0,415 (0,913)
KF-017 RTL	150 (330)	128 (5,04)	120 (4,72)	40 (1,57)	19 (0,75)	6,5 (0,26)	35 (1,38)	-	85 (3,35)	7,0 (0,28)	132 (5,20)	M8	100	0,415 (0,913)
KF-017 RTS	200 (440)	128 (5,04)	120 (4,72)	40 (1,57)	19 (0,75)	6,5 (0,26)	35 (1,38)	-	85 (3,35)	7,0 (0,28)	132 (5,20)	M8	100	0,415 (0,913)

# VERTICAL HOLD-DOWN TOGGLE CLAMP PRENSA RÁPIDA VERTICAL



KF-010 F

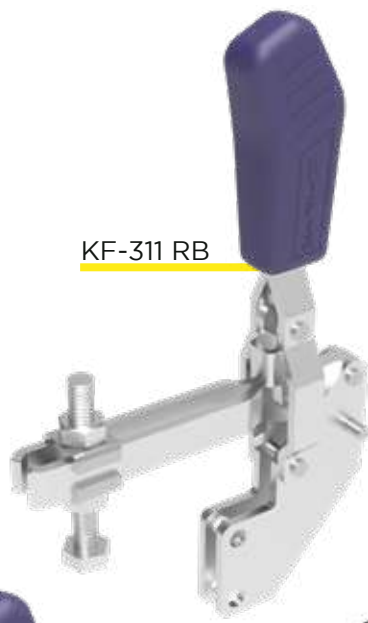

KF-311 RB



KF-211 DS



KF-411 RS

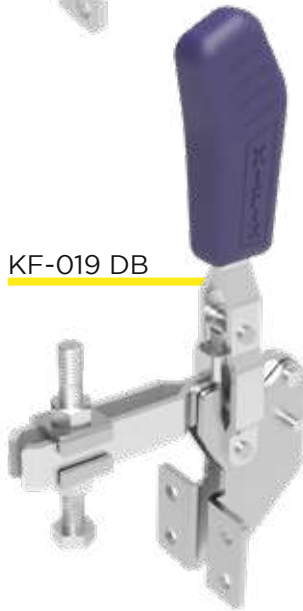

KF-019 DB

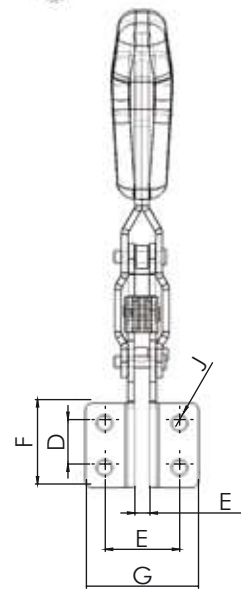
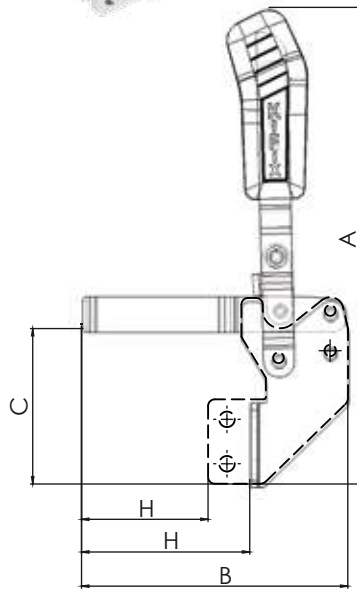

**BASES**  
D - Flanged Base  
R - Straight Base

**HASTES**  
B - U-Bar  
S - Solid Bar  
L - Long U-Bar

**PIES**  
D - Doblado  
R - Recto

**BRAZO**  
B - EN "U"  
S - Solido  
L - Largo

REFERENCE	RETENTION FORCE KGf (LBF)	A	B	C	D	E	F	G	H	J	SPINDLE	OPENING ANGLE	WEIGHT KG (LB)
Referencia	Fuerza Retención Kgf (lbf)										Tornillo	Angulo de Apertura	Peso
KF-010 F	32 (70)	112 (4.41)	51 (2.01)	42 (1.65)	16 (0.63)	23,7 (0.93)	25 (0.98)	33 (1.30)	24 (0.94)	4,3 (0.17)	M6	100	0,100 (0.220)
KF-012 F	90 (198)	149 (5.87)	70 (2.76)	47 (1.85)	12,7 (0.50)	27 (1.06)	25 (0.98)	40 (1.57)	41 (1.61)	5,5 (0.22)	M6	100	0,230 (0.506)
KF-019 DB	250 (550)	215 (8.46)	120 (4.72)	70 (2.76)	20 (0.79)	33,5 (1.32)	38 (1.50)	50,5 (1.99)	76 (2.99)	7,0 (0.28)	M8	100	0,500 (1.100)
KF-019 DS	250 (550)	215 (8.46)	120 (4.72)	70 (2.76)	20 (0.79)	33,5 (1.32)	38 (1.50)	50,5 (1.99)	76 (2.99)	7,0 (0.28)	M8	100	0,500 (1.100)
KF-019 RB	250 (550)	215 (8.46)	120 (4.72)	70 (2.76)	20 (0.79)	6,5 (0.26)	38 (1.50)	-	57 (2.24)	7,0 (0.28)	M8	100	0,500 (1.100)
KF-019 RS	250 (550)	215 (8.46)	120 (4.72)	70 (2.76)	20 (0.79)	6,5 (0.26)	38 (1.50)	-	57 (2.24)	7,0 (0.28)	M8	100	0,500 (1.100)
KF-211 DB	150 (330)	207 (8.15)	120 (4.72)	65 (2.56)	19 (0.75)	32 (1.26)	35 (1.38)	46,5 (1.83)	79 (3.11)	7,0 (0.28)	M8	100	0,480 (1.056)
KF-211 DS	200 (440)	207 (8.15)	120 (4.72)	65 (2.56)	19 (0.75)	32 (1.26)	35 (1.38)	46,5 (1.83)	79 (3.11)	7,0 (0.28)	M8	100	0,480 (1.056)
KF-211 RB	150 (330)	207 (8.15)	120 (4.72)	65 (2.56)	19 (0.75)	6,5 (0.26)	35 (1.38)	-	69 (2.72)	7,0 (0.28)	M8	100	0,480 (1.056)
KF-211 RS	200 (440)	207 (8.15)	120 (4.72)	65 (2.56)	19 (0.75)	6,5 (0.26)	35 (1.38)	-	69 (2.72)	7,0 (0.28)	M8	100	0,480 (1.056)
KF-311 DB	250 (550)	260 (10.24)	166 (6.54)	90 (3.54)	32 (1.26)	44 (1.73)	49 (1.93)	60 (2.36)	106 (4.17)	8,5 (0.33)	M10	100	0,960 (2.112)
KF-311 DS	300 (660)	260 (10.24)	166 (6.54)	90 (3.54)	32 (1.26)	44 (1.73)	49 (1.93)	60 (2.36)	106 (4.17)	8,5 (0.33)	M10	100	0,930 (2.046)
KF-311 RB	250 (550)	260 (10.24)	166 (6.54)	90 (3.54)	32 (1.26)	8 (0.31)	49 (1.93)	-	97 (3.82)	8,5 (0.33)	M10	100	0,960 (2.112)
KF-311 RB	250 (550)	260 (10.24)	166 (6.54)	90 (3.54)	32 (1.26)	8 (0.31)	49 (1.93)	-	97 (3.82)	8,5 (0.33)	M10	100	0,960 (2.112)
KF-411 DB	650 (1430)	321 (12.64)	200 (7.87)	113 (4.45)	32 (1.26)	45 (1.77)	55 (2.17)	67 (2.64)	134 (5.28)	8,5 (0.33)	M10	100	1,750 (3.850)
KF-411 DS	700 (1540)	321 (12.64)	200 (7.87)	113 (4.45)	32 (1.26)	45 (1.77)	55 (2.17)	67 (2.64)	134 (5.28)	8,5 (0.33)	M10	100	1,700 (3.740)
KF-411 RB	650 (1430)	321 (12.64)	200 (7.87)	113 (4.45)	32 (1.26)	10 (0.39)	55 (2.17)	-	126 (4.96)	8,5 (0.33)	M10	100	1,750 (3.850)
KF-411 RS	700 (1540)	321 (12.64)	200 (7.87)	113 (4.45)	32 (1.26)	10 (0.39)	55 (2.17)	-	126 (4.96)	8,5 (0.33)	M10	100	1,700 (3.740)

# VERTICAL HOLD-DOWN TOGGLE CLAMP PRENSA RÁPIDA VERTICAL



**KF-615 B**



**KF-641 DS**

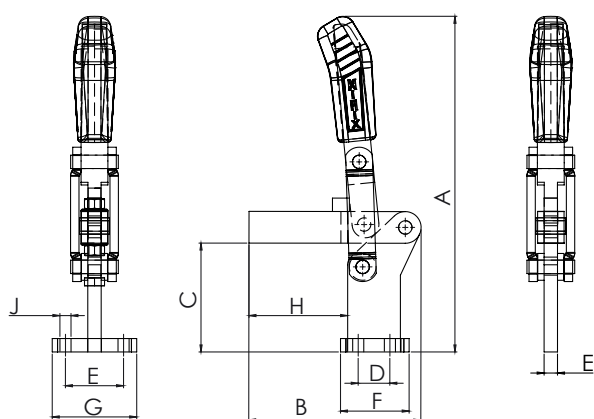
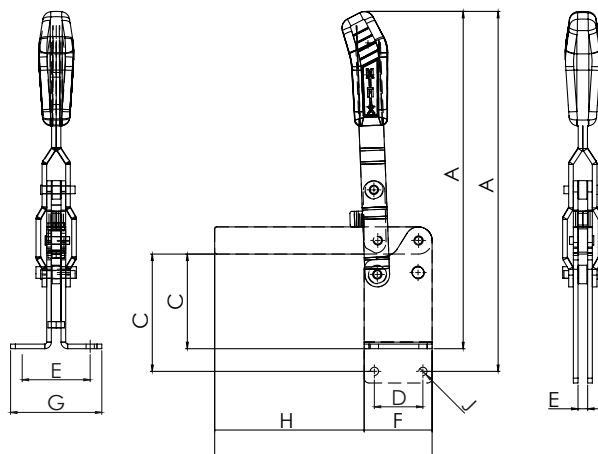

**KF-066 STR**



**KF-066 TS**



**KF-875**

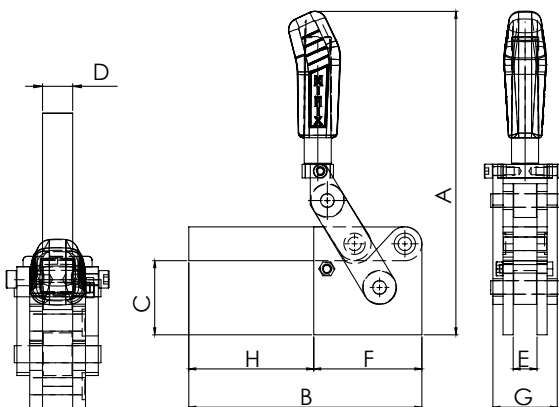

**BASES**  
D - Flanged Base  
R - Straight Base

**BAR**  
B - U-Bar  
S - Solid Bar  
L - Long U-Bar

**TR -**  
with  
Toggle-  
Lock Plus

**PIES**  
D - Doblado  
R - Reta  
T - Pies T

**BRAZO**  
B - EM "U"  
S - Solido  
L - Largo

**TR -**  
Bloqueo

REFERENCE	RETENTION FORCE KGf (LBF)	A (IN)	B (IN)	C (IN)	D (IN)	E (IN)	F (IN)	G (IN)	H (IN)	J (IN)	SPINDLE	OPENING ANGLE	WEIGHT KG (LB)
Referencia	Fuerza Retención Kg (Lbf)										Tornillo	Angulo de Apertura	Peso
KF-615 B	340 (748)	215 (8,46)	108 (4,25)	42 (1,65)	25,4 (1,00)	38,1 (1,50)	50,8 (2,00)	50,8 (2,00)	57 (2,24)	7,0 (0,28)	M8	125	0,920 (2,024)
KF-615 BL	340 (748)	215 (8,46)	191 (7,52)	42 (1,65)	25,4 (1,00)	38,1 (1,50)	50,8 (2,00)	50,8 (2,00)	140 (5,51)	7,0 (0,28)	M8	125	0,920 (2,024)
KF-616 D	950 (2090)	249 (9,80)	155 (6,10)	50 (1,97)	32 (1,26)	45 (1,77)	53,5 (2,11)	67 (2,64)	101,5 (4,00)	7,0 (0,28)	M10	125	1,350 (2,970)
KF-616 R	950 (2090)	257 (10,12)	155 (6,10)	58 (2,28)	32 (1,26)	9,5 (0,37)	53,5 (2,11)	-	101,5 (4,00)	7,0 (0,28)	M10	125	1,350 (2,970)
KF-641 DB	800 (1760)	347 (13,66)	224 (8,82)	98 (3,86)	50 (1,97)	70 (2,76)	70 (2,76)	94 (3,70)	154 (6,06)	8,5 (0,33)	M10	85	2,250 (4,950)
KF-641 RB	800 (1760)	371 (14,61)	224 (8,82)	121 (4,76)	50 (1,97)	10 (0,39)	70 (2,76)	-	154 (6,06)	8,5 (0,33)	M10	85	2,250 (4,950)
KF-641 DS	800 (1760)	347 (13,66)	224 (8,82)	98 (3,86)	50 (1,97)	70 (2,76)	70 (2,76)	94 (3,70)	154 (6,06)	8,5 (0,33)	M10	85	2,250 (4,950)
KF-641 RS	800 (1760)	371 (14,61)	224 (8,82)	121 (4,76)	50 (1,97)	10 (0,39)	70 (2,76)	-	154 (6,06)	8,5 (0,33)	M10	85	2,250 (4,950)
KF-066 S	1400 (3080)	305 (12,01)	163 (6,42)	90 (3,54)	-	12,7 (0,50)	50 (1,97)	-	93 (3,66)	-	M12	150	3,300 (7,260)
KF-066 STR	1400 (3080)	305 (12,01)	163 (6,42)	90 (3,54)	-	12,7 (0,50)	50 (1,97)	-	93 (3,66)	-	M12	150	3,800 (8,360)
KF-066 TS	1400 (3080)	318 (12,52)	163 (6,42)	103 (4,06)	30 (1,18)	55 (2,17)	65 (2,56)	80 (3,15)	93 (3,66)	10,5 (0,41)	M12	150	3,800 (8,360)
KF-066 TSTR	1400 (3080)	318 (12,52)	163 (6,42)	103 (4,06)	30 (1,18)	55 (2,17)	65 (2,56)	80 (3,15)	93 (3,66)	10,5 (0,41)	M12	150	4,300 (9,460)
KF-845	1150 (2530)	246 (9,69)	190 (7,48)	56,2 (2,21)	19 (0,75)	19 (0,75)	82 (3,23)	50,9 (2,00)	108 (4,25)	-	M12	120	3,350 (7,370)
KF-875	1800 (3960)	304 (11,97)	219 (8,62)	69,7 (2,74)	22,4 (0,88)	22,4 (0,88)	101,6 (4,00)	60,5 (2,38)	117,4 (4,62)	-	M12	90	5,600 (12,320)



# VERTICAL HOLD-DOWN TOGGLE CLAMP PRENSA RÁPIDA VERTICAL

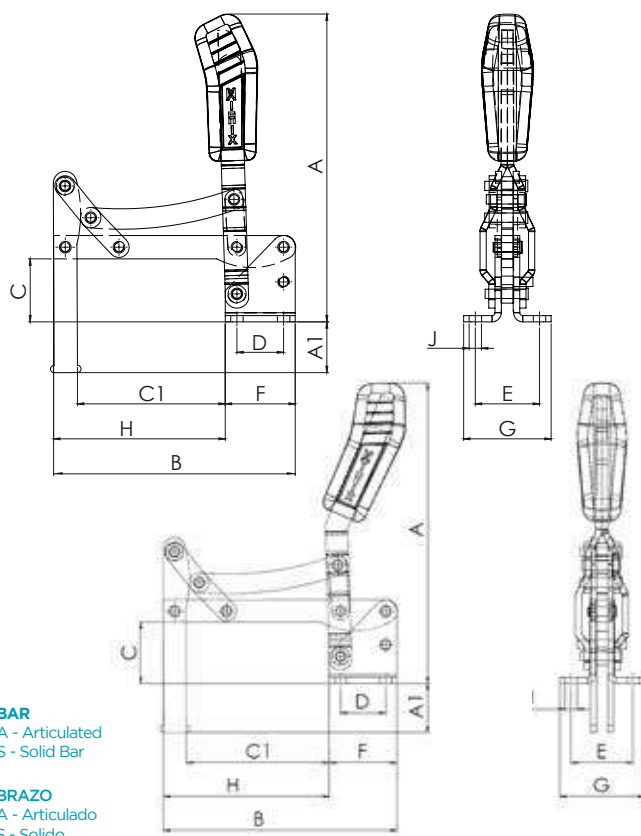

REFERENCE Referencia	RETENTION FORCE KGf (LBF) Fuerza Retención Kgf (lbf)	A (IN)	A1 (IN)	B (IN)	C (IN)	C1 (IN)	D (IN)	E (IN)	F (IN)	G (IN)	H (IN)	J (IN)	SPINDLE Tornillo	OPENING ANGLE Angulo de Apertura	WEIGHT KG (LB) Peso
KF-017 DS A	160 (352)	175 (6,89)	29 (1,14)	120 (4,72)	32 (1,26)	73 (2,87)	19 (0,75)	32 (1,26)	35 (1,38)	49 (1,93)	85 (3,35)	7,0 (0,28)	M6	90	0,530 (1,166)
KF-011 DS A	240 (528)	211 (8,31)	35 (1,38)	166 (6,54)	41 (1,61)	101 (3,98)	32 (1,26)	44 (1,73)	48 (1,89)	60 (2,36)	118 (4,65)	8,5 (0,33)	M8	90	1,150 (2,530)
KF-011 DS A JD	240 (528)	211 (8,31)	35 (1,38)	166 (6,54)	41 (1,61)	101 (3,98)	32 (1,26)	44 (1,73)	48 (1,89)	60 (2,36)	118 (4,65)	8,5 (0,33)	M8	90	1,150 (2,530)
KF-111 DS A	560 (1232)	258 (10,16)	43 (1,69)	200 (7,87)	50 (1,97)	125 (4,92)	32 (1,26)	45 (1,77)	55 (2,17)	67 (2,64)	145 (5,71)	8,5 (0,33)	M10	90	2,050 (4,510)

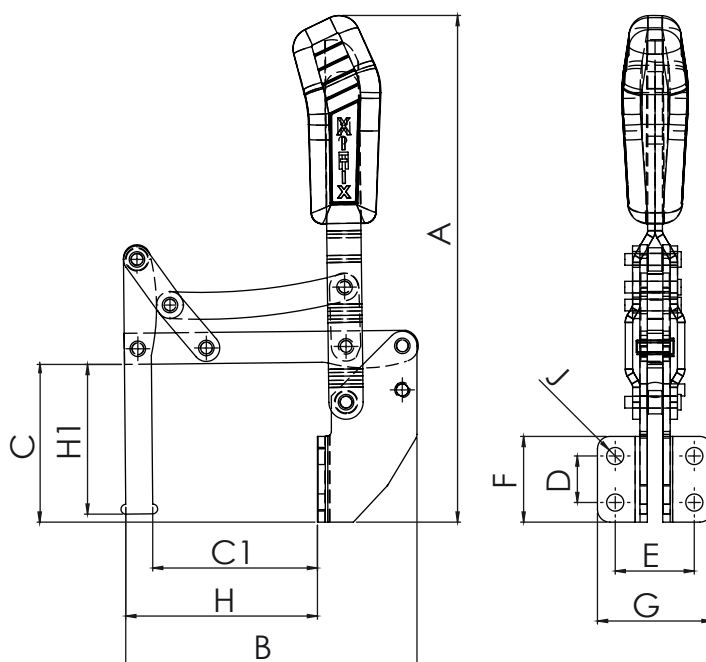
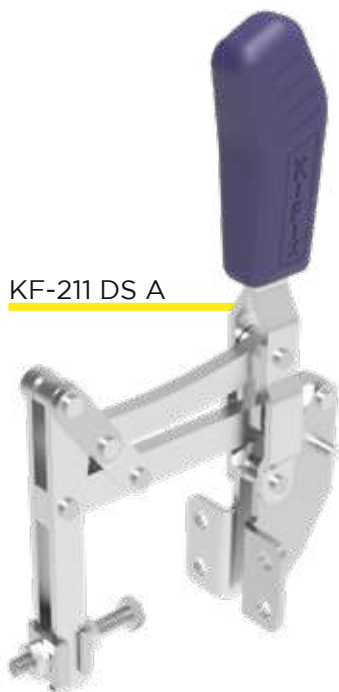

REFERENCE Referencia	RETENTION FORCE KGf (LBF) Fuerza Retención Kgf (lbf)	A (IN)	B (IN)	C (IN)	C1 (IN)	D (IN)	E (IN)	F (IN)	G (IN)	H (IN)	H1 (IN)	J (IN)	SPINDLE Tornillo	OPENING ANGLE Angulo de Apertura	WEIGHT KG (LB) Peso
KF-211 DS A	160 (352)	207 (8,15)	120 (4,72)	65 (2,56)	67,5 (2,66)	19 (0,75)	32 (1,26)	35 (1,38)	46,5 (1,83)	79 (3,11)	61 (2,40)	7,0 (0,28)	M6	100	0,560 (1,232)
KF-311 DS A	240 (528)	260 (10,24)	166 (6,54)	90 (3,54)	90 (3,54)	32 (1,26)	44 (1,73)	49 (1,93)	60 (2,36)	106 (4,17)	78 (3,07)	8,5 (0,33)	M8	100	1,240 (2,728)
KF-411 DS A	560 (1232)	321 (12,64)	200 (7,87)	113 (4,45)	114 (4,49)	32 (1,26)	45 (1,77)	55 (2,17)	67 (2,64)	134 (5,28)	92 (3,62)	8,5 (0,33)	M10	100	2,250 (4,950)

# VERTICAL HOLD-DOWN TOGGLE CLAMP PRENSA RÁPIDA VERTICAL

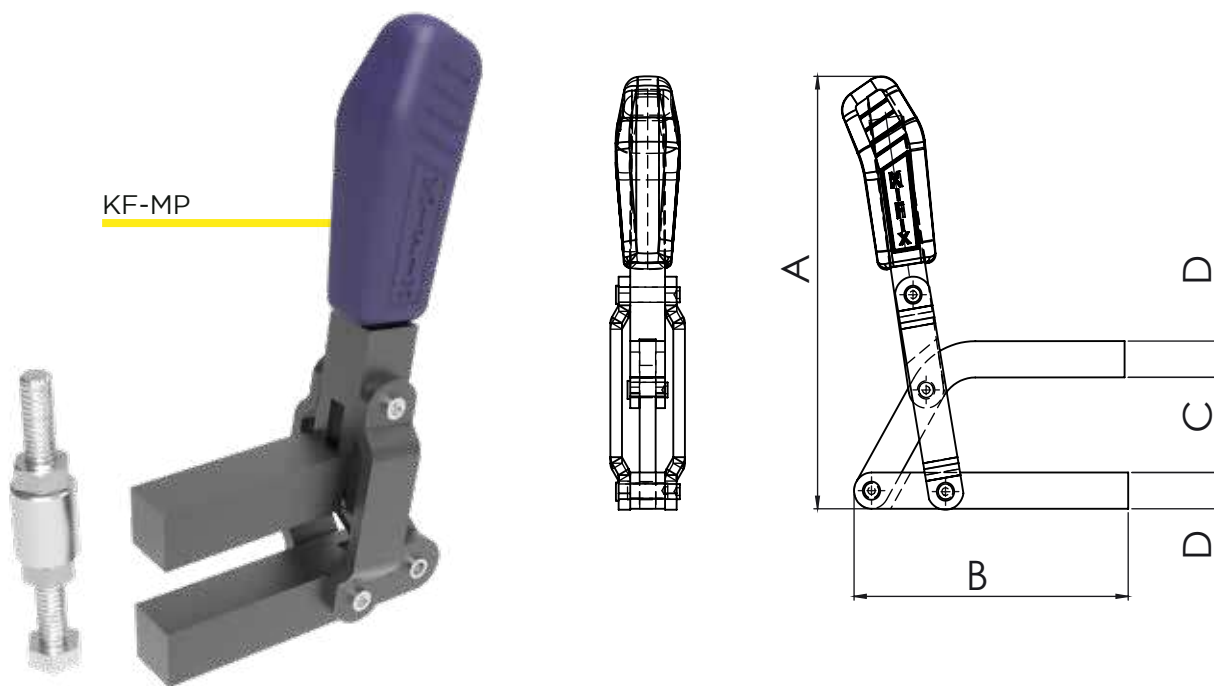

REFERENCE	RETENTION FORCE KGF (LBF)	A (IN)	B (IN)	C (IN)	D (IN)	SPINDLE	OPENING ANGLE	WEIGHT KG (LB)
Referencia	Fuerza Retención Kgf (lbf)					Tornillo	Angulo de Apertura	Peso
KF-01 MP	160 (352)	125 (4,92)	70 (2,76)	15 (0,59)	12,7 (0,50)	M6	120	0,320 (0,704)
KF-02 MP	300 (660)	171 (6,73)	92 (3,62)	20 (0,79)	14,3 (0,56)	M8	120	0,580 (1,276)
KF-03 MP	450 (990)	191 (7,52)	101 (3,98)	30 (1,18)	15,8 (0,62)	M8	120	1,350 (2,970)
KF-05 MP	500 (1100)	227 (8,94)	150 (5,91)	50 (1,97)	19,1 (0,75)	M10	120	2,040 (4,488)
KF-06 MP	500 (1100)	247 (9,72)	161 (6,34)	60 (2,36)	19,1 (0,75)	M10	120	2,135 (4,697)
KF-09 MP	1800 (3960)	324 (12,76)	200 (7,87)	90 (3,54)	25,4 (1,00)	M12	120	4,250 (9,350)

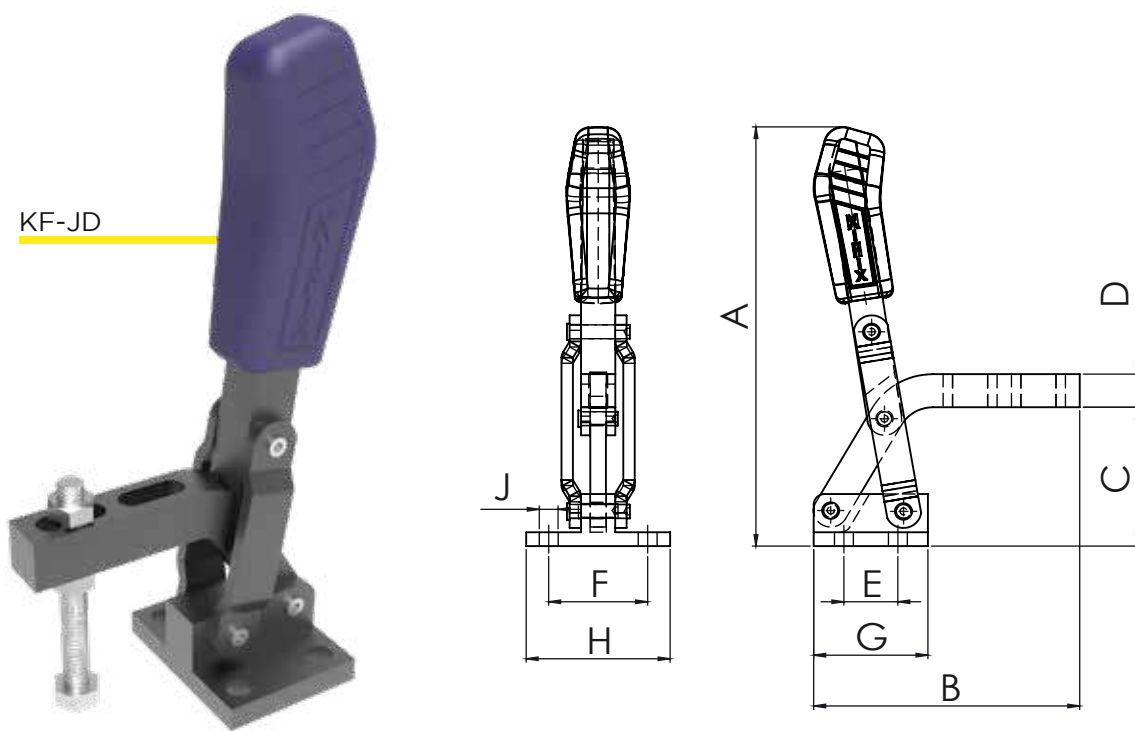

REFERENCE	RETENTION FORCE KGF (LBF)	A (IN)	B (IN)	C (IN)	D (IN)	E (IN)	F (IN)	G (IN)	H (IN)	J (IN)	SPINDLE	OPENING ANGLE	WEIGHT KG (LB)
Referencia	Fuerza Retención Kgf (lbf)										Tornillo	Angulo de Apertura	Peso
KF-03 JD	450 (990)	206 (8,11)	101 (3,98)	56 (2,20)	15,8 (0,62)	32 (1,26)	44 (1,73)	48 (1,89)	60 (2,36)	8,5 (0,33)	M8	120	1,360 (2,992)
KF-05 JD	500 (1100)	241 (9,49)	148 (5,83)	80 (3,15)	19,1 (0,75)	30 (1,18)	55 (2,17)	63,5 (2,50)	80 (3,15)	10,5 (0,41)	M10	120	2,100 (4,620)

# VERTICAL HOLD-DOWN TOGGLE CLAMP PRENSA RÁPIDA VERTICAL

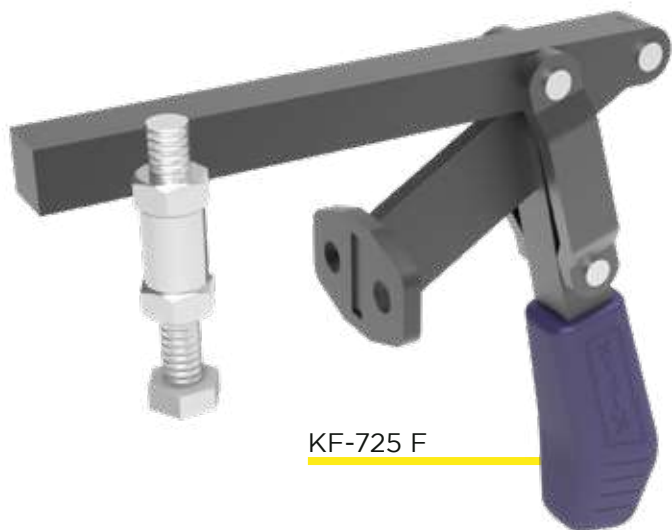

**KF-725 F**

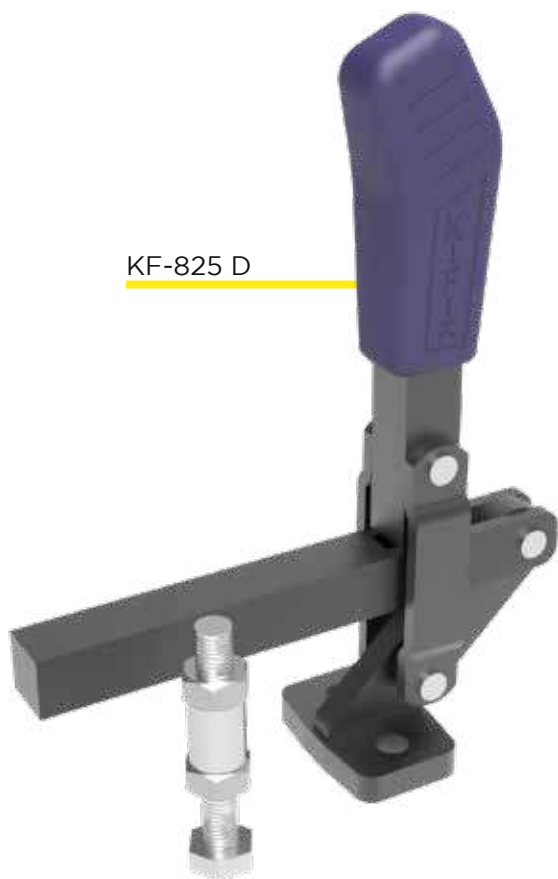
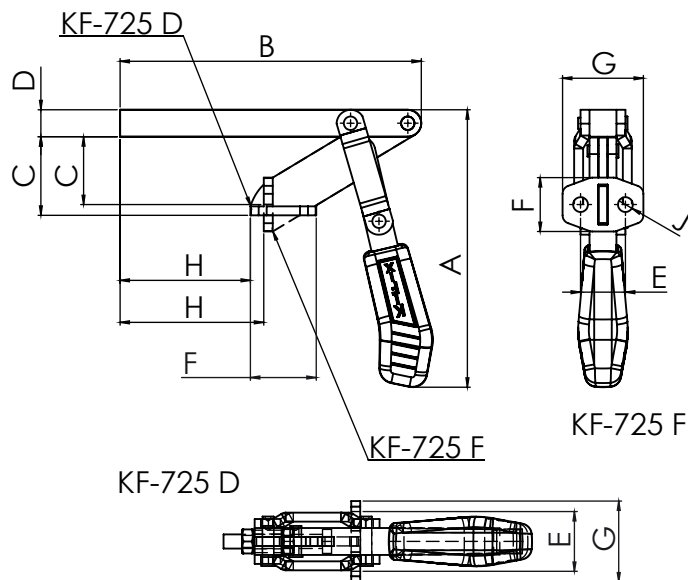

**KF-825 D**

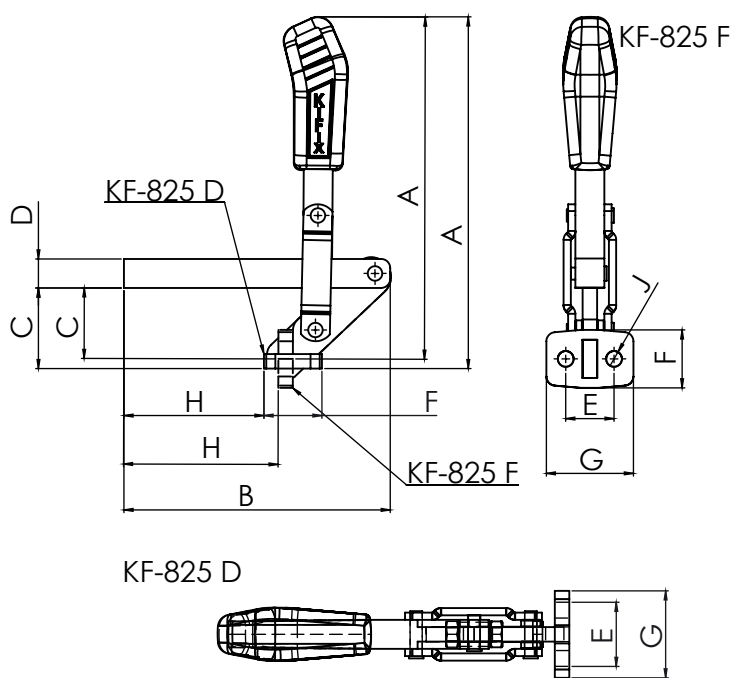

**BASES**  
D - Flanged Base  
F - Front

**PIES**  
D - Doblado  
F - Frontal

REFERENCE	RETENTION FORCE KGf (LBF)	A (IN)	B (IN)	C (IN)	D (IN)	E (IN)	F (IN)	G (IN)	H (IN)	J (IN)	SPINDLE	OPENING ANGLE	WEIGHT KG (LB)
Referencia	Fuerza Retención Kgf (lbf)										Tornillo	Angulo de Apertura	Peso
KF-725 D	450 (990)	196 (7,72)	213 (8,39)	55,6 (2,19)	19 (0,75)	32 (1,26)	38,1 (1,50)	57,2 (2,25)	92,2 (3,63)	10,5 (0,41)	M10	195	2,030 (4,466)
KF-725 F	450 (990)	196 (7,72)	213 (8,39)	48 (1,89)	19 (0,75)	32 (1,26)	38,1 (1,50)	57,2 (2,25)	101,6 (4,00)	10,5 (0,41)	M10	195	2,030 (4,466)
KF-825 D	450 (990)	231 (9,09)	175 (6,89)	53 (2,09)	19 (0,75)	32 (1,26)	38,1 (1,50)	57,2 (2,25)	92,2 (3,63)	10,5 (0,41)	M10	195	1,850 (4,070)
KF-825 F	450 (990)	225 (8,86)	175 (6,89)	46,7 (1,84)	19 (0,75)	32 (1,26)	38,1 (1,50)	57,2 (2,25)	101,6 (4,00)	10,5 (0,41)	M10	195	1,850 (4,070)

# VERTICAL HOLD-DOWN TOGGLE CLAMP PRENSA RÁPIDA VERTICAL

**KFU A**  
Triangular Base  
Base Triangular

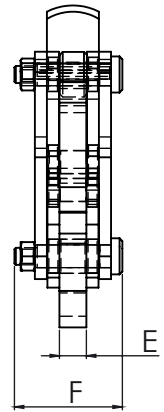
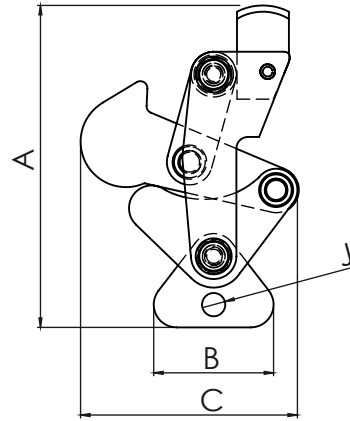

**KFU D**  
T Base  
Base T

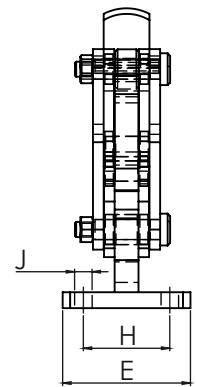
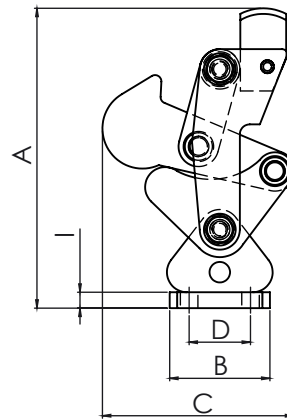

**KFU R**  
Double Straight Base  
Base Recta Doble

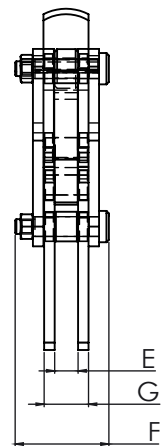
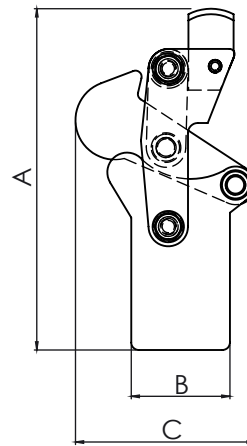

REFERENCE	RETENTION FORCE KGF (LBF)	A (IN)	B (IN)	C (IN)	D (IN)	E (IN)	F (IN)	G (IN)	H (IN)	I (IN)	J (IN)	SPINDLE	OPENING ANGLE	WEIGHT KG (LB)
Referencia	Fuerza Retención Kgf (lbf)											Tornillo	Angulo de Apertura	Peso
KFU-03 A	680 (1496)	105 (4,13)	42 (1,65)	72 (2,83)	-	9,5 (0,37)	42 (1,65)	-	-	-	8,5 (0,33)	M6	200	0,670 (1,474)
KFU-03 D	680 (1496)	112 (4,41)	40 (1,57)	72 (2,83)	4,5 (0,96)	51 (2,01)	42 (1,65)	-	34,5 (1,36)	6,35 (0,25)	7	M6	200	0,76
KFU-03 R	680 (1496)	130 (5,12)	40 (1,57)	68 (2,68)	-	9,5 (0,37)	42 (1,65)	18 (0,71)	-	-	-	M6	200	0,730 (1,606)
KFU-05 A	1000 (2200)	145 (5,71)	60 (2,36)	98 (3,86)	-	12,7 (0,50)	47 (1,85)	-	-	-	10,5 (0,41)	M10	200	1,170 (2,574)
KFU-05 D	1000 (2200)	153 (6,02)	55 (2,17)	98 (3,86)	31,5 (1,24)	64 (2,52)	47 (1,85)	-	45 (1,77)	8 (0,31)	8,5 (0,33)	M10	200	1,380 (3,036)
KFU-05 R	1000 (2200)	170 (6,69)	50 (1,97)	92 (3,62)	-	12,7 (0,50)	47 (1,85)	22 (0,87)	-	-	-	M10	200	1,240 (2,728)
KFU-06 A	2200 (4840)	176 (6,93)	70 (2,76)	118 (4,65)	-	15,9 (0,63)	66 (2,60)	-	-	-	125 (0,49)	M10	200	2,720 (5,984)
KFU-06 D	2200 (4840)	186 (7,32)	70 (2,76)	118 (4,65)	40 (1,57)	80 (3,15)	66 (2,60)	-	50 (1,97)	9,5 (0,37)	10,5 (0,41)	M10	200	3,110 (6,842)
KFU-06 R	2200 (4840)	211 (8,31)	65 (2,56)	114 (4,49)	-	15,9 (0,63)	66 (2,60)	29 (1,14)	-	-	-	M10	200	2,900 (6,380)
KFU-08 A	2200 (4840)	247 (9,72)	84 (3,31)	177 (6,97)	-	19 (0,75)	72,5 (2,85)	-	-	-	13,0 (0,51)	M12	200	6,440 (14,168)
KFU-08 D	3500 (7700)	260 (10,24)	100 (3,94)	177 (6,97)	70 (2,76)	150 (5,91)	72,5 (2,85)	-	120 (4,72)	12,7 (0,50)	10,5 (0,41)	M12	200	7,830 (17,226)
KFU-08 R	3500 (7700)	273 (10,75)	80,6 (3,17)	177 (6,97)	-	19 (0,75)	72,5 (2,85)	35 (1,38)	-	-	-	M12	200	6,270 (13,794)

# HORIZONTAL HOLD-DOWN TOGGLE CLAMP PRENSA RÁPIDA HORIZONTAL

KF-105 D



KF-106 D



KF-105 DU



KF-107 D

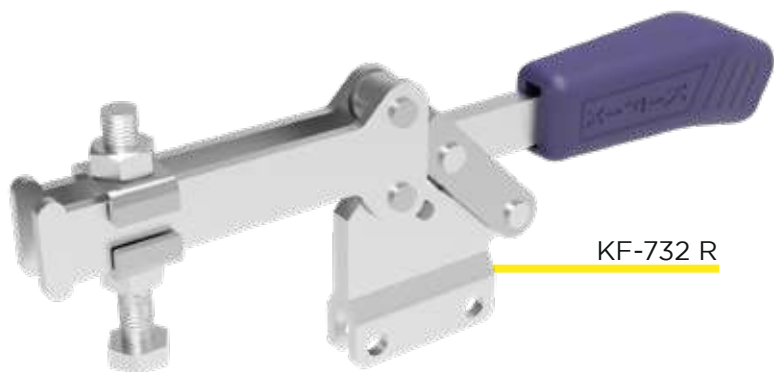

KF-732 R

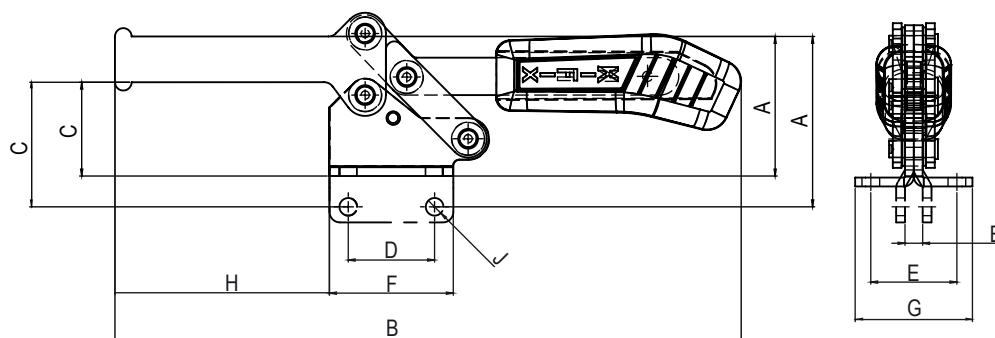

**BASES**  
 D - Flanged Base  
 R - Straight Base  
 DU - Flanged Only Base

**PIES**  
 D - Doblado  
 R - Recto  
 DU - Doblado solo

REFERENCE	RETENTION FORCE KGF (LBF)	A (IN)	B (IN)	C (IN)	D (IN)	E (IN)	F (IN)	G (IN)	H (IN)	J (IN)	SPINDLE	OPENING ANGLE	WEIGHT KG (LB)
Referencia	Fuerza Retención Kgf (lbf)										Tornillo	Angulo de Apertura	Peso
KF-105 D	30 (66)	18 (0.71)	64 (2.52)	8 (0.31)	13.5 (0.53)	16 (0.63)	24 (0.94)	24 (0.94)	18.6 (0.73)	4.3 (0.17)	M4	90	0.030 (0.066)
KF-105 DU	30 (66)	21.3 (0.84)	64 (2.52)	8 (0.31)	13.5 (0.53)	8 (0.31)	24 (0.94)	12 (0.47)	18.6 (0.73)	4.3 (0.17)	M4	90	0.030 (0.066)
KF-105 R	30 (66)	24 (0.94)	64 (2.52)	12 (0.47)	13.5 (0.53)	-	24 (0.94)	-	18.6 (0.73)	4.3 (0.17)	M4	90	0.030 (0.066)
KF-106 D	70 (154)	35 (1.38)	112 (4.41)	20 (0.79)	13.5 (0.53)	18.3 (0.72)	25.5 (1.00)	28 (1.10)	35 (1.38)	4.5 (0.18)	M6	90	0.095 (0.209)
KF-106 R	70 (154)	40 (1.57)	112 (4.41)	24 (0.94)	13.5 (0.53)	4 (0.16)	25.5 (1.00)	-	35 (1.38)	4.5 (0.18)	M6	90	0.095 (0.209)
KF-107 D	70 (154)	45 (1.77)	136 (5.35)	22 (0.86)	12.7 (0.50)	12 (0.47)	26 (1.00)	35 (1.37)	51 (2.00)	5.5 (0.21)	M6	70	0.180 (0.39)
KF-152 D	130 (286)	46 (1.81)	184 (7.24)	25 (0.98)	20 (0.79)	25.5 (1.00)	38 (1.50)	37 (1.46)	58 (2.28)	7.0 (0.28)	M6	90	0.280 (0.616)
KF-152 R	130 (286)	54 (2.13)	184 (7.24)	32 (1.26)	20 (0.79)	6 (0.24)	38 (1.50)	-	58 (2.28)	7.0 (0.28)	M6	90	0.280 (0.616)
KF-732 D	340 (748)	79 (3.11)	301 (11.85)	45 (1.77)	42 (1.65)	42 (1.65)	60 (2.36)	57 (2.24)	103 (4.06)	8.5 (0.33)	M10	80	1.030 (2.266)
KF-732 R	340 (748)	93 (3.66)	301 (11.85)	60 (2.36)	42 (1.65)	8.5 (0.33)	60 (2.36)	-	103 (4.06)	8.5 (0.33)	M10	80	1.030 (2.266)



# HORIZONTAL HOLD-DOWN TOGGLE CLAMP PRENSA RÁPIDA HORIZONTAL

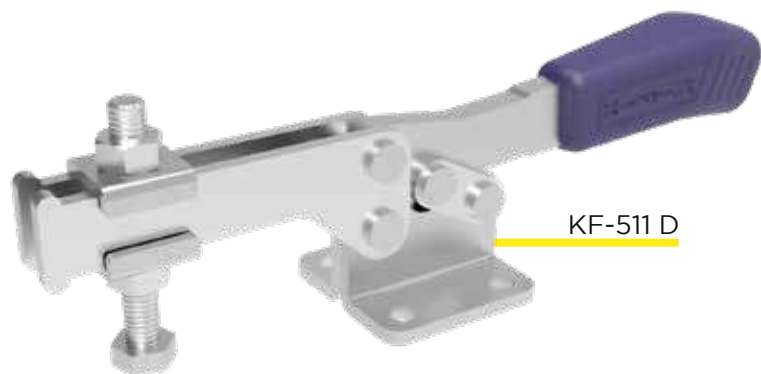

KF-511 D

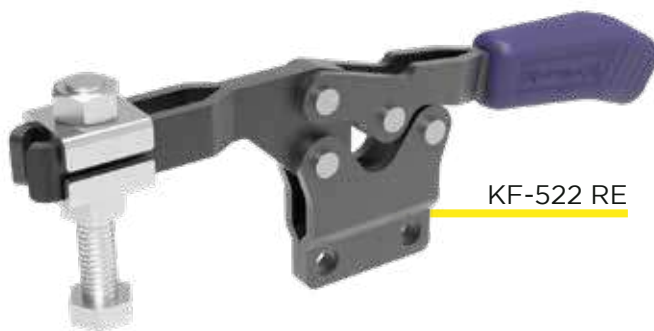

KF-522 RE

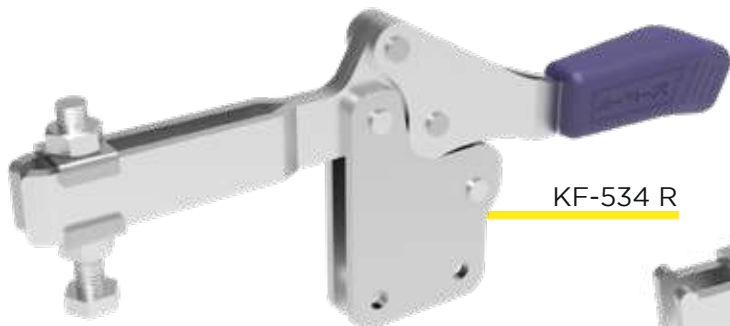

KF-534 R

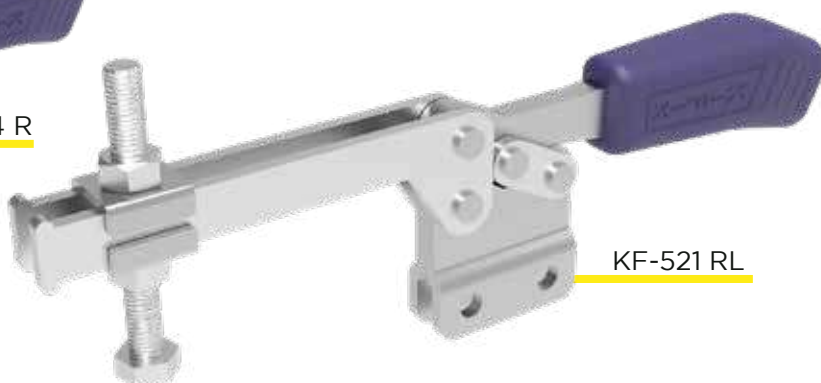

KF-521 RL

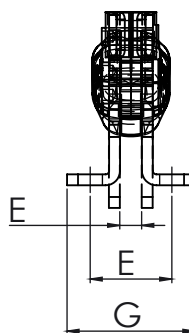
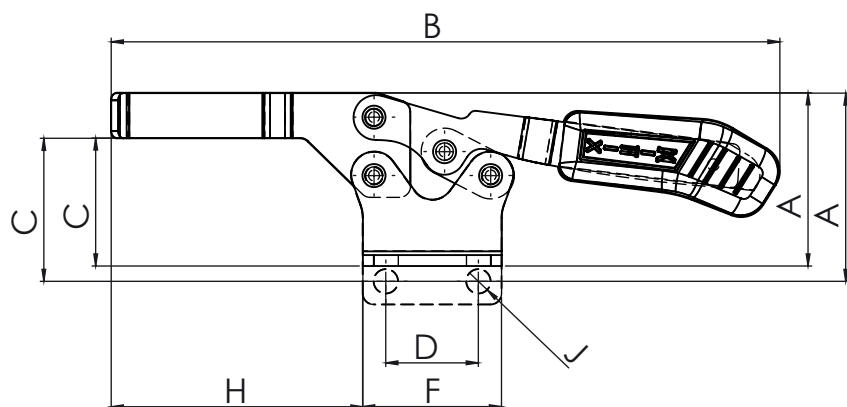

**BASES**  
D - Flanged Base  
R - Straight Base  
E - Front Base

**BAR**  
L - Long U-Bar

TR - with  
Toggle-  
Lock Plus

**PIES**  
D - Doblado  
R - Recto  
E - Especial

**BRAZO**  
L - Largo

TR -  
Bloqueo

REFERENCE	RETENTION FORCE KGf (LBF)	A (IN)	B (IN)	C (IN)	D (IN)	E (IN)	F (IN)	G (IN)	H (IN)	J (IN)	SPINDLE	OPENING ANGLE	WEIGHT KG (LB)
Referencia	Fuerza Retención Kgf (lbf)										Tornillo	Angulo de Apertura	Peso
KF-511 D	90 (198)	47 (1.85)	172 (6.77)	26 (1.02)	24 (0.94)	26 (1.02)	36 (1.42)	37 (1.46)	59 (2.32)	5.5 (0.22)	M6	70	0.240 (0.528)
KF-511 R	90 (198)	55 (2.17)	172 (6.77)	34 (1.34)	24 (0.94)	6.5 (0.26)	36 (1.42)	-	59 (2.32)	5.5 (0.22)	M6	70	0.240 (0.528)
KF-512 D	90 (198)	39 (1.54)	146 (5.75)	26 (1.02)	25.4 (1.00)	22.4 (0.88)	37 (1.46)	35 (1.38)	57 (2.24)	5.3 (0.21)	M6	90	0.150 (0.330)
KF-512 R	90 (198)	45 (1.77)	146 (5.75)	32 (1.26)	25.4 (1.00)	4.5 (0.18)	37 (1.46)	-	57 (2.24)	5.3 (0.21)	M6	90	0.150 (0.330)
KF-521 D	130 (286)	51 (2.01)	208 (8.19)	36 (1.42)	25.4 (1.00)	24 (0.94)	45 (1.77)	42 (1.65)	68 (2.68)	7.0 (0.28)	M8	70	0.440 (0.968)
KF-521 D TR	130 (286)	51 (2.01)	235 (9.25)	36 (1.42)	25.4 (1.00)	24 (0.94)	45 (1.77)	42 (1.65)	68 (2.68)	7.0 (0.28)	M8	70	0.480 (1.056)
KF-521 DL	100 (220)	51 (2.01)	243 (9.57)	36 (1.42)	25.4 (1.00)	24 (0.94)	45 (1.77)	42 (1.65)	103 (4.06)	7.0 (0.28)	M8	70	0.470 (1.034)
KF-521 R	130 (286)	57 (2.24)	208 (8.19)	42 (1.65)	25.4 (1.00)	6.5 (0.26)	45 (1.77)	-	68 (2.68)	7.0 (0.28)	M8	70	0.440 (0.968)
KF-521 RL	100 (220)	57 (2.24)	243 (9.57)	42 (1.65)	25.4 (1.00)	6.5 (0.26)	45 (1.77)	-	103 (4.06)	7.0 (0.28)	M8	70	0.470 (1.034)
KF-522 D	230 (506)	48 (1.89)	184 (7.24)	35 (1.38)	25.4 (1.00)	22.4 (0.88)	38 (1.50)	35 (1.38)	69 (2.72)	6.7 (0.26)	M8	90	0.295 (0.649)
KF-522 R	230 (506)	52 (2.05)	184 (7.24)	39 (1.54)	25.4 (1.00)	6 (0.24)	38 (1.50)	-	69 (2.72)	6.7 (0.26)	M8	90	0.295 (0.649)
KF-522 RE	230 (506)	52 (2.05)	184 (7.24)	39 (1.54)	25.4 (1.00)	0 (0.00)	38 (1.50)	-	69 (2.72)	6.7 (0.26)	M8	90	0.295 (0.649)
KF-532 D	340 (748)	65 (2.56)	294 (11.57)	45 (1.77)	41 (1.61)	42 (1.65)	57 (2.24)	58 (2.28)	105 (4.13)	8.5 (0.33)	M10	90	0.860 (1.892)
KF-532 R	340 (748)	76 (2.99)	294 (11.57)	56 (2.20)	41 (1.61)	8.5 (0.33)	57 (2.24)	-	105 (4.13)	8.5 (0.33)	M10	90	0.860 (1.892)
KF-532 D TR	340 (748)	65 (2.56)	294 (11.57)	45 (1.77)	41 (1.61)	42 (1.65)	57 (2.24)	58 (2.28)	105 (4.13)	8.5 (0.33)	M10	90	0.920 (2.024)
KF-534 D	450 (990)	107.7 (4.24)	335 (13.19)	57.2 (2.25)	41.3 (1.63)	41.3 (1.63)	66.7 (2.63)	66.7 (2.63)	123.7 (4.87)	8.5 (0.33)	M10	100	1.450 (3.190)
KF-534 R	450 (990)	116 (4.57)	335 (13.19)	65.4 (2.57)	41.3 (1.63)	9.5 (0.37)	66.7 (2.63)	-	123.7 (4.87)	8.5 (0.33)	M10	100	1.450 (3.190)

# HORIZONTAL HOLD-DOWN TOGGLE CLAMP PRENSA RÁPIDA HORIZONTAL

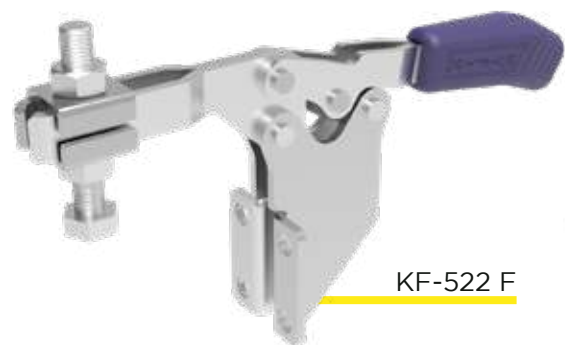

KF-522 F

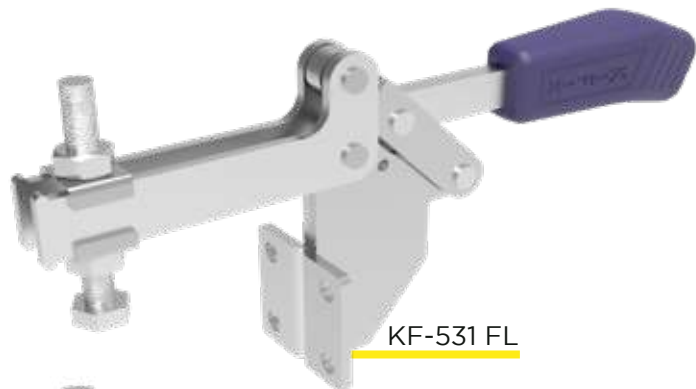
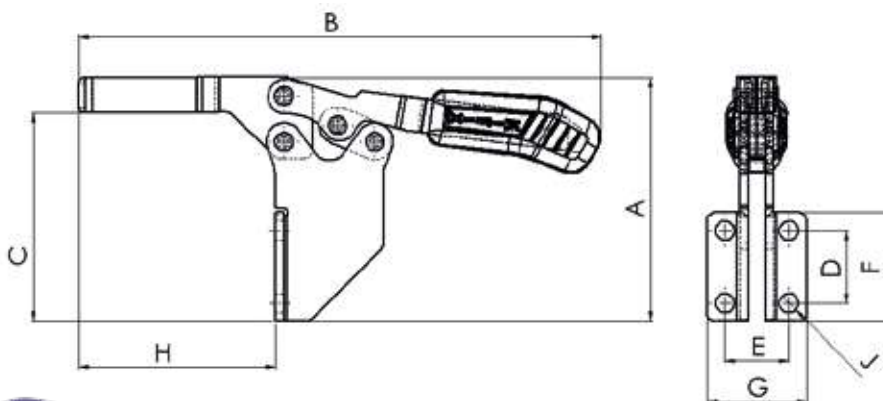

KF-531 FL

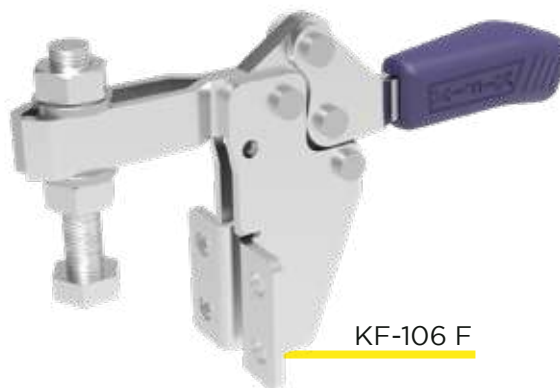

KF-106 F

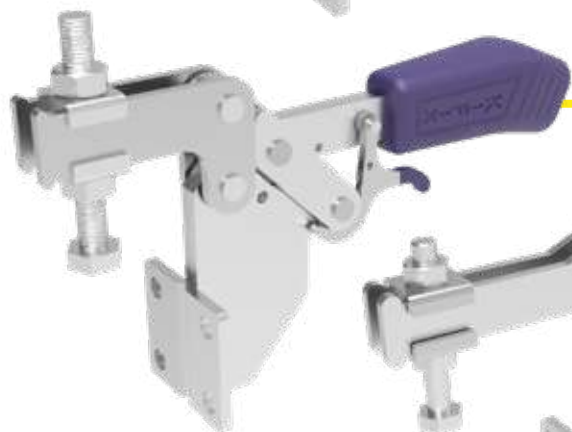

KF-531 FI TR

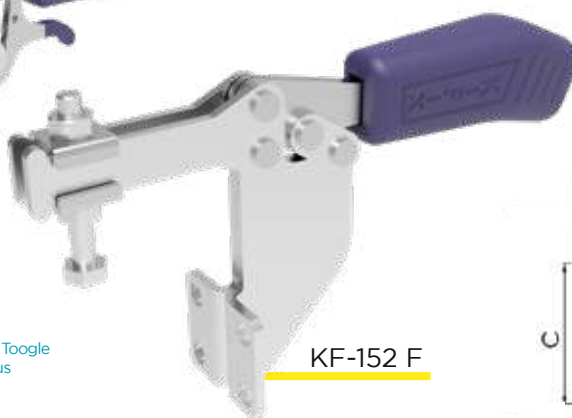

KF-152 F

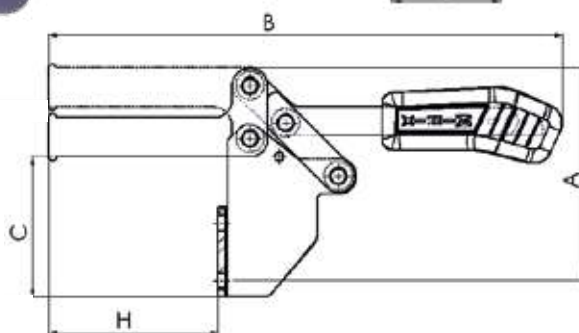
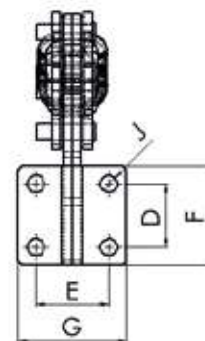

**BASES**  
F - Front Base

**BAR**  
L - Long U-Bar  
I - Inverted

TR - With Toggle  
- Lock Plus

**PIES**  
F - Frontal

**BRAZO**  
L - Largo  
I - Invertido

TR - Bloqueo

REFERENCE	RETENTION FORCE KGf (LBF)	A (IN)	B (IN)	C (IN)	D (IN)	E (IN)	F (IN)	G (IN)	H (IN)	J (IN)	SPINDLE	OPENING ANGLE	WEIGHT KG (LB)
Referencia	Fuerza Retención Kgf (lbf)										Tornillo	Angulo de Apertura	Peso
KF-106 F	70 (154)	56 (220)	112 (4.41)	40 (1.57)	13.5 (0.53)	18.3 (0.72)	25.5 (1.00)	28 (1.10)	35 (1.38)	4.5 (0.18)	M6	90	0,110 (0,242)
KF-107 F	70 (154)	74 (2.91)	127 (5.00)	31 (1.22)	12.7 (0.50)	22 (0.86)	25 (0.98)	35 (1.38)	47 (1.85)	5.5 (0.28)	M6	90	0,200 (0,440)
KF-312 F	70 (154)	59 (2.32)	117 (4.60)	42 (1.65)	13.5 (0.53)	18.6 (0.73)	25.5 (1.00)	28 (1.10)	41 (1.61)	5 (0.18)	M6	90	0,103 (0,227)
KF-152 FL	90 (198)	95 (3.74)	201 (7.91)	74 (2.91)	20 (0.78)	25.5 (1.00)	32 (1.25)	37 (1.45)	70 (2.75)	7.0 (0.27)	M6	90	0,343 (0,756)
KF-152 F	130 (286)	95 (3.74)	184 (7.24)	74 (2.91)	20 (0.78)	25.5 (1.00)	35 (1.37)	37 (1.45)	52 (2.04)	7.0 (0.27)	M8	90	0,340 (0,749)
KF-522 F	230 (506)	85 (3.35)	184 (7.24)	73 (2.87)	25.4 (1.00)	22.4 (0.88)	38 (1.50)	35 (1.38)	69 (2.72)	6.7 (0.26)	M8	90	0,335 (0,737)
KF-522 FL	200 (440)	85 (3.35)	214 (8.43)	73 (2.87)	25.4 (1.00)	22.4 (0.88)	38 (1.50)	35 (1.38)	99 (3.90)	6.7 (0.26)	M8	90	0,350 (0,770)
KF-531 F	400 (880)	119 (4.69)	245 (9.65)	78 (3.07)	32 (1.26)	37 (1.46)	50 (1.97)	55 (2.17)	52 (2.05)	8.5 (0.33)	M8	80	1,035 (2,277)
KF-531 FI	400 (880)	119 (4.69)	245 (9.65)	106 (4.17)	32 (1.26)	37 (1.46)	50 (1.97)	55 (2.17)	52 (2.05)	8.5 (0.33)	M8	80	1,035 (2,277)
KF-531 FL	300 (660)	119 (4.69)	287 (11.30)	78 (3.07)	32 (1.26)	37 (1.46)	50 (1.97)	55 (2.17)	95 (3.74)	8.5 (0.33)	M8	80	1,095 (2,409)
KF-531 FIL	300 (660)	119 (4.69)	287 (11.30)	106 (4.17)	32 (1.26)	37 (1.46)	50 (1.97)	55 (2.17)	95 (3.74)	8.5 (0.33)	M10	80	1,095 (2,409)
KF-531 F TR	400 (880)	119 (4.69)	245 (9.65)	78 (3.07)	32 (1.26)	37 (1.46)	50 (1.97)	55 (2.17)	52 (2.05)	8.5 (0.33)	M10	80	1,070 (2,354)
KF-531 FI TR	400 (880)	119 (4.69)	245 (9.65)	106 (4.17)	32 (1.26)	37 (1.46)	50 (1.97)	55 (2.17)	52 (2.05)	8.5 (0.33)	M10	80	1,070 (2,354)
KF-531 FL TR	300 (660)	119 (4.69)	287 (11.30)	78 (3.07)	32 (1.26)	37 (1.46)	50 (1.97)	55 (2.17)	95 (3.74)	8.5 (0.33)	M10	80	1,130 (2,486)
KF-531 FIL TR	300 (660)	119 (4.69)	287 (11.30)	106 (4.17)	32 (1.26)	37 (1.46)	50 (1.97)	55 (2.17)	95 (3.74)	8.5 (0.33)	M10	80	1,130 (2,486)

# HORIZONTAL HOLD-DOWN TOGGLE CLAMP PRENSA RÁPIDA HORIZONTAL



KF-531 D TR

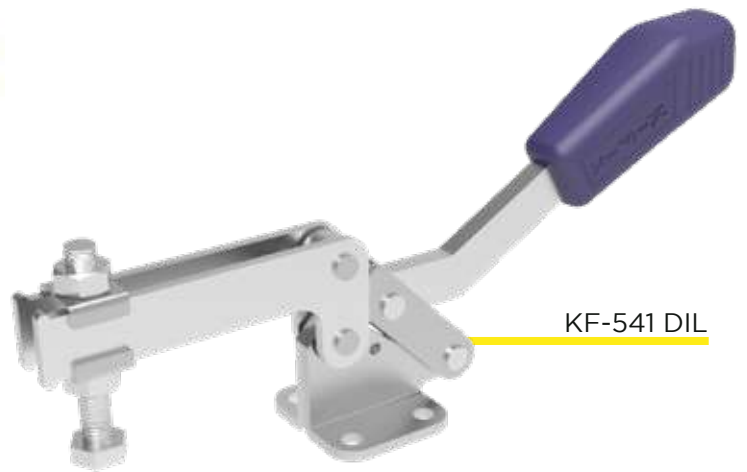

KF-541 DIL

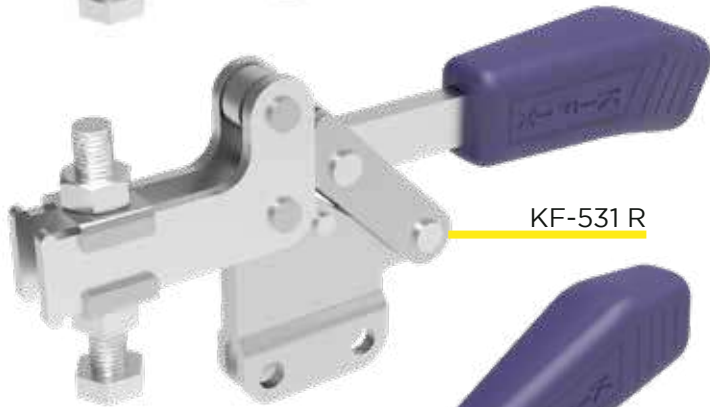

KF-531 R

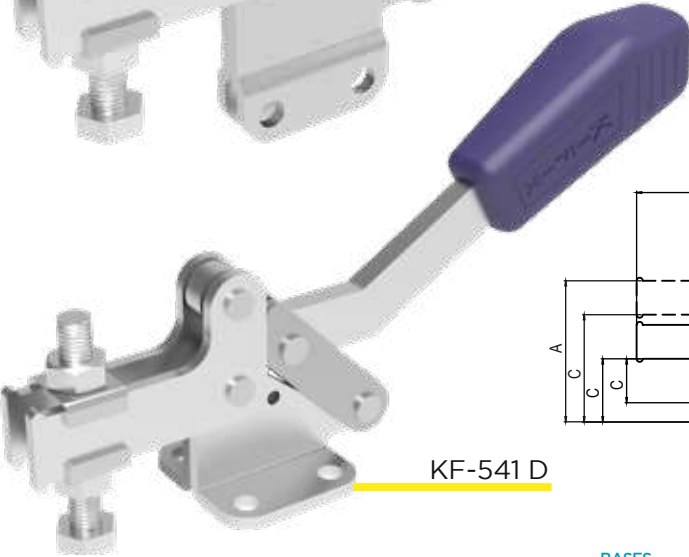

KF-541 D

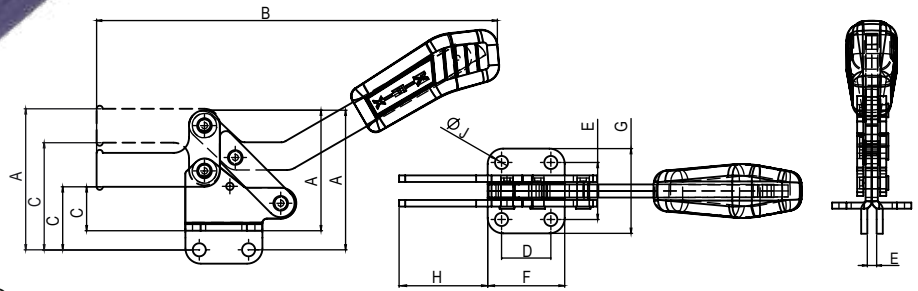
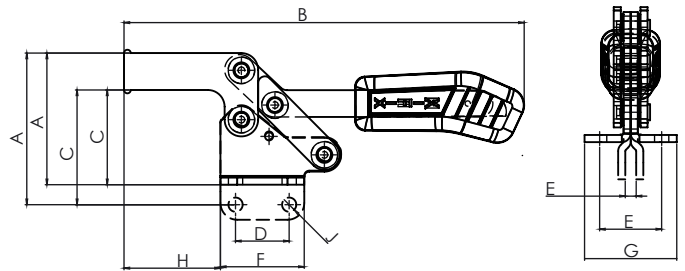

**BASES**  
D - Flanged Base  
R - Straight Base

**BAR**  
L - Long U-Bar

TR - With Toggle  
- Lock Plus

**PIES**  
D - Doblado  
R - Recto

**BRAZO**  
L - Largo

TR - Bloqueo

REFERENCE	RETENTION FORCE KGf (LBF)	A (IN)	B (IN)	C (IN)	D (IN)	E (IN)	F (IN)	G (IN)	H (IN)	J (IN)	SPINDLE	OPENING ANGLE	WEIGHT KG (LB)
Referencia	Fuerza Retención Kgf (lbf)										Tornillo	Angulo de Apertura	Peso
KF-531 D	400 (880)	78 (3,07)	239 (9,41)	28 (1,10)	32 (1,26)	37 (1,46)	50 (1,97)	55 (2,17)	57 (2,24)	8,5 (0,33)	M10	80	0,870 (1,914)
KF-531 DI	400 (880)	78 (3,07)	239 (9,41)	56 (2,20)	32 (1,26)	37 (1,46)	50 (1,97)	55 (2,17)	57 (2,24)	8,5 (0,33)	M10	80	0,870 (1,914)
KF-531 R	400 (880)	91 (3,58)	239 (9,41)	41 (1,61)	32 (1,26)	6,5 (0,26)	50 (1,97)	-	57 (2,24)	8,5 (0,33)	M10	80	0,870 (1,914)
KF-531 RI	400 (880)	91 (3,58)	239 (9,41)	69 (2,72)	32 (1,26)	6,5 (0,26)	50 (1,97)	-	57 (2,24)	8,5 (0,33)	M10	80	0,870 (1,914)
KF-531 DL	300 (660)	78 (3,07)	281 (11,06)	28 (1,10)	32 (1,26)	37 (1,46)	50 (1,97)	55 (2,17)	100 (3,94)	8,5 (0,33)	M10	80	0,940 (2,068)
KF-531 DIL	300 (660)	78 (3,07)	281 (11,06)	56 (2,20)	32 (1,26)	37 (1,46)	50 (1,97)	55 (2,17)	100 (3,94)	8,5 (0,33)	M10	80	0,940 (2,068)
KF-531 RL	300 (660)	91 (3,58)	281 (11,06)	41 (1,61)	32 (1,26)	6,5 (0,26)	50 (1,97)	-	100 (3,94)	8,5 (0,33)	M10	80	0,940 (2,068)
KF-531 RIL	300 (660)	91 (3,58)	281 (11,06)	69 (2,72)	32 (1,26)	6,5 (0,26)	50 (1,97)	-	100 (3,94)	8,5 (0,33)	M10	80	0,940 (2,068)
KF-531 D TR	400 (880)	78 (3,07)	245 (9,65)	28 (1,10)	32 (1,26)	37 (1,46)	50 (1,97)	55 (2,17)	57 (2,24)	8,5 (0,33)	M10	80	0,920 (2,024)
KF-531 DI TR	400 (880)	78 (3,07)	245 (9,65)	56 (2,20)	32 (1,26)	37 (1,46)	50 (1,97)	55 (2,17)	57 (2,24)	8,5 (0,33)	M10	80	0,920 (2,024)
KF-531 DL TR	300 (660)	78 (3,07)	287 (11,30)	28 (1,10)	32 (1,26)	37 (1,46)	50 (1,97)	55 (2,17)	100 (3,94)	8,5 (0,33)	M10	80	0,980 (2,156)
KF-531 DIL TR	300 (660)	78 (3,07)	287 (11,30)	56 (2,20)	32 (1,26)	37 (1,46)	50 (1,97)	55 (2,17)	100 (3,94)	8,5 (0,33)	M10	80	0,980 (2,156)
KF-541 D	400 (880)	78 (3,07)	261 (10,28)	28 (1,10)	32 (1,26)	37 (1,46)	50 (1,97)	55 (2,17)	57 (2,24)	8,5 (0,33)	M10	80	0,920 (2,024)
KF-541 DI	400 (880)	78 (3,07)	261 (10,28)	56 (2,20)	32 (1,26)	37 (1,46)	50 (1,97)	55 (2,17)	57 (2,24)	8,5 (0,33)	M10	80	0,920 (2,024)
KF-541 R	400 (880)	91 (3,58)	261 (10,28)	41 (1,61)	32 (1,26)	6,5 (0,26)	50 (1,97)	-	57 (2,24)	8,5 (0,33)	M10	80	0,920 (2,024)
KF-541 RI	400 (880)	91 (3,58)	261 (10,28)	69 (2,72)	32 (1,26)	6,5 (0,26)	50 (1,97)	-	57 (2,24)	8,5 (0,33)	M10	80	0,920 (2,024)
KF-541 DL	300 (660)	78 (3,07)	304 (11,97)	28 (1,10)	32 (1,26)	37 (1,46)	50 (1,97)	55 (2,17)	100 (3,94)	8,5 (0,33)	M10	80	0,960 (2,112)
KF-541 DIL	300 (660)	78 (3,07)	304 (11,97)	56 (2,20)	32 (1,26)	37 (1,46)	50 (1,97)	55 (2,17)	100 (3,94)	8,5 (0,33)	M10	80	0,960 (2,112)
KF-541 RL	300 (660)	91 (3,58)	304 (11,97)	41 (1,61)	32 (1,26)	6,5 (0,26)	50 (1,97)	-	100 (3,94)	8,5 (0,33)	M10	80	0,960 (2,112)
KF-541 RIL	300 (660)	91 (3,58)	304 (11,97)	69 (2,72)	32 (1,26)	6,5 (0,26)	50 (1,97)	-	100 (3,94)	8,5 (0,33)	M10	80	0,960 (2,112)

# HORIZONTAL HOLD-DOWN TOGGLE CLAMP PRENSA RÁPIDA HORIZONTAL

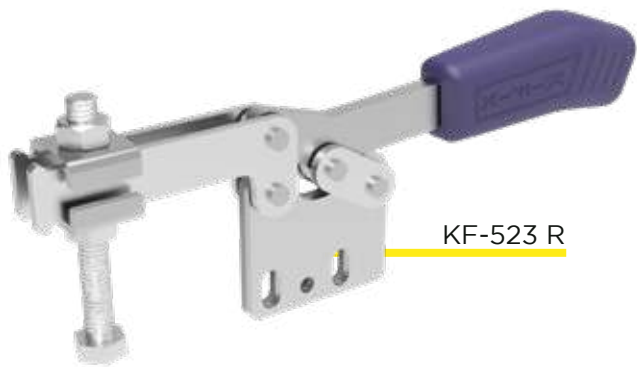

KF-523 R

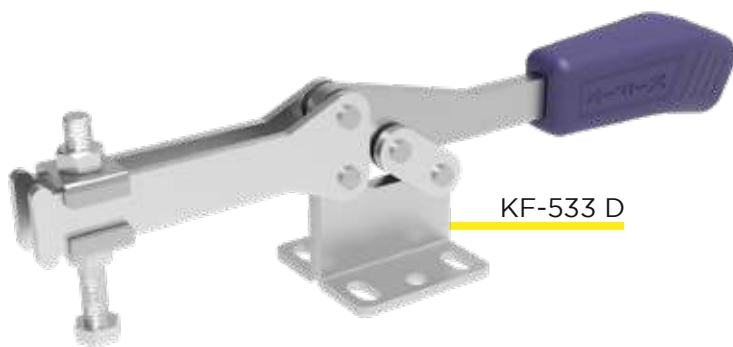

KF-533 D

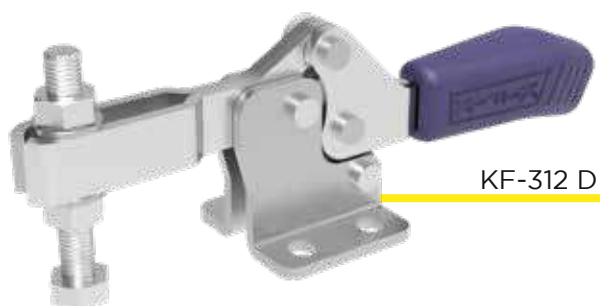

KF-312 D

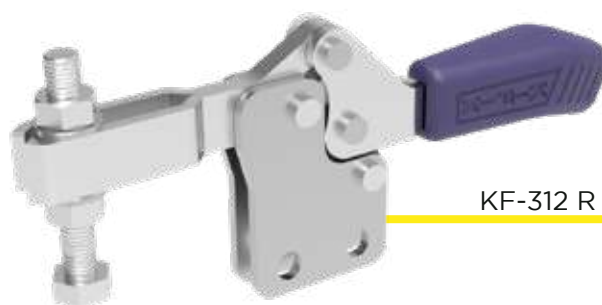

KF-312 R

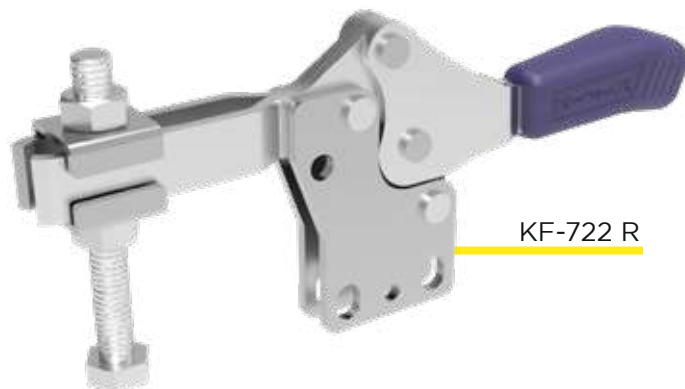
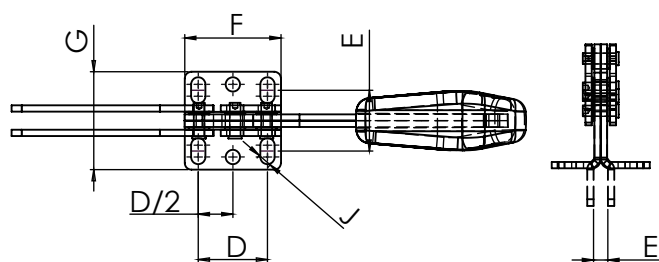
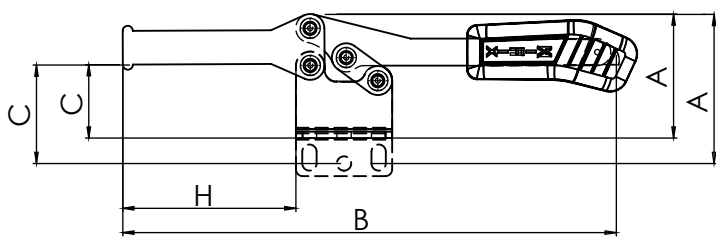

KF-722 R

**BASES**  
D - Flanged Base  
R - Straight Base

**PIES**  
D - Dobrada  
R - Reta

REFERENCE	RETENTION FORCE KGf (LBF)	A (IN)	B (IN)	C (IN)	D (IN)	E (IN)	F (IN)	G (IN)	H (IN)	J (IN)	SPINDLE	OPENING ANGLE	WEIGHT KG (LB)
Referencia	Fuerza Retención Kgf (lbf)										Tornillo	Angulo de Apertura	Peso
KF-312 D	70 (154)	35 (1,38)	112 (4,41)	19 (0,75)	13,5 (0,53)	17,3 (0,68)	25,4 (1,00)	27,2 (1,07)	36 (1,42)	4,3 (0,17)	M5	90	0,085 (0,187)
KF-312 R	70 (154)	39 (1,54)	112 (4,41)	23 (0,91)	13,5 (0,53)	4,2 (0,17)	25,4 (1,00)	-	36 (1,42)	4,3 (0,17)	M5	90	0,085 (0,187)
KF-712 D	120 (264)	50 (1,97)	183 (7,20)	26 (1,02)	26,2 (1,03)	26,1 (1,03)	37,3 (1,47)	40 (1,57)	59 (2,32)	5,5 (0,22)	M6	90	0,205 (0,451)
KF-712 R	120 (264)	64 (2,52)	183 (7,20)	35 (1,38)	26,2 (1,03)	5,2 (0,20)	37,3 (1,47)	-	59 (2,32)	5,5 (0,22)	M6	90	0,205 (0,451)
KF-523 D	180 (396)	57 (2,24)	221 (8,70)	33 (1,30)	25,7 (1,01)	26,9 (1,06)	50 (1,97)	44,5 (1,75)	66 (2,60)	6,5 (0,26)	M8	90	0,410 (0,902)
KF-523 R	180 (396)	74 (2,91)	221 (8,70)	41 (1,61)	25,7 (1,01)	-	50 (1,97)	-	66 (2,60)	6,5 (0,26)	M8	90	0,410 (0,902)
KF-722 D	230 (506)	61 (2,40)	192 (7,56)	34 (1,34)	26,2 (1,03)	28,4 (1,12)	39,6 (1,56)	43,2 (1,70)	68,5 (2,70)	7,0 (0,28)	M8	90	0,355 (0,781)
KF-722 R	230 (506)	70 (2,76)	192 (7,56)	42 (1,65)	26,2 (1,03)	6,2 (0,24)	39,6 (1,56)	-	68,5 (2,70)	7,0 (0,28)	M8	90	0,355 (0,781)
KF-533 D	340 (748)	73,5 (2,89)	305 (12,01)	43,5 (1,71)	41 (1,61)	36 (1,42)	57 (2,24)	58 (2,28)	102,5 (4,04)	8,5 (0,33)	M8	90	0,800 (1,760)
KF-533 R	340 (748)	88,3 (3,48)	305 (12,01)	58,3 (2,30)	41 (1,61)	8,5 (0,33)	57 (2,24)	-	102,5 (4,04)	8,5 (0,33)	M8	90	0,800 (1,760)

# HORIZONTAL HOLD-DOWN TOGGLE CLAMP PRENSA RÁPIDA HORIZONTAL



KF-102 D



KF-102 R CL

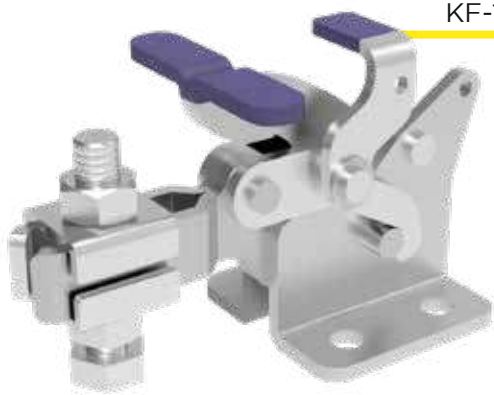

KF-103 D TR

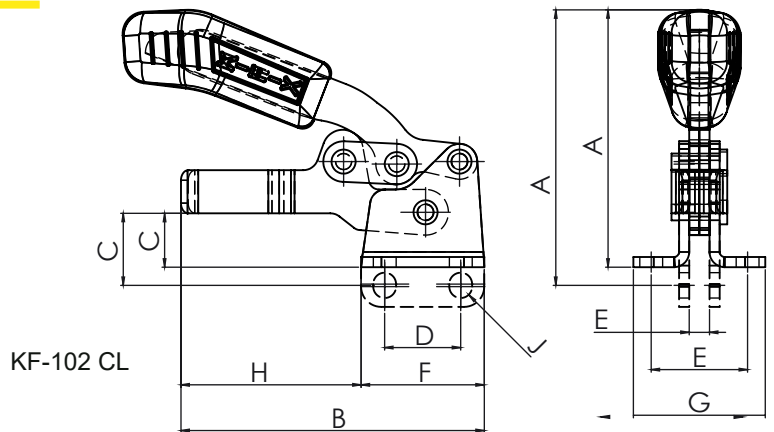

KF-102 CL

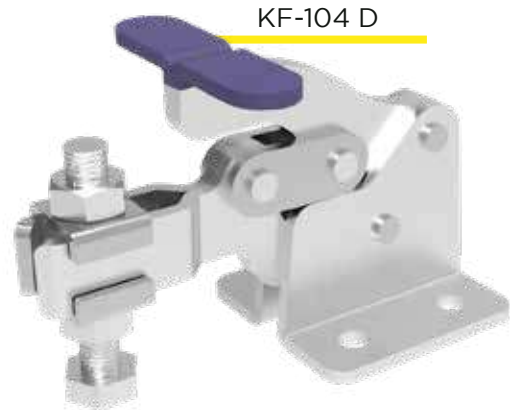

KF-104 D

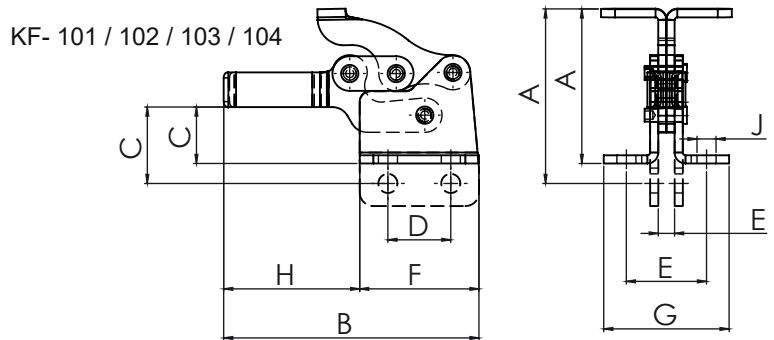

KF- 101 / 102 / 103 / 104

**BASES**

D - Flanged Base  
R - Straight Base

**HASTES**

CL - Long Handle

TR - With Toggle -  
Lock Plus

**PIES**

D - Doblado  
R - Recto

**BRAZO**

CL - Cable largo

TR - Bloqueo

REFERENCE	RETENTION FORCE KGF (LBF)	A (IN)	B (IN)	C (IN)	D (IN)	E (IN)	F (IN)	G (IN)	H (IN)	J (IN)	SPINDLE	OPENING ANGLE	WEIGHT KG (LB)
Referencia	Fuerza Retención Kgf (lbf)										Tornillo	Angulo de Apertura	Peso
KF-102 D	50 (110)	38 (1,50)	60 (2,36)	11 (0,43)	15 (0,59)	19 (0,75)	24 (0,94)	26 (1,02)	36 (1,42)	4,5 (0,18)	M6	75	0,075 (0,165)
KF-102 R	50 (110)	42 (1,65)	60 (2,36)	14 (0,55)	15 (0,59)	4 (0,16)	24 (0,94)	-	36 (1,42)	4,5 (0,18)	M6	75	0,075 (0,165)
KF-102 D CL	50 (110)	54 (2,13)	80 (3,15)	11 (0,43)	15 (0,59)	19 (0,75)	24 (0,94)	26 (1,02)	36 (1,42)	4,5 (0,18)	M6	75	0,085 (0,187)
KF-102 R CL	50 (110)	58 (2,28)	80 (3,15)	14 (0,55)	15 (0,59)	4 (0,16)	24 (0,94)	-	36 (1,42)	4,5 (0,18)	M6	75	0,085 (0,187)
KF-101 D	65 (143)	40 (1,57)	61 (2,40)	12,2 (0,48)	13,5 (0,53)	16 (0,63)	26 (1,02)	26 (1,02)	35 (1,38)	4,5 (0,18)	M6	75	0,075 (0,165)
KF-101 R	65 (143)	43 (1,69)	61 (2,40)	15 (0,59)	13,5 (0,53)	4 (0,16)	26 (1,02)	-	35 (1,38)	4,5 (0,18)	M6	75	0,075 (0,165)
KF-103 D	75 (165)	57 (2,24)	94 (3,70)	21 (0,83)	23 (0,91)	29 (1,14)	44 (1,73)	46 (1,81)	50 (1,97)	7,0 (0,28)	M6	85	0,260 (0,572)
KF-103 D TR	75 (165)	57 (2,24)	94 (3,70)	21 (0,83)	23 (0,91)	29 (1,14)	44 (1,73)	46 (1,81)	50 (1,97)	7,0 (0,28)	M6	85	0,275 (0,605)
KF-103 R	75 (165)	64 (2,52)	94 (3,70)	28 (1,10)	23 (0,91)	6 (0,24)	44 (1,73)	-	50 (1,97)	7,0 (0,28)	M6	85	0,260 (0,572)
KF-104 D	340 (748)	85,6 (3,37)	131,8 (5,19)	31,3 (1,23)	35 (1,38)	38,1 (1,50)	64 (2,52)	62,7 (2,47)	67,8 (2,67)	8,5 (0,33)	M6	90	0,670 (1,474)
KF-104 DS TR	340 (748)	85,6 (3,37)	131,8 (5,19)	31,3 (1,23)	35 (1,38)	38,1 (1,50)	64 (2,52)	62,7 (2,47)	48 (1,88)	8,5 (0,33)	M10	90	0,721 (1,589)
KF-104 R	340 (748)	95,9 (3,78)	131,8 (5,19)	41,6 (1,64)	35 (1,38)	7,5 (0,30)	64 (2,52)	-	67,8 (2,67)	8,5 (0,33)	M10	90	0,670 (1,474)



# HORIZONTAL HOLD-DOWN TOGGLE CLAMP PRENSA RÁPIDA HORIZONTAL

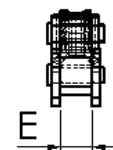
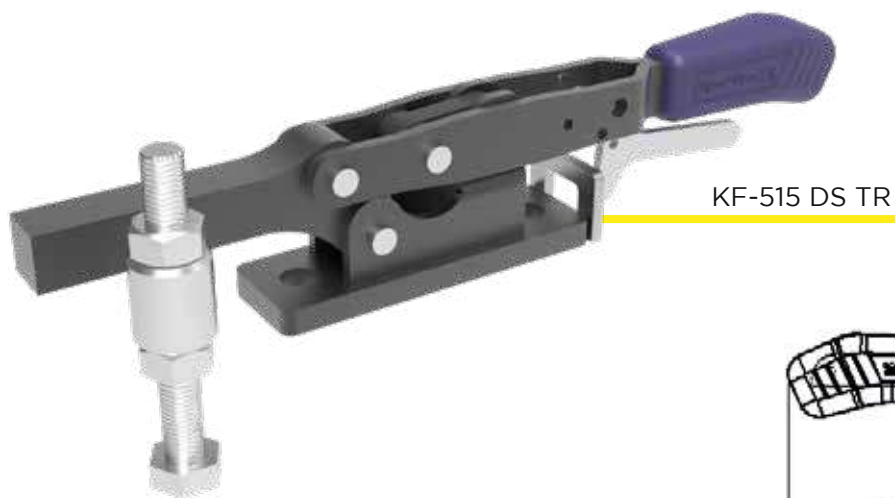
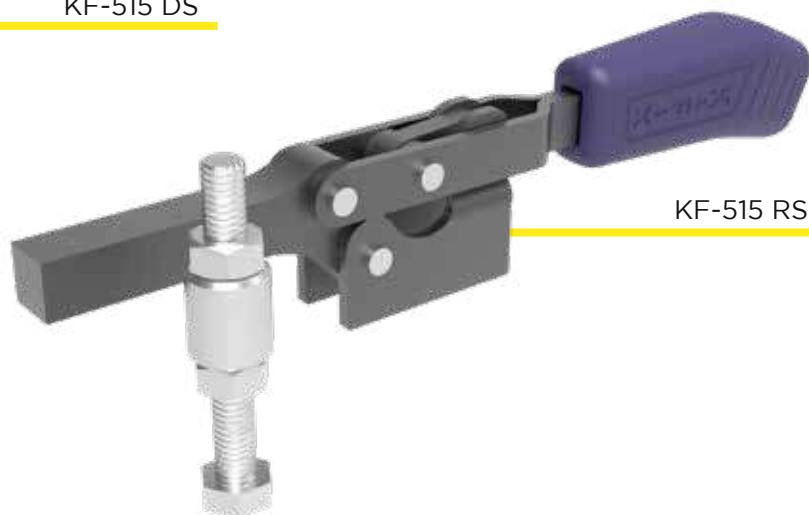
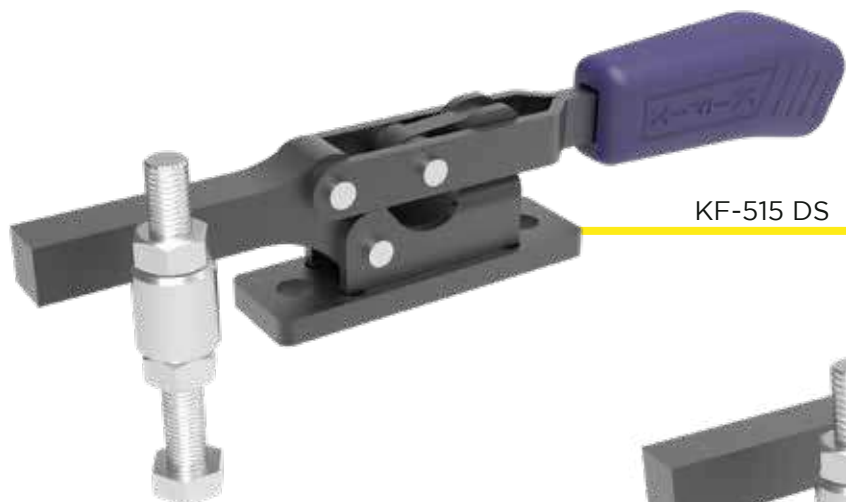

KF-515 RS

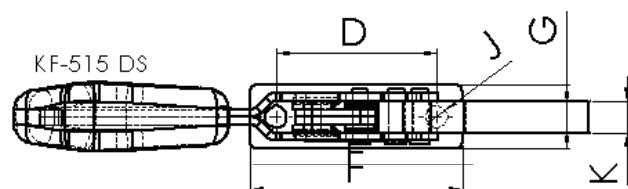
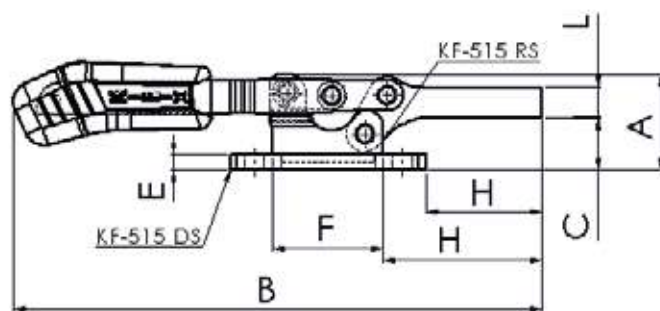

**BASES**  
D - Flanged Base  
R - Straight Base

**BAR**  
S - Solid

**PIES**  
D - Doblado  
R - Recto

**BRAZO**  
S - Solido

REFERENCE	RETENTION FORCE KGf (LBF)	A (IN)	B (IN)	C (IN)	D (IN)	E (IN)	F (IN)	G (IN)	H (IN)	J (IN)	K (IN)	L (IN)	SPINDLE	OPENING ANGLE	WEIGHT KG (LB)
Referencia	Fuerza Retención Kg (Lbf)												Tornillo	Angulo de Apertura	Peso
KF-515 DS	360 (792)	40,8 (1,61)	228 (8,98)	22,3 (0,88)	63,5 (2,50)	6,35 (0,25)	84 (3,31)	25,4 (1,00)	50 (1,97)	8,5 (0,33)	12,7 (0,50)	12,7 (0,50)	M8	85	0,520 (1,144)
KF-515 DS TR	360 (792)	40,8 (1,61)	228 (8,98)	22,3 (0,88)	63,5 (2,50)	6,35 (0,25)	84 (3,31)	25,4 (1,00)	50 (1,97)	8,5 (0,33)	12,7 (0,50)	12,7 (0,50)	M8	85	0,520 (1,144)
KF-515 RS	360 (792)	40,8 (1,61)	228 (8,98)	22,3 (0,88)	-	12,7 (0,50)	47,8 (1,88)	-	68,2 (2,69)	-	12,7 (0,50)	12,7 (0,50)	M8	85	0,450 (0,990)

# REINFORCED HORIZONTAL CLAMPS PRENSA HORIZONTALES REFORZADAS

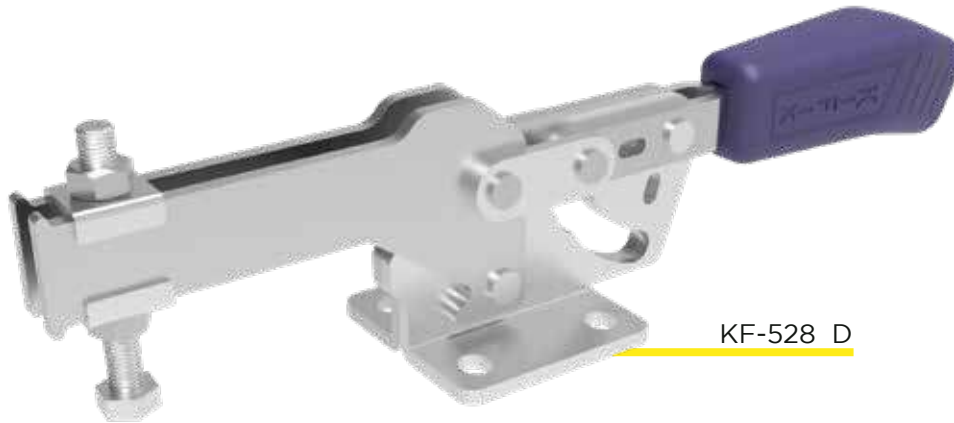

KF-528 D

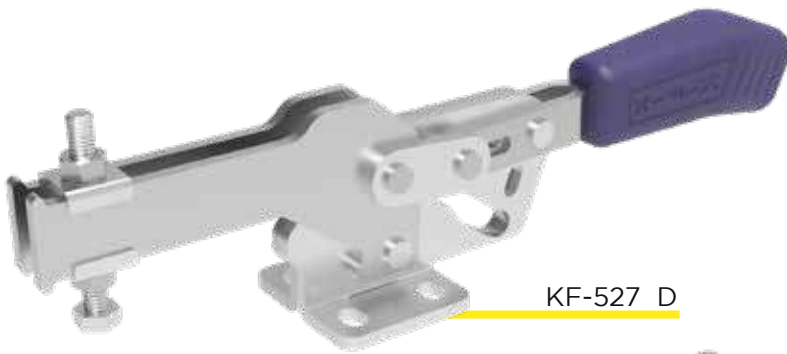

KF-527 D

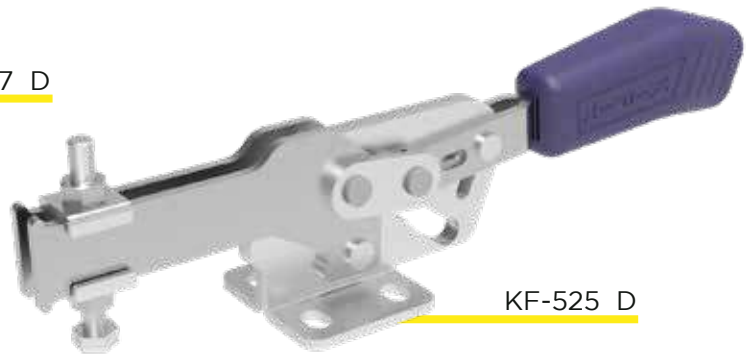

KF-525 D

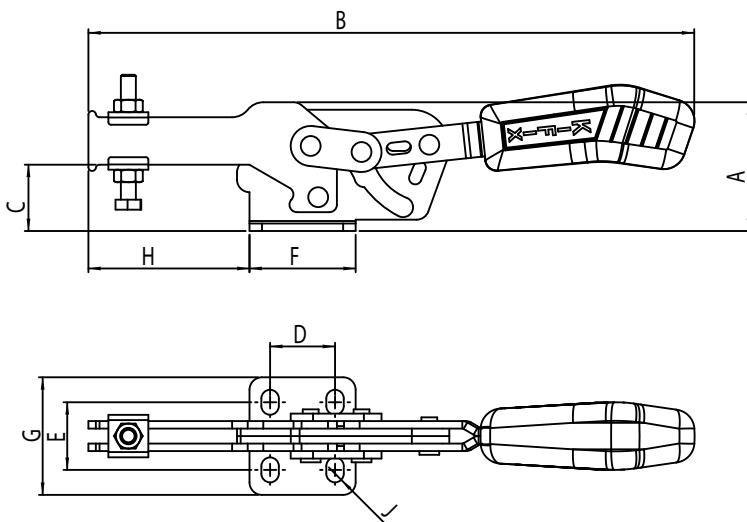

**BASES**  
D - Flanged Base

**PIES**  
D - Doblado

REFERENCE	RETENTION FORCE KGf (LBF)	A (IN)	B (IN)	C (IN)	D (IN)	E (IN)	F (IN)	G (IN)	H (IN)	J (IN)	SPINDLE	OPENING ANGLE	WEIGHT KG (LB)
Referencia	Fuerza Retención Kg (lbf)										Tornillo	Angulo de Apertura	Peso
KF-524 D	130 (286,60)	34,4 (1,35)	167 (6,57)	19 (0,74)	13,5 (0,53)	17 (0,66)	25,4 (1,00)	27 (1,06)	1,65 (0,06)	4,5 (1,77)	M6	69	0,17 (0,37)
KF-525 D	230 (507,06)	51,5 (2,02)	242 (9,52)	26 (1,02)	26 (1,02)	27 (1,06)	42,5 (1,67)	47 (1,85)	64,5 (2,53)	7 (0,27)	M6	69	0,47 (1,03)
KF-527 D	230 (507,06)	60 (2,36)	258 (10,15)	35 (1,37)	26 (1,02)	29,9 (1,17)	42,5 (1,67)	46,9 (1,84)	72 (2,83)	7 (0,27)	M6	69	0,60 (1,32)
KF-528 D	240 (529,10)	70,8 (2,78)	305 (12,00)	41 (1,61)	42 (1,65)	41 (1,61)	62 (2,44)	63,5 (2,50)	93 (3,66)	8,5 (0,33)	M8	69	1,03 (2,27)

# PULL ACTION LATCH CLAMP PRENSA RÁPIDA DE GANCHO

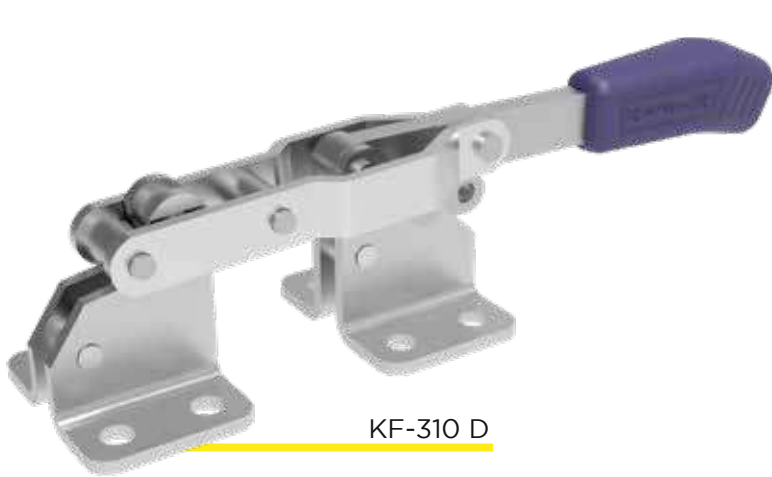

KF-310 D



KF-320

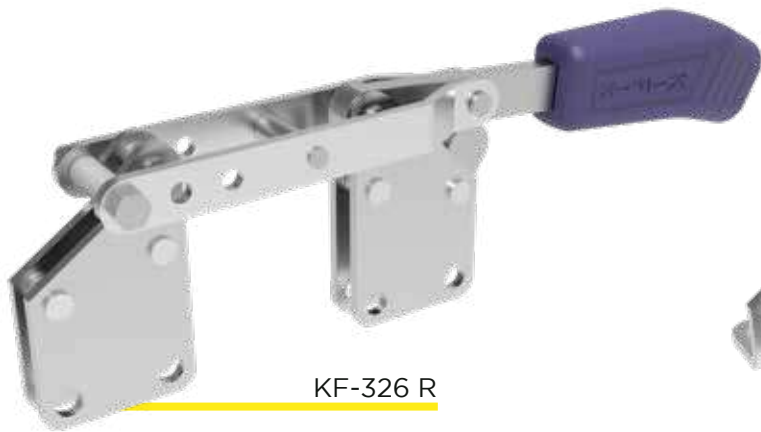

KF-326 R

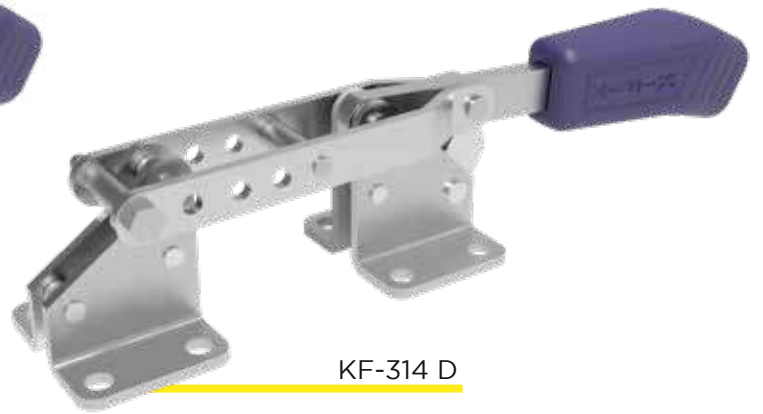

KF-314 D

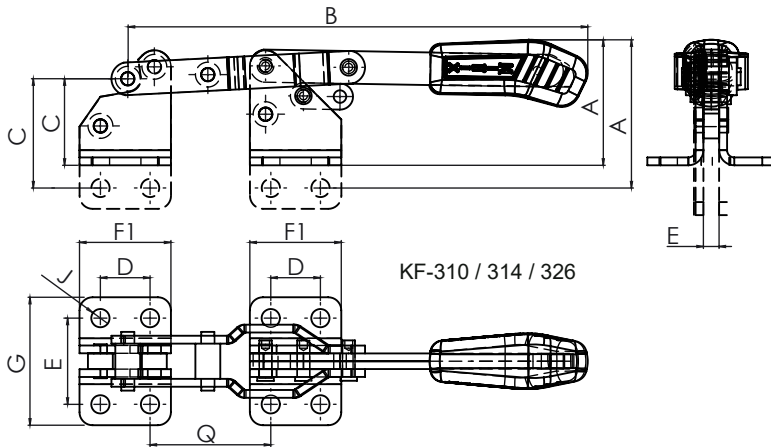

KF-310 / 314 / 326

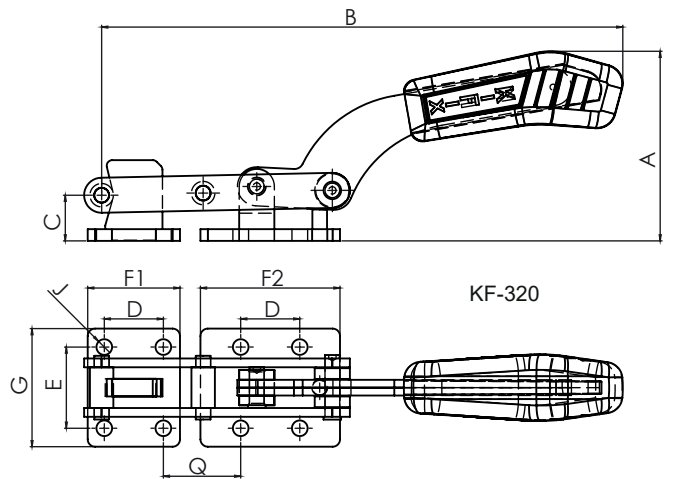

KF-320

**BASES**  
D - Flanged Base  
R - Straight Base

**PIES**  
D - Doblado  
R - Recto

REFERENCE	RETENTION FORCE KGf (LBF)	A (IN)	B (IN)	C (IN)	D (IN)	E (IN)	F1 (IN)	F2 (IN)	G (IN)	J (IN)	Q (IN)	HOOK GOUGE	WEIGHT KG (LB)
Referencia	Fuerza Retención Kg (lb)											Espesor Gancho	Peso
KF-310 D	170 (374)	48 (1,89)	176 (6,93)	33 (1,30)	19 (0,75)	33 (1,30)	35 (1,38)	-	49 (1,93)	7,0 (0,28)	46 (1,81)	M6	0,350 (0,770)
KF-310 R	170 (374)	57 (2,24)	176 (6,93)	42 (1,65)	19 (0,75)	6 (0,24)	35 (1,38)	-	-	7,0 (0,28)	46 (1,81)	M6	0,350 (0,770)
KF-314 D	340 (748)	60 (2,36)	263 (10,35)	47 (1,85)	32 (1,26)	44 (1,73)	48 (1,89)	-	60 (2,36)	8,5 (0,33)	74 (2,91)	M6	0,830 (1,826)
KF-314 R	340 (748)	73 (2,87)	263 (10,35)	60 (2,36)	32 (1,26)	8 (0,31)	48 (1,89)	-	-	8,5 (0,33)	74 (2,91)	M6	0,830 (1,826)
KF-326 D	340 (748)	60 (2,36)	263 (10,35)	47 (1,85)	32 (1,26)	44 (1,73)	48 (1,89)	-	60 (2,36)	8,5 (0,33)	74 (2,91)	M6	0,830 (1,826)
KF-326 R	340 (748)	73 (2,87)	263 (10,35)	60 (2,36)	32 (1,26)	8 (0,31)	48 (1,89)	-	-	8,5 (0,33)	74 (2,91)	M6	0,830 (1,826)
KF-320	800 (1760)	103 (4,06)	282 (11,10)	25 (0,98)	32 (1,26)	44 (1,73)	50 (1,97)	76 (2,99)	64 (2,52)	8,5 (0,33)	42 (1,65)	M6	1,250 (2,750)

# PULL ACTION LATCH CLAMP PRENSA RÁPIDA DE GANCHO



KF-133 D TR

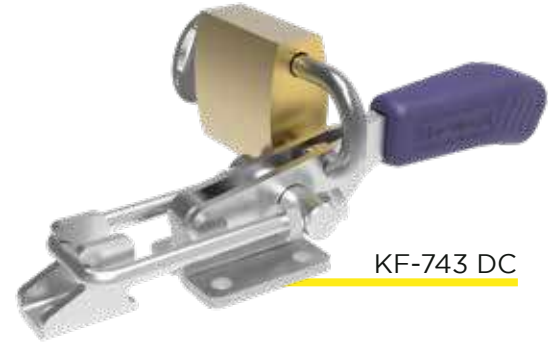

KF-743 DC

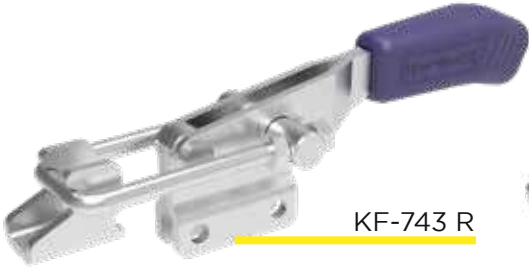

KF-743 R



KF-943 DV



KF-943 DL

**PADLOCK WILL NOT COME WITH THE CLAMP**  
**CANDADO NO ACOMPAÑA LA GRAPA**

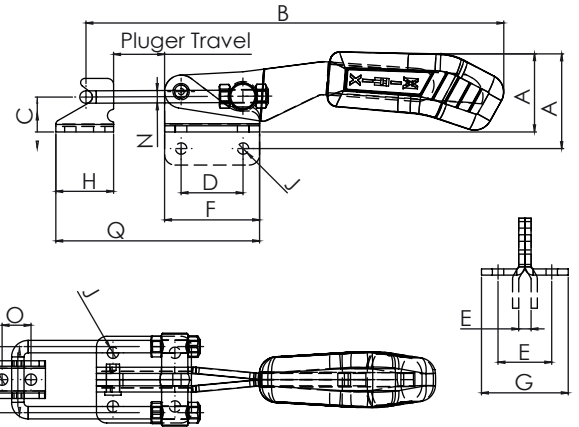

**BASES**  
 D - Flanged Base  
 R - Straight Base

**BAR**  
 H - Bar  
 L - Long U-Bar

**CABO**  
 V - Vertical

TR - With Toogle - Lock Plus  
 C - Option of padlock

**PIES**  
 D - Doblado  
 R - Recto

**BRAZO**  
 H - Brazo  
 L - Largo

**CABLE**  
 V - Vertical

TR - Bloqueo  
 C - Opción de candado

REFERENCE	RETENTION FORCE KGF (LBF)	PLUNGER TRAVEL (IN)	A (IN)	B MÍN (IN)	B MÁX (IN)	C (IN)	D (IN)	E (IN)	F (IN)	G (IN)	H (IN)	J (IN)	L (IN)	M (IN)	N (IN)	O (IN)	Q MÍN (IN)	Q MÁX (IN)	HOOK GOUGE	WEIGHT KG (LB)
Referencia	Fuerza Retención Kgf (Lbf)	Curso	A (IN)	B MÍN (IN)	B MÁX (IN)	C (IN)	D (IN)	E (IN)	F (IN)	G (IN)	H (IN)	J (IN)	L (IN)	M (IN)	N (IN)	O (IN)	Q MÍN (IN)	Q MÁX (IN)	Espesor Gancho	Peso
KF-233 D	160 (352)	32 (1.26)	31 (1.22)	112 (4.41)	126 (4.96)	10 (0.39)	16 (0.63)	19 (0.75)	26 (1.02)	28 (1.10)	20 (0.79)	4.3 (0.17)	13 (0.51)	19 (0.75)	4 (0.16)	10 (0.39)	46 (1.81)	60 (2.36)	M4	0.120 (0.264)
KF-233 R	160 (352)	32 (1.26)	40 (1.57)	112 (4.41)	126 (4.96)	10 (0.39)	16 (0.63)	4 (0.16)	26 (1.02)	-	20 (0.79)	4.3 (0.17)	13 (0.51)	19 (0.75)	4 (0.16)	10 (0.39)	46 (1.81)	60 (2.36)	M4	0.120 (0.264)
KF-233 DTR	160 (352)	48 (1.89)	37 (1.46)	122 (4.80)	136 (5.35)	10 (0.39)	16 (0.63)	19 (0.75)	26 (1.02)	28 (1.10)	20 (0.79)	4.3 (0.17)	13 (0.51)	19 (0.75)	4 (0.16)	10 (0.39)	46 (1.81)	60 (2.36)	M4	0.140 (0.308)
KF-643 D	200 (440)	48 (1.89)	56 (2.20)	139 (5.47)	155 (6.10)	14 (0.55)	24 (0.94)	22 (0.87)	36 (1.42)	33 (1.30)	23 (0.91)	5.5 (0.22)	16 (0.63)	25 (0.98)	5 (0.20)	11 (0.43)	59 (2.32)	75 (2.95)	M5	0.230 (0.506)
KF-643 DV	200 (440)	48 (1.89)	121 (4.76)	73 (2.87)	89 (3.50)	14 (0.55)	24 (0.94)	22 (0.87)	36 (1.42)	33 (1.30)	23 (0.91)	5.5 (0.22)	16 (0.63)	25 (0.98)	5 (0.20)	11 (0.43)	59 (2.32)	75 (2.95)	M5	0.215 (0.473)
KF-643 DL	200 (440)	48 (1.89)	56 (2.20)	139 (5.47)	210 (8.27)	14 (0.55)	24 (0.94)	22 (0.87)	36 (1.42)	33 (1.30)	23 (0.91)	5.5 (0.22)	16 (0.63)	25 (0.98)	5 (0.20)	11 (0.43)	59 (2.32)	130 (5.12)	M5	0.240 (0.528)
KF-643 R	200 (440)	48 (1.89)	62 (2.44)	139 (5.47)	155 (6.10)	14 (0.55)	24 (0.94)	6 (0.24)	36 (1.42)	-	23 (0.91)	5.5 (0.22)	16 (0.63)	25 (0.98)	5 (0.20)	11 (0.43)	59 (2.32)	75 (2.95)	M5	0.230 (0.506)
KF-643 RL	200 (440)	48 (1.89)	62 (2.44)	139 (5.47)	210 (8.27)	14 (0.55)	24 (0.94)	6 (0.24)	36 (1.42)	-	23 (0.91)	5.5 (0.22)	16 (0.63)	25 (0.98)	5 (0.20)	11 (0.43)	59 (2.32)	130 (5.12)	M5	0.240 (0.528)
KF-643 DTR	200 (440)	48 (1.89)	59 (2.32)	139 (5.47)	155 (6.10)	14 (0.55)	24 (0.94)	22 (0.87)	36 (1.42)	33 (1.30)	23 (0.91)	5.5 (0.22)	16 (0.63)	25 (0.98)	5 (0.20)	11 (0.43)	74 (2.91)	90 (3.54)	M5	0.290 (0.638)
KF-743 D	200 (440)	48 (1.89)	37 (1.46)	137 (5.39)	153 (6.02)	14 (0.55)	24 (0.94)	22 (0.87)	36 (1.42)	33 (1.30)	23 (0.91)	5.5 (0.22)	16 (0.63)	25 (0.98)	5 (0.20)	11 (0.43)	59 (2.32)	75 (2.95)	M5	0.210 (0.462)
KF-743 DL	200 (440)	48 (1.89)	37 (1.46)	137 (5.39)	208 (8.19)	14 (0.55)	24 (0.94)	22 (0.87)	36 (1.42)	33 (1.30)	23 (0.91)	5.5 (0.22)	16 (0.63)	25 (0.98)	5 (0.20)	11 (0.43)	59 (2.32)	130 (5.12)	M5	0.220 (0.484)
KF-743 DC	200 (440)	48 (1.89)	37 (1.46)	137 (5.39)	153 (6.02)	14 (0.55)	24 (0.94)	22 (0.87)	36 (1.42)	33 (1.30)	23 (0.91)	5.5 (0.22)	16 (0.63)	25 (0.98)	5 (0.20)	11 (0.43)	59 (2.32)	75 (2.95)	M5	0.200 (0.440)
KF-743 R	200 (440)	48 (1.89)	42 (1.65)	137 (5.39)	153 (6.02)	14 (0.55)	24 (0.94)	6 (0.24)	36 (1.42)	-	23 (0.91)	5.5 (0.22)	16 (0.63)	25 (0.98)	5 (0.20)	11 (0.43)	59 (2.32)	75 (2.95)	M5	0.210 (0.462)
KF-743 RL	200 (440)	48 (1.89)	42 (1.65)	137 (5.39)	208 (8.19)	14 (0.55)	24 (0.94)	6 (0.24)	36 (1.42)	-	23 (0.91)	5.5 (0.22)	16 (0.63)	25 (0.98)	5 (0.20)	11 (0.43)	59 (2.32)	130 (5.12)	M5	0.220 (0.484)
KF-133 D	300 (660)	60 (2.36)	54 (2.13)	196 (7.72)	223 (8.78)	13 (0.51)	19 (0.75)	32 (1.26)	40 (1.57)	44 (1.73)	28 (1.10)	7.0 (0.28)	22.5 (0.89)	31 (1.22)	6 (0.24)	14 (0.55)	68 (2.68)	95 (3.74)	M6	0.440 (0.968)
KF-133 DTR	300 (660)	60 (2.36)	57 (2.24)	196 (7.72)	223 (8.78)	13 (0.51)	19 (0.75)	32 (1.26)	40 (1.57)	44 (1.73)	28 (1.10)	7.0 (0.28)	22.5 (0.89)	31 (1.22)	6 (0.24)	14 (0.55)	68 (2.68)	95 (3.74)	M6	0.530 (1.166)
KF-843 D	340 (748)	60 (2.36)	38 (1.50)	177 (6.97)	202 (7.95)	17 (0.67)	30 (1.18)	26 (1.02)	46 (1.81)	42 (1.65)	28 (1.10)	5.5 (0.22)	19 (0.75)	32 (1.26)	6 (0.24)	14 (0.55)	74 (2.91)	99 (3.90)	M6	0.360 (0.792)
KF-843 DL	340 (748)	126 (4.96)	37 (1.45)	177 (6.97)	290 (11.41)	17 (0.67)	30 (1.18)	26 (1.02)	46 (1.81)	42 (1.65)	28 (1.10)	5.5 (0.22)	18 (0.70)	31 (1.22)	6 (0.24)	30 (1.18)	74 (2.91)	99 (3.90)	M6	0.400 (0.881)
KF-843 DC	340 (748)	60 (2.36)	38 (1.50)	177 (6.97)	202 (7.95)	17 (0.67)	30 (1.18)	26 (1.02)	46 (1.81)	42 (1.65)	28 (1.10)	5.5 (0.22)	19 (0.75)	32 (1.26)	6 (0.24)	14 (0.55)	74 (2.91)	99 (3.90)	M6	0.400 (0.880)
KF-843 R	340 (748)	60 (2.36)	55 (2.17)	177 (6.97)	202 (7.95)	17 (0.67)	30 (1.18)	6 (0.24)	46 (1.81)	-	28 (1.10)	5.5 (0.22)	19 (0.75)	32 (1.26)	6 (0.24)	14 (0.55)	74 (2.91)	99 (3.90)	M6	0.360 (0.792)
KF-843 DTR	340 (748)	60 (2.36)	40 (1.57)	169 (6.65)	194 (7.64)	17 (0.67)	30 (1.18)	26 (1.02)	46 (1.81)	42 (1.65)	28 (1.10)	5.5 (0.22)	19 (0.75)	32 (1.26)	6 (0.24)	14 (0.55)	74 (2.91)	99 (3.90)	M6	0.420 (0.924)
KF-943 D	680 (1496)	80 (3.15)	60 (2.36)	241 (9.49)	286 (11.26)	21 (0.83)	40 (1.57)	36 (1.42)	60 (2.36)	56 (2.20)	38 (1.50)	7.0 (0.28)	26 (1.02)	40 (1.57)	8 (0.31)	19 (0.75)	98 (3.86)	143 (5.63)	M8	0.790 (1.738)
KF-943 DC	680 (1496)	80 (3.15)	60 (2.36)	241 (9.49)	286 (11.26)	21 (0.83)	40 (1.57)	36 (1.42)	60 (2.36)	56 (2.20)	38 (1.50)	7.0 (0.28)	26 (1.02)	40 (1.57)	8 (0.31)	19 (0.75)	98 (3.86)	143 (5.63)	M8	0.810 (1.782)
KF-943 DL	680 (1496)	80 (3.15)	60 (2.36)	241 (9.49)	361 (14.21)	21 (0.83)	40 (1.57)	36 (1.42)	60 (2.36)	56 (2.20)	38 (1.50)	7.0 (0.28)	26 (1.02)	40 (1.57)	8 (0.31)	19 (0.75)	98 (3.86)	218 (8.58)	M8	0.850 (1.870)
KF-943 R	680 (1496)	80 (3.15)	72 (2.83)	241 (9.49)	286 (11.26)	21 (0.83)	40 (1.57)	8 (0.31)	60 (2.36)	-	38 (1.50)	7.0 (0.28)	26 (1.02)	40 (1.57)	8 (0.31)	19 (0.75)	98 (3.86)	143 (5.63)	M8	0.790 (1.738)
KF-943 RL	680 (1496)	80 (3.15)	72 (2.83)	241 (9.49)	361 (14.21)	21 (0.83)	40 (1.57)	8 (0.31)	60 (2.36)	-	38 (1.50)	7.0 (0.28)	26 (1.02)	40 (1.57)	8 (0.31)	19 (0.75)	98 (3.86)	218 (8.58)	M8	0.850 (1.870)
KF-943 DTR	680 (1496)	80 (3.15)	60 (2.36)	241 (9.49)	286 (11.26)	21 (0.83)	40 (1.57)	36 (1.42)	60 (2.36)	56 (2.20)	38 (1.50)	7.0 (0.28)	26 (1.02)	40 (1.57)	8 (0.31)	19 (0.75)	98 (3.86)	143 (5.63)	M8	0.830 (1.826)
KF-143 D	890 (1958)	80 (3.15)	73.4 (2.89)	207.4 (8.17)	225.4 (8.87)	21.3 (0.84)	41.3 (1.63)	38.1 (1.50)	60.5 (2.38)	53.8 (2.12)	38 (1.50)	8.5 (0.33)	25.5 (1.00)	40 (1.57)	8 (0.31)	19 (0.75)	98.6 (3.88)	116.6 (4.59)	M8	0.720 (1.584)
KF-143 DTR	890 (1958)	80 (3.15)	73.4 (2.89)	207.4 (8.17)	225.4 (8.87)	21.3 (0.84)	41.3 (1.63)	38.1 (1.50)	60.5 (2.38)	53.8 (2.12)	38 (1.50)	8.5 (0.33)	25.5 (1.00)	40 (1.57)	8 (0.31)	19 (0.75)	98.6 (3.88)	116.6 (4.59)	M8	0.770 (1.694)
KF-943 SUV	1200 (2645)	80 (3.15)	183 (7.20)	98 (3.85)	148 (5.82)	21 (0.82)	40 (1.57)	36 (1.42)	60 (2.36)	56 (2.20)	38 (1.50)	7.0 (0.28)	26 (1.02)	40 (1.57)	8 (0.31)	19 (0.74)	93 (3.66)	143 (5.62)	M8	0.780 (1.71)
KF-943 SU H150	1400 (3086)	80 (3.15)	60 (2.36)	254 (10)	299 (11.77)	16 (0.59)	40 (1.57)	36 (1.42)	60 (2.36)	56 (2.20)	60 (2.36)	7.0 (0.28)	56 (2.20)	44 (1.73)	10 (0.39)	36 (1.41)	13 (0.51)	58 (2.28)	M10	1.370 (3.020)
KF-943 SU H200	1400 (3086)	80 (3.15)	60 (2.36)	304 (11.96)	369 (14.52)	15 (0.59)	40 (1.57)	36 (1.42)	60 (2.36)	56 (2.20)	38 (1.50)	7.0 (0.28)	9.5 (0.37)	44 (1.73)	10 (0.39)	-	161 (6.33)	226 (8.89)	M10	1.280 (2.821)

# PULL ACTION LATCH CLAMP PRENSA RÁPIDA DE GANCHO

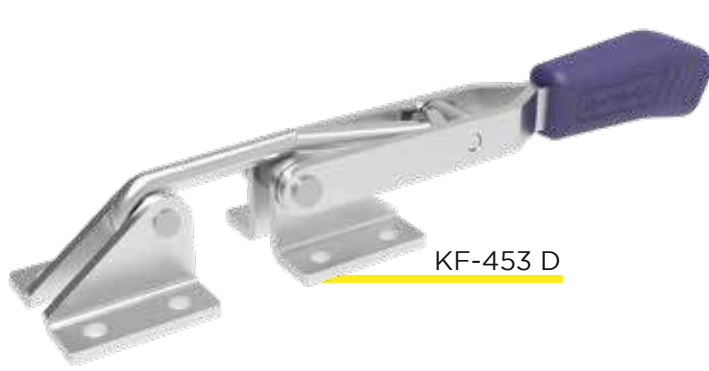

KF-453 D

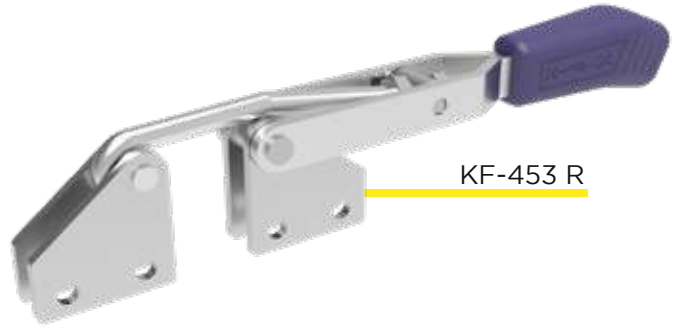

KF-453 R

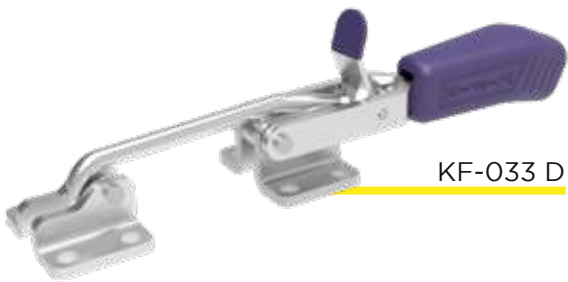

KF-033 D

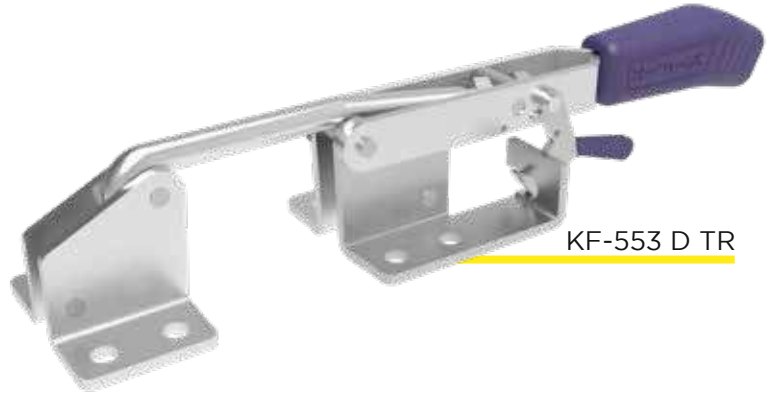

KF-553 D TR

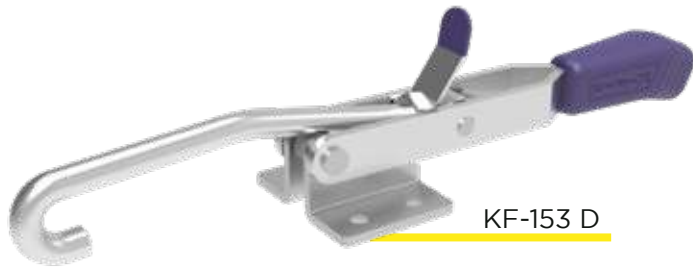

KF-153 D

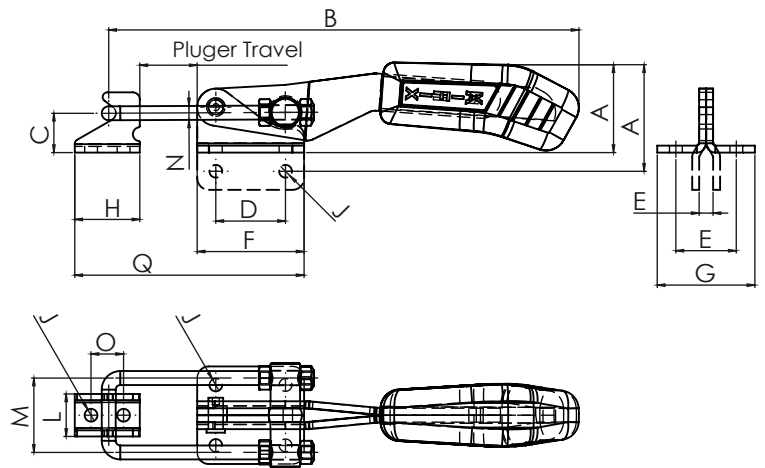

**BASES**

D - Flanged Base  
R - Straight Base

**BAR**

L - Long U-Bar

TR - With Toogle  
- Lock Plus

**PIES**

D - Doblado  
R - Recto

**BRAZO**

L - Largo

TR - Bloqueo

REFERENCE	RETENTION FORCE KGf (LBF)	PLUNGER TRAVEL (IN)	A (IN)	B (IN)	C (IN)	D (IN)	E (IN)	F (IN)	G (IN)	J (IN)	N (IN)	Q (IN)	R (IN)	HOOK GOUGE	WEIGHT KG (LB)
Referencia	Fuerza Retención Kgf (lbf)	Curso												Espesor Gancho	Peso
KF-033 D	90 (198)	35.5 (1.39)	26 (1.02)	163 (6.42)	12 (0.47)	16 (0.63)	25.4 (1.00)	25.4 (1.00)	34 (1.34)	5.5 (0.22)	5 (0.20)	46 (1.81)	8 (0.31)	M5	0.160 (0.352)
KF-033 DL	65 (143)	122 (4.80)	30 (1.18)	240 (9.45)	12 (0.47)	16 (0.63)	25.4 (1.00)	25.4 (1.00)	34 (1.34)	5.5 (0.22)	5 (0.20)	124 (4.88)	8 (0.31)	M5	0.180 (0.396)
KF-353 D	120 (264)	15.2 (0.59)	35 (1.38)	215 (8.46)	18 (0.71)	25.4 (1.00)	25 (0.98)	35 (1.38)	38 (1.50)	5.5 (0.22)	6 (0.24)	40 (1.57)	8 (0.31)	M6	0.300 (0.660)
KF-353 R	120 (264)	30.2 (1.18)	39 (1.54)	215 (8.46)	23 (0.91)	25.4 (1.00)	6.4 (0.25)	35 (1.38)	-	5.5 (0.22)	6 (0.24)	40 (1.57)	8 (0.31)	M6	0.300 (0.660)
KF-353 DTR	120 (264)	29.2 (1.14)	35 (1.38)	215 (8.46)	18 (0.71)	25.4 (1.00)	25 (0.98)	35 (1.38)	38 (1.50)	5.5 (0.22)	6 (0.24)	40 (1.57)	8 (0.31)	M6	0.310 (0.682)
KF-153 D	170 (374)	58 (2.28)	35 (1.38)	241 (9.49)	19 (0.75)	19.1 (0.75)	35 (1.38)	38.1 (1.50)	49.3 (1.94)	5.5 (0.22)	8 (0.31)	-	5 (0.20)	M8	0.330 (0.726)
KF-153 DTR	170 (374)	58 (2.28)	35 (1.38)	251 (9.88)	19 (0.75)	19.1 (0.75)	35 (1.38)	38.1 (1.50)	49.3 (1.94)	5.5 (0.22)	8 (0.31)	-	5 (0.20)	M8	0.370 (0.814)
KF-153 R	170 (374)	58 (2.28)	44.2 (1.74)	241 (9.49)	28 (1.10)	19.1 (0.75)	8 (0.31)	38.1 (1.50)	-	5.5 (0.22)	8 (0.31)	-	5 (0.20)	M8	0.330 (0.726)
KF-453 D	340 (748)	28 (1.10)	40 (1.57)	248 (9.76)	25 (0.98)	25.4 (1.00)	36 (1.42)	45 (1.77)	51 (2.01)	7.0 (0.28)	8 (0.31)	44 (1.73)	10 (0.39)	M8	0.550 (1.210)
KF-453 R	340 (748)	28 (1.10)	48 (1.89)	248 (9.76)	32 (1.26)	25.4 (1.00)	10 (0.39)	45 (1.77)	-	7.0 (0.28)	8 (0.31)	44 (1.73)	10 (0.39)	M8	0.550 (1.210)
KF-453 DTR	340 (748)	28 (1.10)	40 (1.57)	248 (9.76)	25 (0.98)	25.4 (1.00)	36 (1.42)	45 (1.77)	51 (2.01)	7.0 (0.28)	8 (0.31)	44 (1.73)	10 (0.39)	M8	0.570 (1.254)
KF-553 D	900 (1980)	76 (2.99)	72 (2.83)	367 (14.45)	51 (2.01)	28.5 (1.12)	60.5 (2.38)	54 (2.13)	85.5 (3.37)	10.6 (0.42)	12 (0.47)	90 (3.54)	10 (0.39)	M123	1.550 (3.410)
KF-553 R	900 (1980)	76 (2.99)	88 (3.46)	367 (14.45)	67 (2.64)	28.5 (1.12)	13.5 (0.53)	54 (2.13)	-	10.6 (0.42)	12 (0.47)	90 (3.54)	10 (0.39)	M12	1.550 (3.410)
KF-553 D TR	900 (1980)	76 (2.99)	72 (2.83)	367 (14.45)	51 (2.01)	28.5 (1.12)	60.5 (2.38)	54 (2.13)	85.5 (3.37)	10.6 (0.42)	12 (0.47)	90 (3.54)	10 (0.39)	M12	1.650 (3.630)



# PULL ACTION LATCH CLAMP PRENSA RÁPIDA DE GANCHO

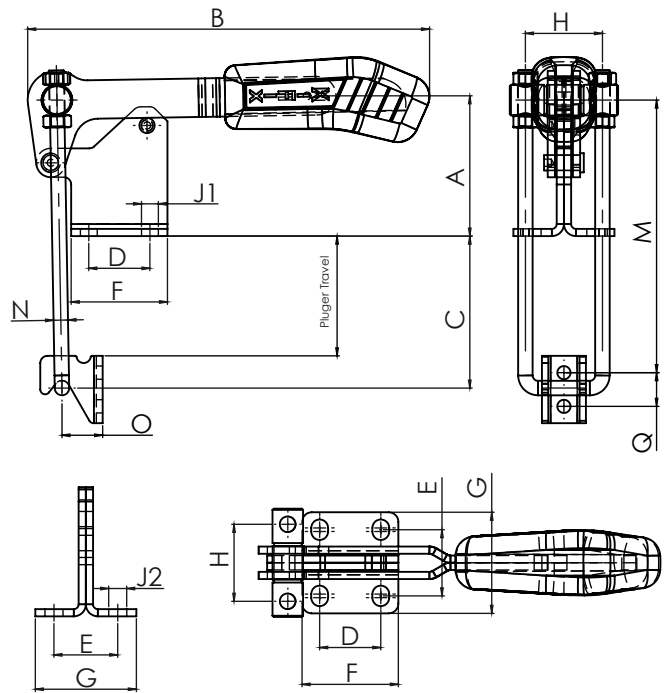

REFERENCE	RETENTION FORCE KGf (LBF)	PLUNGER TRAVEL (IN)	A (IN)	B (IN)	C MÁX (IN)	D (IN)	E (IN)	F (IN)	G (IN)	H (IN)	J1 (IN)	J2 (IN)	M MÍN (IN)	M MÁX (IN)	N (IN)	O (IN)	Q (IN)	HOOK GOUGE	WEIGHT KG (LB)
Referencia	Fuerza Retención Kgf (lbf)	Curso																Espesor Gancho	Peso
KF-063	200 (440)	40 (1.57)	41 (1.61)	129 (5.08)	72 (2.83)	24 (0.94)	26 (1.02)	35 (1.38)	37.5 (1.48)	25 (0.98)	6.0 (0.24)	8.0 (0.31)	45 (1.77)	105 (4.13)	5 (0.20)	13 (0.51)	11 (0.43)	M5	0.25 (0.550)
KF-063 TR	200 (440)	40 (1.57)	44 (1.73)	137 (5.39)	76 (2.99)	24 (0.94)	26 (1.02)	35 (1.38)	37.5 (1.48)	25 (0.98)	6.0 (0.24)	8.0 (0.31)	45 (1.77)	105 (4.13)	5 (0.20)	13 (0.51)	11 (0.43)	M5	0.32 (0.704)
KF-163	340 (748)	50 (1.97)	58 (2.28)	167 (6.57)	58 (2.28)	25 (1.00)	27.5 (1.08)	40 (1.57)	42 (1.65)	32 (1.26)	7.0 (0.28)	8.5 (0.33)	63 (2.48)	108 (4.25)	6 (0.24)	16 (0.63)	14 (0.55)	M6	0.43 (0.946)
KF-263	680 (1496)	80 (3.15)	52 (2.05)	196 (7.72)	78 (3.07)	32 (1.26)	33 (1.30)	50 (1.97)	55 (2.17)	38 (1.50)	8.5 (0.33)	12.0 (0.47)	67 (2.64)	127 (5.00)	8 (0.31)	22 (0.87)	19 (0.75)	M8	0.93 (2.046)
KF-263 TR	680 (1496)	80 (3.15)	55 (2.17)	211 (8.31)	74 (2.91)	32 (1.26)	33 (1.30)	50 (1.97)	55 (2.17)	38 (1.50)	8.5 (0.33)	12.0 (0.47)	71 (2.80)	127 (5.00)	8 (0.31)	22 (0.87)	19 (0.75)	M8	1.09 (2.398)

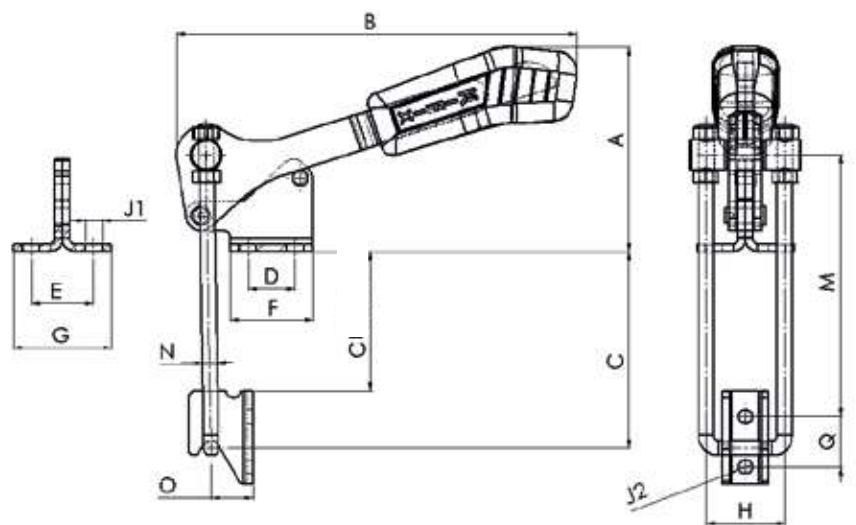

REFERENCE	RETENTION FORCE KGf (LBF)	PLUNGER TRAVEL (IN)	A (IN)	B (IN)	C MÁX (IN)	D (IN)	E (IN)	F (IN)	G (IN)	H (IN)	J1 (IN)	J2 (IN)	M MÍN (IN)	M MÁX (IN)	N (IN)	O (IN)	Q (IN)	HOOK GOUGE	WEIGHT KG (LB)
Referencia	Fuerza Retención Kgf (lbf)	Curso																Espesor Gancho	Peso
KF-423	220 (484)	32 (1.26)	77 (3.03)	122 (4.80)	83 (3.27)	12.7 (0.50)	22.4 (0.88)	25.4 (1.00)	35.1 (1.38)	25 (0.98)	5.1 (0.20)	4.3 (0.17)	35 (1.38)	102 (4.02)	5 (0.20)	14 (0.55)	14.2 (0.56)	M5	0.230 (0.506)
KF-423 D TR	220 (484)	32 (1.26)	77 (3.03)	122	83 (3.27)	12.7 (0.50)	22.4 (0.88)	25.4 (1.00)	35.1 (1.38)	25 (0.98)	5.1 (0.20)	4.3 (0.17)	35 (1.38)	102 (4.02)	5 (0.20)	14 (0.55)	14.2 (0.56)	M5	0.231 (0.509)
KF-433	450 (990)	32 (1.26)	84 (3.31)	162 (6.38)	80 (3.15)	19.1 (0.75)	25.4 (1.00)	33.3 (1.31)	39.6 (1.56)	32 (1.26)	7.1 (0.28)	5.6 (0.22)	50 (1.97)	107 (4.21)	6 (0.24)	17 (0.67)	20.6 (0.81)	M6	0.400 (0.880)
KF-443	890 (1958)	32 (1.26)	93 (3.66)	194 (7.64)	88 (3.46)	31.8 (1.25)	36.6 (1.44)	49.3 (1.94)	53.8 (2.12)	38 (1.50)	8.6 (0.34)	8.6 (0.34)	65 (2.56)	119 (4.69)	8 (0.31)	21 (0.83)	27 (1.06)	M8	0.890 (1.958)

# PULL ACTION LATCH CLAMP PRENSA RÁPIDA DE GANCHO



KF-473 D

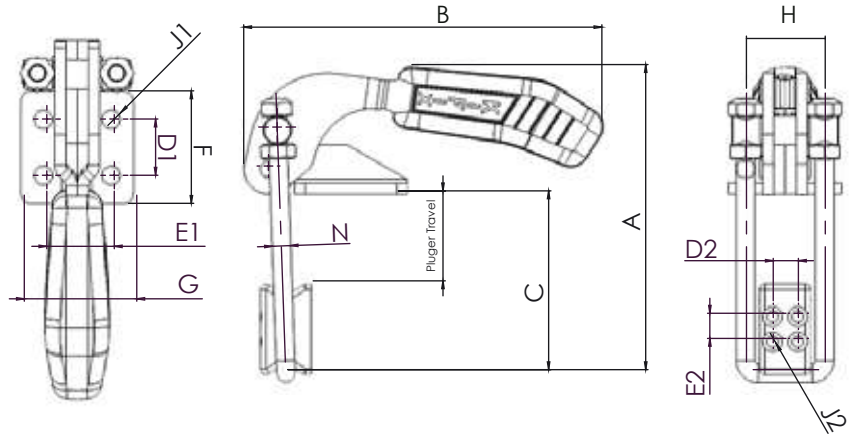

D - Flanged Base    D - Doblada

REFERENCE	RETENTION FORCE KGf (Lbf)	PLUNGER TRAVEL (IN)	A (IN)	B (IN)	C (IN)	D1 (IN)	D2 (IN)	E1 (IN)	E2 (IN)	F (IN)	G (IN)	H (IN)	J1 (IN)	J2 (IN)	N (IN)	HOOK GOUGE	WEIGHT KG (LB)
Referencia	Fuerza Retención Kg (lbf)	Curso														Espesor Gancho	Peso
KF-473 D	1800 (3960)	44 (1,73)	172 (6,77)	202 (7,95)	101 (3,98)	31,8 (1,25)	14,2 (0,56)	38,1 (1,50)	14,2 (0,56)	63,5 (2,50)	63,5 (2,50)	44,5 (1,75)	10,3 (0,41)	6,4 (0,25)	10 (0,39)	M10	1500 (3,300)



KF-330

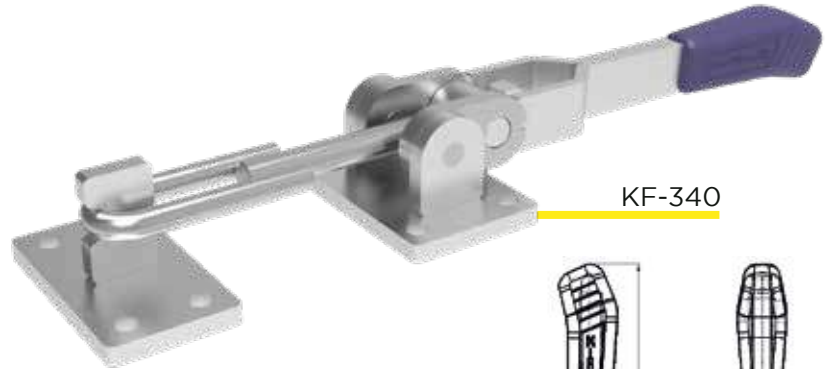

KF-340



KF-350

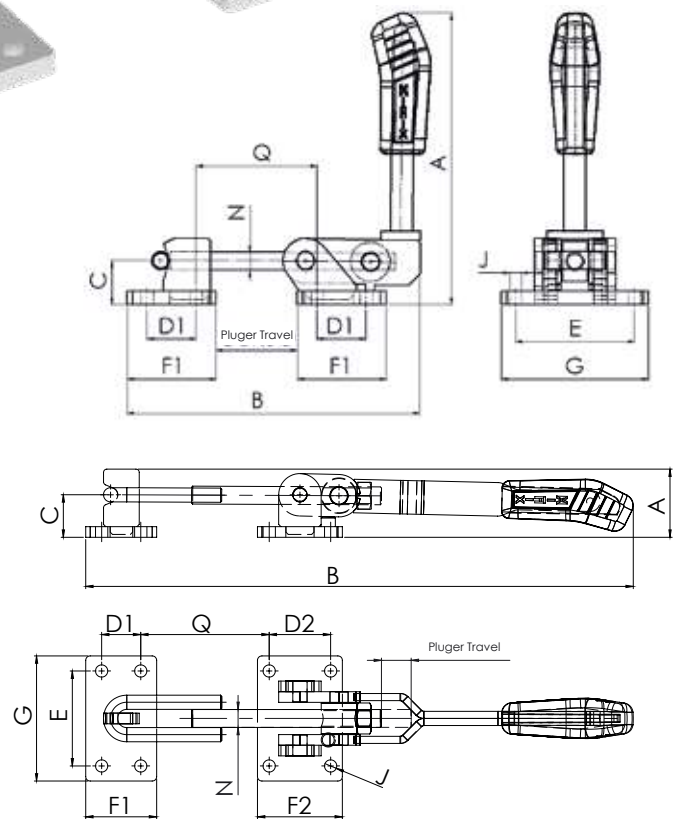

REFERENCE	RETENTION FORCE KGf (Lbf)	PLUNGER TRAVEL (IN)	A (IN)	B MÁX (IN)	C (IN)	D1 (IN)	D2 (IN)	E (IN)	F1 (IN)	F2 (IN)	G (IN)	J (IN)	N (IN)	Q (IN)	HOOK GOUGE	WEIGHT KG (LB)
Referencia	Fuerza Retención Kg (lbf)	Curso													Espesor Gancho	Peso
KF-330	1500 (3300)	48 (1,89)	208 (8,19)	209 (8,23)	31 (1,22)	35 (1,38)	-	85 (3,35)	63,5 (2,50)	-	105 (4,13)	8,5 (0,33)	12,7 (0,50)	86 (3,39)	M16	2,960 (6,512)
KF-350	1800 (3960)	50 (1,97)	246 (9,69)	239 (9,41)	44 (1,73)	35 (1,38)	-	94 (3,70)	60 (2,36)	-	120 (4,72)	11,0 (0,43)	16 (0,63)	80 (3,15)	M16	3,970 (8,734)
KF-340	2500 (5500)	53 (2,09)	61 (2,40)	490 (19,29)	38,1 (1,50)	35 (1,38)	55 (2,17)	85 (3,35)	63,5 (2,50)	76 (2,99)	112 (4,41)	11,0 (0,43)	16 (0,63)	115 (4,53)	M16	3,200 (7,040)

# PULL ACTION LATCH CLAMP PRENSA RÁPIDA DE GANCHO



KF-385

KF-375 TR

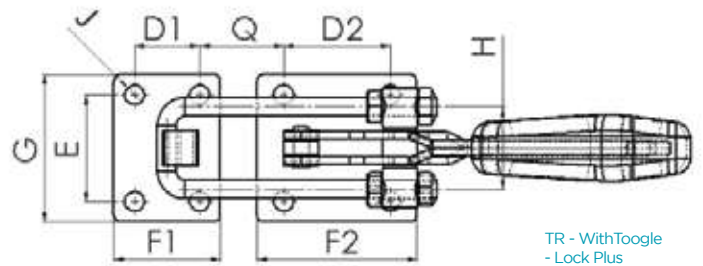
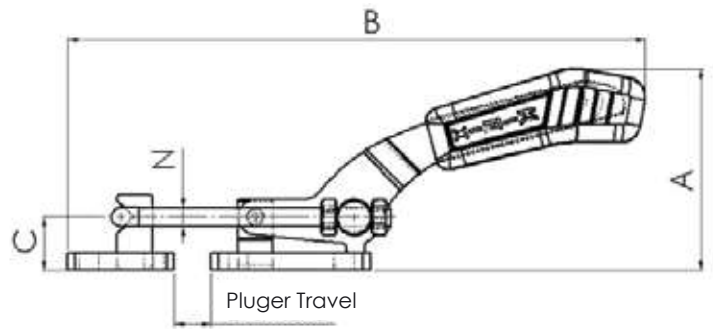

TR - With Toggle  
- Lock Plus  
TR - Bloqueo

REFERENCE	RETENTION FORCE KGf (LBF)	PLUNGER TRAVEL (IN)	A (IN)	B MÁX (IN)	C (IN)	D1 (IN)	D2 (IN)	E (IN)	F1 (IN)	F2 (IN)	G (IN)	H (IN)	J (IN)	N (IN)	Q (IN)	HOOK GAUGE	WEIGHT KG (LB)
Referencia	Fuerza Retención Kgf (lbf)	Curso														Espesor Gancho	Peso
KF-375	1500 (3300)	105 (4.13)	109 (4.29)	310 (12.20)	29 (1.14)	35 (1.38)	57.2 (2.25)	57.2 (2.25)	57 (2.24)	86 (3.39)	80 (3.15)	45 (1.77)	10.5 (0.41)	10 (0.39)	45 (1.77)	M10	1800 (3.960)
KF-375 TR	1500 (3300)	105 (4.13)	117 (4.61)	326 (12.83)	29 (1.14)	35 (1.38)	57.2 (2.25)	57.2 (2.25)	57 (2.24)	86 (3.39)	80 (3.15)	45 (1.77)	10.5 (0.41)	10 (0.39)	45 (1.77)	M10	2140 (4.708)
KF-385	3400 (7480)	105 (4.13)	106 (4.17)	310 (12.20)	29 (1.14)	35 (1.38)	57.2 (2.25)	57.2 (2.25)	57 (2.24)	86 (3.39)	80 (3.15)	54 (2.13)	10.5 (0.41)	12 (0.47)	50 (1.97)	M12	2200 (4.840)
KF - 385 TR	3400 (7480)	105 (4.13)	110 (4.33)	335 (13.18)	29 (1.14)	35 (1.38)	57.2 (2.25)	57.5 (2.26)	57 (2.24)	86 (3.39)	80 (3.15)	54 (2.13)	10.5 (0.41)	10.5 (0.41)	50 (1.97)	M12	2500 (5.511)



KFC3

**PADLOCK WILL NOT COME WITH THE CLAMP**  
**PADLOCK WILL NOT COME WITH THE CLAMP**

KFC5

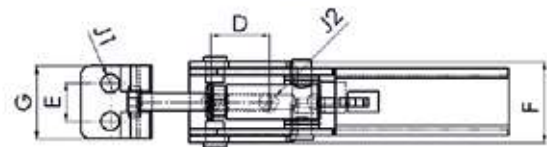
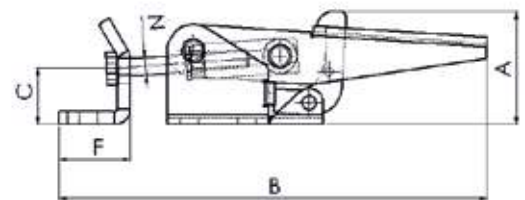
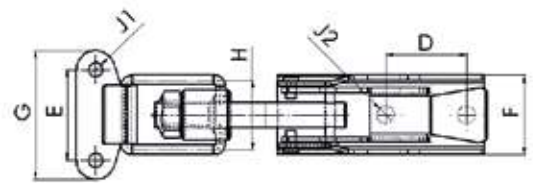
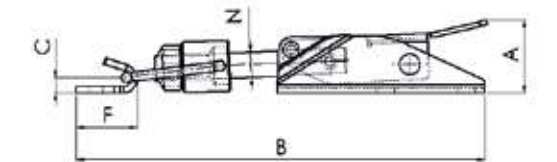

REFERENCE	RETENTION FORCE KGf (LBF)	PLUNGER TRAVEL (IN)	A (IN)	B (IN)	C (IN)	D (IN)	E (IN)	F (IN)	G (IN)	H (IN)	J1 (IN)	J2 (IN)	N (IN)	WEIGHT KG (LB)
Referencia	Fuerza Retención Kgf (lbf)	Curso												Peso
KFC3	3 (7)	24 (0.94)	23 (0.91)	128 (5.04)	5 (0.20)	25.5 (1.00)	28.5 (1.12)	19 (0.75)	40.5 (1.59)	22 (0.87)	4.4 (0.17)	5.5 (0.22)	8 (0.31)	0.130 (0.286)
KFC4	100 (220)	27 (1.06)	18.4 (0.72)	67 (6.57)	13 (0.51)	8 (0.31)	14.3 (0.56)	26 (1.02)	25.5 (1.00)	0	4.2 (1.66)	4.2 (1.66)	4 (0.15)	0.53 (1.16)
KFC5	180 (396)	60 (2.36)	38.9 (1.53)	148 (5.83)	17.5 (0.69)	20 (0.79)	13 (0.51)	24.5 (0.96)	25 (0.98)	-	6.4 (0.25)	6.4 (0.25)	6 (0.24)	0.235 (0.517)

# PULL ACTION LATCH CLAMP WITH STRAP

PRENSA RÁPIDA DE GANCHO CON CORREA



KF-233 CT 50



KF-743 CT 200



KF-843 CT 300

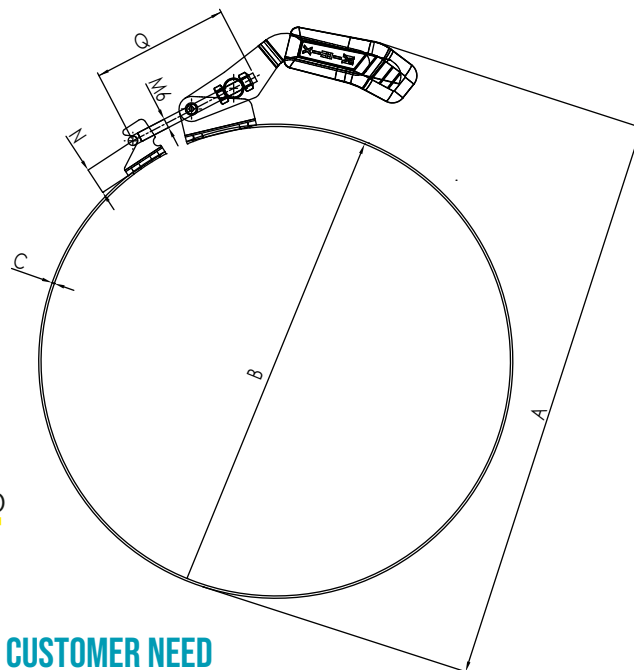
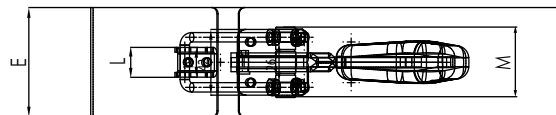

**STRAP PRODUCED ACCORDING TO A CUSTOMER NEED**

CORREA FABRICADA SEGÚN UNA NECESIDAD DEL CLIENTE

AVAILABLE IN PULL ACTION LATCH CLAMP: KF-233 | KF-743 | KF-843 - **PAG 26**

AVAILABLE IN PULL ACTION LATCH CLAMP: KF-233 | KF-743 | KF-843 - **PÁG 26**

CT - Strap  
CT - Correa

## EXAMPLE:

REFERENCE Referencia	RETENTION FORCE KGf (Lbf) Fuerza Retención Kgf (lbf)	PLUNGER TRAVEL (IN) Curso	A (IN)	B (IN)	C (IN)	E (IN)	L (IN)	M (IN)	N (IN)	Q (IN)	HOOK GOUGE Espesor Gancho	WEIGHT KG (LB) Peso
KF-233 CT50	160 (352)	14 (0,55)	100 (3,93)	50 (1,96)	1,5 (0,05)	25 (0,98)	4,3 (0,16)	19 (0,74)	4 (0,15)	53 (2,08)	M4	0,153 (0,337)
KF-743 CT200	200 (440)	16 (0,62)	236 (9,29)	200 (7,87)	1,5 (0,05)	30 (1,18)	6,3 (0,24)	25 (0,98)	5 (0,19)	65 (2,55)	M5	0,390 (0,859)
KF-843 CT300	200 (440)	16 (0,62)	365 (14,37)	250 (9,84)	1,5 (0,05)	70 (2,75)	19 (0,74)	70 (2,75)	6 (0,23)	90 (3,54)	M6	1,145 (2,524)

# STRAIGHT LINE ACTION CLAMP PRENSA RÁPIDA CON PISTÓN

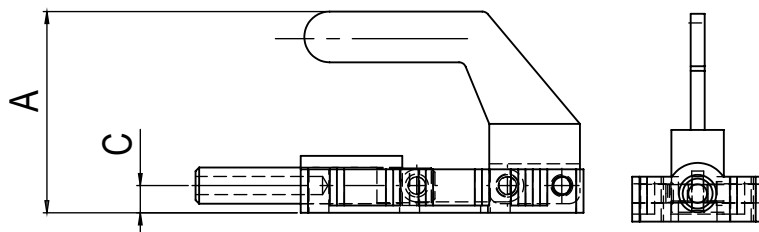
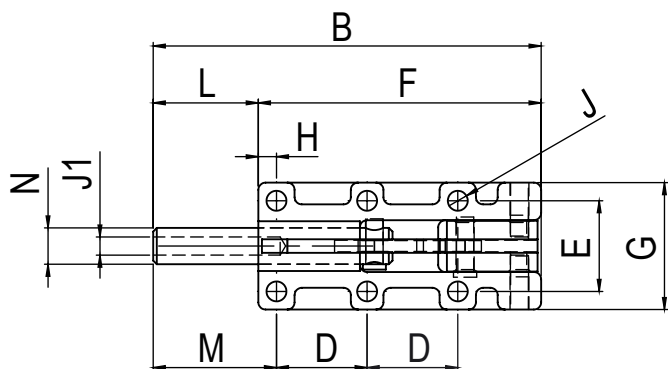
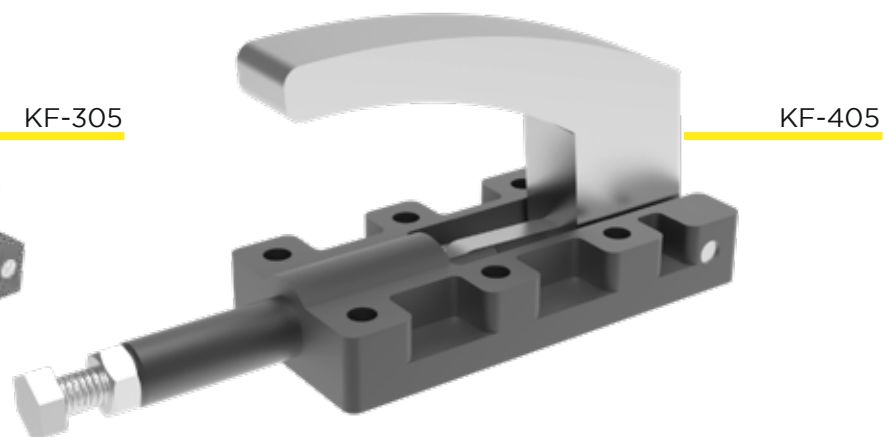
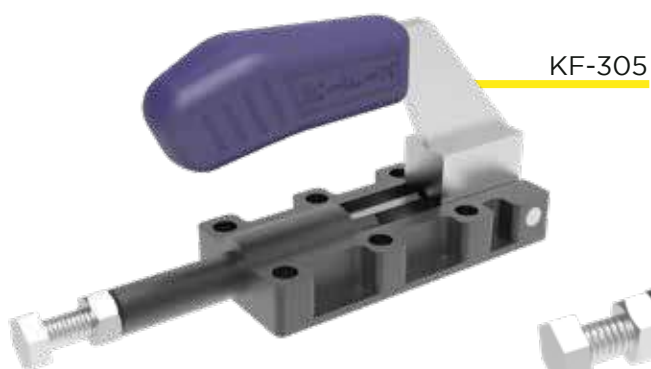
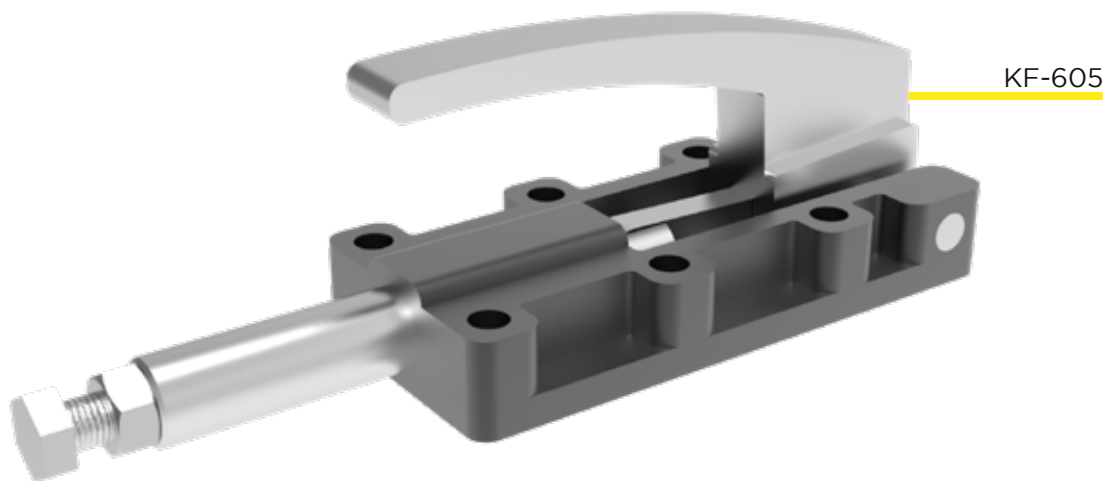

REFERENCE	RETENTION FORCE KGf (LBF)	PLUNGER TRAVEL (IN)	A (IN)	B (IN)	C (IN)	D (IN)	E (IN)	F (IN)	G (IN)	H (IN)	J (IN)	J1 (IN)	L (IN)	M (IN)	N (IN)	SPINDLE WEIGHT KG (LB)	
Referencia	Fuerza Retención Kgf (lbf)	Curso														Tornillo Peso	
KF-305	250 (550)	25 (0.98)	60 (2.36)	105 (4.13)	7.5 (0.30)	25 (0.98)	25 (0.98)	78 (3.07)	35 (1.38)	5 (0.20)	5.5 (0.22)	M6x1.00	26.5 (1.04)	32 (1.26)	10 (0.39)	M6	0.350 (0.770)
KF-405	500 (1100)	35 (1.38)	73 (2.87)	148 (5.83)	10 (0.39)	35 (1.38)	35 (1.38)	111 (4.37)	51 (2.01)	8.5 (0.33)	6.5 (0.26)	M8x1.25	37 (1.46)	46 (1.81)	14 (0.55)	M8	1.100 (2.420)
KF-505	750 (1650)	50 (1.97)	78 (3.07)	190 (7.48)	14 (0.55)	45 (1.77)	45 (1.77)	141 (5.55)	66 (2.60)	10 (0.39)	8.5 (0.33)	M12x1.75	50 (1.97)	60 (2.36)	19 (0.75)	M12	1.820 (4.004)
KF-605	1200 (2640)	60 (2.36)	84 (3.31)	238 (9.37)	16 (0.63)	55 (2.17)	55 (2.17)	171 (6.73)	76 (2.99)	10 (0.39)	10.5 (0.41)	M12x1.75	67 (2.64)	77 (3.03)	22 (0.87)	M12	2.870 (6.314)
KF-067	1500 (3306)	41.5 (1.63)	97 (3.81)	151.5 (0.59)	17.5 (0.68)	35 (1.37)	41 (1.61)	107.5 (4.23)	55 (2.16)	16 (0.62)	7 (0.27)	M8x1.25	43 (1.69)	61 (2.40)	12 (0.47)	M8	0.676 (1.490)



# STRAIGHT LINE ACTION CLAMP PRENSA RÁPIDA CON PISTÓN



KF-057 TR



KF-061



KF-051



KF-053

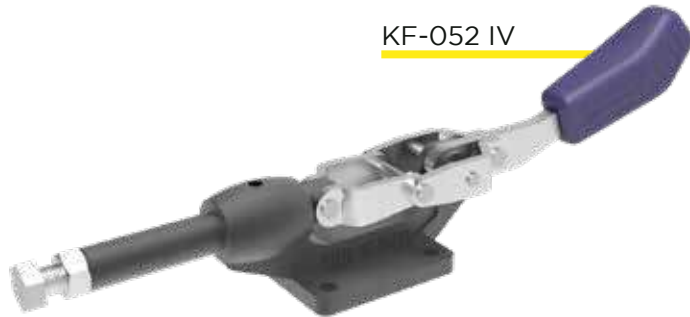

KF-052 IV

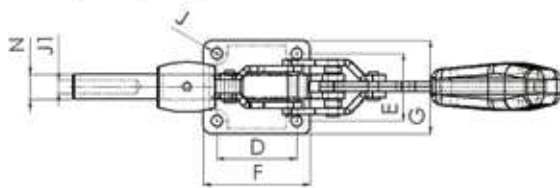
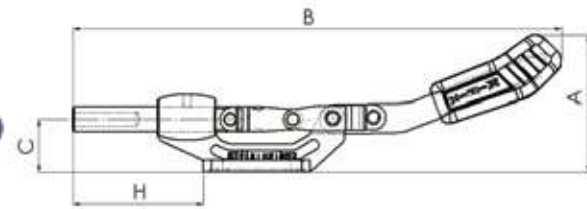
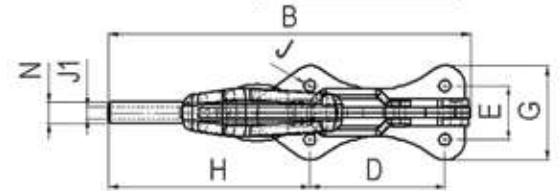
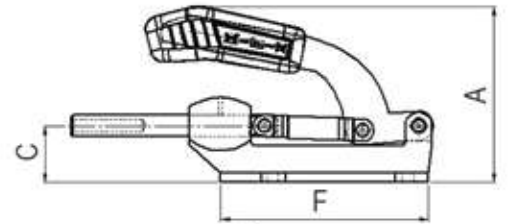
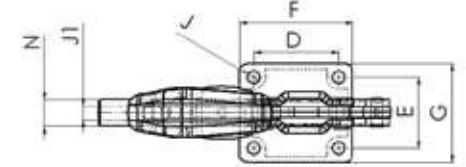
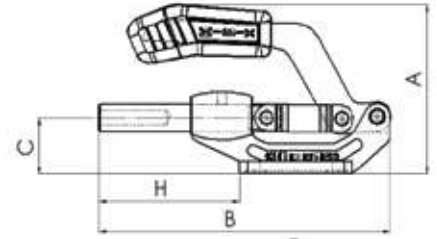

TR - With Toogle-Lock Plus  
IV - Reversed Handle  
RF - Enhanced Base

TR - Bloqueo  
IV - Acción Inversa  
RF - Base Mejorada

REFERENCE	RETENTION FORCE KGf (LBF)	PLUNGER TRAVEL (IN)	A (IN)	B (IN)	C (IN)	D (IN)	E (IN)	F (IN)	G (IN)	H (IN)	J (IN)	J1 (IN)	N (IN)	SPINDLE	WEIGHT KG (LB)
Referencia	Fuerza Retención Kg (lbf)	Curso												Tornillo	Peso
KF-061	50 (110)	16 (0.63)	51.3 (2.02)	66.1 (2.60)	13.7 (0.54)	16 (0.63)	16 (0.63)	35.4 (1.39)	26.7 (1.05)	22.5 (0.89)	4.3 (0.17)	M4X0.70	6.35 (0.25)	M4	0.070 (0.154)
KF-057	230 (506)	36 (1.42)	82 (3.23)	144 (5.67)	25 (0.98)	35 (1.38)	40 (1.57)	50 (1.97)	55 (2.17)	71 (2.80)	7.0 (0.28)	M8X1.25	12 (0.47)	M8	0.400 (0.880)
KF-057 TR	230 (506)	36 (1.42)	98 (3.86)	144 (5.67)	25 (0.98)	35 (1.38)	40 (1.57)	50 (1.97)	55 (2.17)	71 (2.80)	7.0 (0.28)	M8X1.25	12 (0.47)	M8	0.420 (0.924)
KF-057 IV	230 (506)	35 (1.38)	34 (1.34)	239 (9.41)	25 (0.98)	35 (1.38)	40 (1.57)	50 (1.97)	55 (2.17)	71 (2.80)	7.0 (0.28)	M8X1.25	12 (0.47)	M8	0.395 (0.869)
KF-051	270 (594)	35 (1.38)	92.2 (3.63)	125 (4.92)	24.8 (0.98)	36.6 (1.44)	33.3 (1.31)	58 (2.28)	48 (1.89)	57 (2.24)	6.3 (0.25)	M8X1.25	12 (0.47)	M8	0.390 (0.858)
KF-054	380 (836)	37 (1.45)	107.9 (4.25)	154 (6.06)	31.8 (1.25)	41.4 (1.63)	41.4 (1.63)	58.7 (2.31)	57.2 (2.25)	42.2 (1.66)	8.5 (0.33)	M10X1.50	16 (0.63)	M10	0.890 (1.958)
KF-054 IV	380 (836)	46 (1.81)	57.2 (22.51)	339 (13.34)	31.8 (1.25)	41.4 (1.63)	41.4 (1.63)	158 (6.22)	57.2 (2.25)	81 (3.18)	8.5 (0.33)	M10X1.50	16 (0.63)	M10	0.93 (2.050)
KF-053	500 (1100)	83 (3.27)	127 (5.00)	268 (10.55)	42 (1.65)	100 (3.94)	40 (1.57)	154 (6.06)	70 (2.76)	149 (5.87)	8.5 (0.33)	M10X1.50	16 (0.63)	M10	2.150 (4.730)
KF-053 TR	500 (1100)	83 (3.27)	134 (5.28)	268 (10.55)	42 (1.65)	100 (3.94)	40 (1.57)	154 (6.06)	70 (2.76)	149 (5.87)	8.5 (0.33)	M10X1.50	16 (0.63)	M12	2.220 (4.884)
KF-052	700 (1540)	50 (1.97)	116 (4.57)	205 (8.07)	40 (1.57)	60 (2.36)	50 (1.97)	80 (3.15)	70 (2.76)	99 (3.90)	8.5 (0.33)	M12X1.75	19 (0.75)	M12	1.280 (2.816)
KF-052 TR	700 (1540)	50 (1.97)	137 (5.39)	205 (8.07)	40 (1.57)	60 (2.36)	50 (1.97)	80 (3.15)	70 (2.76)	99 (3.90)	8.5 (0.33)	M12X1.75	19 (0.75)	M12	1.710 (3.762)
KF-052 IV	700 (1540)	49 (1.92)	103 (4.06)	368 (14.49)	40 (1.57)	60 (2.36)	50 (1.97)	80 (3.15)	70 (2.76)	98 (3.86)	8.5 (0.33)	M12X1.75	19 (0.75)	M12	1.590 (3.498)
KF-052 RF	1200 (2640)	50 (1.97)	120 (4.72)	205 (8.07)	40 (1.57)	60 (2.36)	50 (1.97)	80 (3.15)	70 (2.76)	99 (3.90)	8.5 (0.33)	M12X1.75	19 (0.75)	M16	1.660 (3.652)
KF-056	1800 (3960)	78 (3.07)	150 (5.91)	287 (11.30)	57 (2.24)	100 (3.94)	60 (2.36)	162 (6.38)	86 (3.39)	162 (6.38)	10.5 (0.41)	M16X2.00	25 (0.98)	M16	3.500 (7.700)

# STRAIGHT LINE ACTION CLAMP WITH HANDLE

PRENSA CON PISTÓN CON MANGO



KF-025 AL

KF-054 AL

KF-052 AL

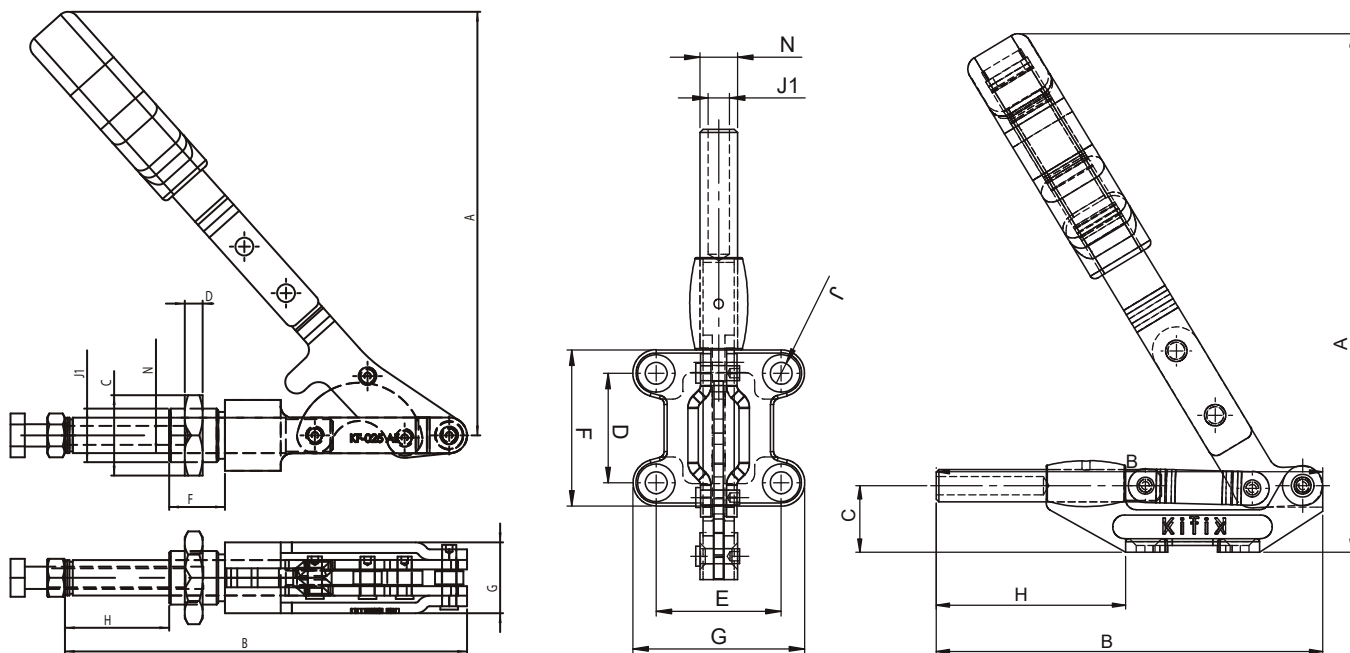

AL - Alça

REFERENCE	RETENTION FORCE KGf (Lbf)	PLUNGER TRAVEL (IN)	A (IN)	B (IN)	C (IN)	D (IN)	E (IN)	F (IN)	G (IN)	H (IN)	J (IN)	J1 (IN)	N (IN)	SPINDLE	WEIGHT KG (LB)
Referencia	Fuerza Retención Kgf (lbf)	Curso												Tornillo	Peso
KF-025 AL	500 (1102)	46 (1,81)	190 (7,48)	180 (7,08)	36 (1,41)			26 (1,02)	31,75 (1,24)	47 (1,85)		M24X2,00	16	M10	1,307 (2,88)
KF-057 AL	230 (506)	36 (1,42)	193 (7,59)	144 (5,67)	25 (0,98)	35 (1,38)	40 (1,57)	50 (1,97)	55 (2,17)	71 (2,80)	7,0 (0,28)	M8X1,25	12 (0,47)	M8	0,820 (1,807)
KF-056 AL	250 (551)	79 (3,11)	206 (47,48)	287 (11,29)	57 (2,24)	100 (3,93)	60 (2,36)	154 (6,06)	86 (3,38)	162 (6,37)	10,5 (0,41)	M16X2,0	25 (0,98)	M16	3,52 (7,76)
KF-054 AL	380 (836)	41 (1,61)	196 (7,71)	154 (6,06)	40 (1,57)	41,4 (1,63)	41,4 (1,63)	58,7 (2,31)	57,2 (2,25)	42,2 (1,66)	8,5 (0,33)	M10X1,50	16 (0,63)	M10	1,205 (2,656)
KF-053 AL	500 (1102)	87 (3,42)	180 (7,08)	264 (10,39)	42 (1,65)	100 (3,93)	40 (1,57)	154 (6,06)	70 (2,75)	149 (5,86)	8,5 (0,33)	M10X1,50	16 (0,63)	M10	2,16 (4,76)
KF-052 AL	700 (1540)	50 (1,97)	215 (8,46)	205 (8,07)	40 (1,57)	60 (2,36)	50 (1,97)	80 (3,15)	70 (2,76)	99 (3,90)	8,5 (0,33)	M12X1,75	19 (0,75)	M12	1,550 (3,417)

# STRAIGHT LINE ACTION CLAMP WITH TURNING

PRENSA CON PISTÓN CON GIRATORIO

WITH SWIVEL OPTION FOR  
RIGHT AND LEFT

CON OPCIÓN DE ROTAR  
DERECHA E IZQUIERDA

KF-007 G

Upper view  
Vista superior



Side view  
Vista lateral

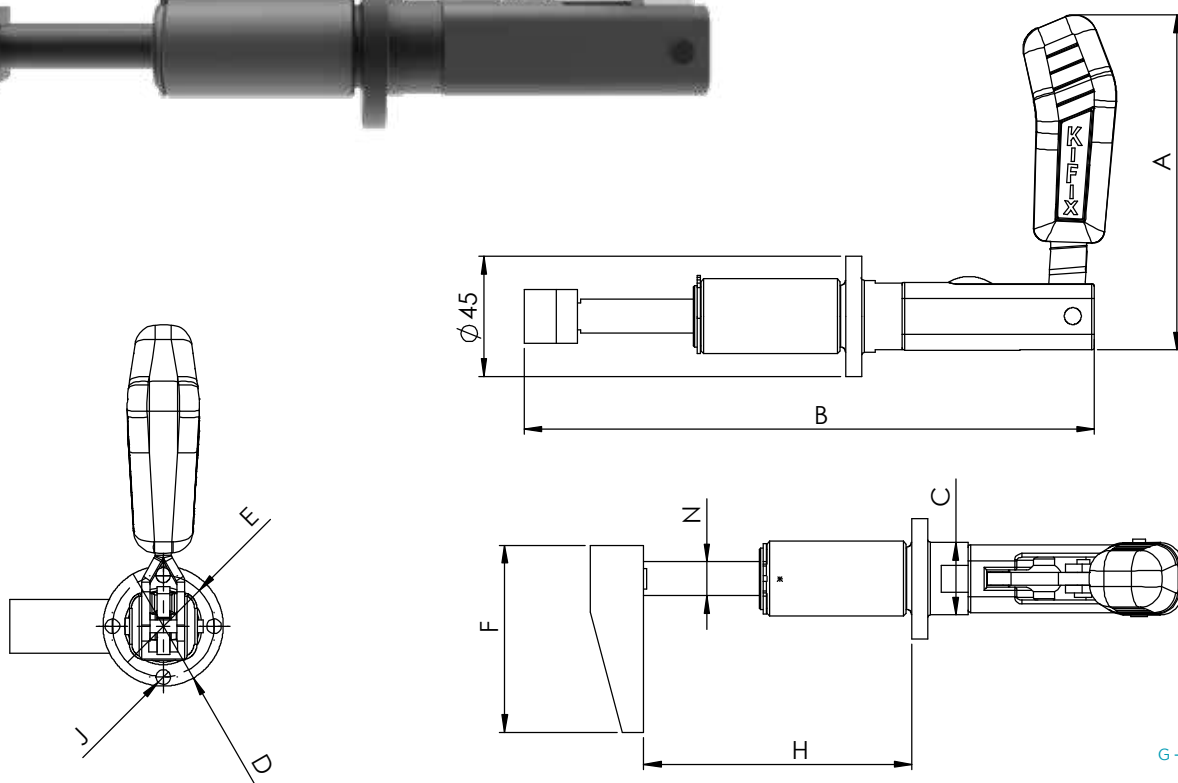

G - Giro

REFERENCE	RETENTION FORCE KGf (Lbf)	PLUNGER TRAVEL (IN)	A (IN)	B (IN)	C (IN)	D (IN)	E (IN)	F (IN)	H (IN)	J (IN)	N (IN)	WEIGHT KG (LB)
Referencia	Fuerza Retención Kgf (lbf)	Curso										Peso
KF-007 G	200 (440)	42 (1,65)	125 (4,92)	213 (8,38)	27 (1,06)	45 (1,77)	38 (1,49)	70 (2,75)	100 (3,93)	5,5 (0,21)	12,7 (0,5)	0,925 (2,039)

# STRAIGHT LINE ACTION CLAMP PRENSA CON PISTÓN FIJACIÓN FRONTAL



KF-005



KF-006



KF-007 TR

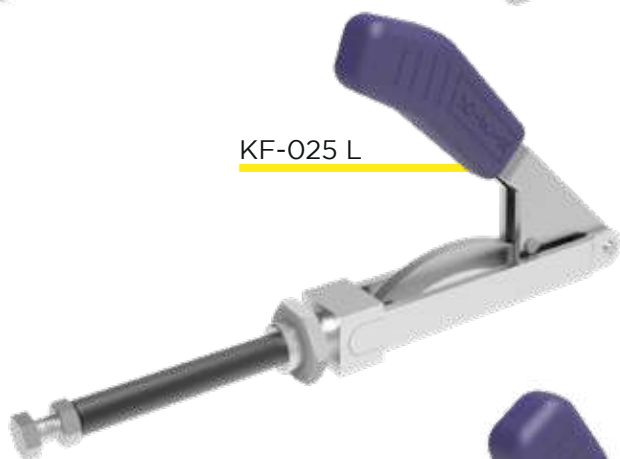

KF-025 L



KF-015 TR



KF-035

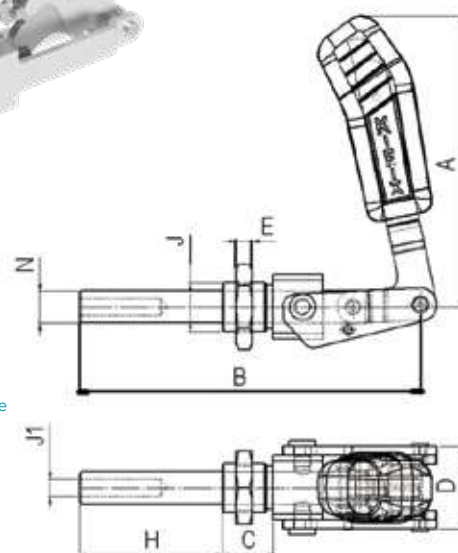

**BAR**  
L - Long U - Bar  
IV - Inverted

TR - With Toogle  
-Lock Plus  
A - Open

**BRAZO**  
L - Largo  
IV - Invetido

TR - Bloqueo  
A - Abierto

REFERENCE	RETENTION FORCE KGF (LBF)	PLUNGER TRAVEL (IN)	A (IN)	B (IN)	C (IN)	D (IN)	E (IN)	H (IN)	J (IN)	J1 (IN)	N (IN)	SPINDLE	WEIGHT KG (LB)
Referencia	Fuerza Retención Kgf (lbf)	Curso										Tornillo	Peso
KF-005	90 (198)	20 (0.79)	79 (3.11)	60 (2.36)	12 (0.47)	26 (1.02)	7.8 (0.31)	21 (0.83)	M16X1.50	M6X1.00	9.5 (0.37)	M6	0.190 (0.418)
KF-006	120 (264)	39 (1.54)	107 (4.21)	105 (4.13)	16.5 (0.65)	31 (1.22)	8.5 (0.33)	39 (1.54)	M20X1.50	M8X1.25	12 (0.47)	M8	0.420 (0.924)
KF-009	150 (330)	60 (2.36)	109 (4.29)	138 (5.43)	16.5 (0.65)	31 (1.22)	7 (0.27)	62 (2.44)	M20X1.50	M8X1.25	12 (0.47)	M8	0.460 (1.01)
KF-007	200 (440)	41 (1.61)	125 (4.92)	125 (4.92)	18 (0.71)	25.4 (1.00)	8.5 (0.33)	42 (1.65)	M20X1.50	M8X1.25	12.7 (0.50)	M8	0.490 (1.078)
KF-007 TR	200 (440)	41 (1.61)	135 (5.31)	125 (4.92)	18 (0.71)	25.4 (1.00)	8.5 (0.33)	42 (1.65)	M20X1.50	M8X1.25	12.7 (0.50)	M8	0.515 (1.133)
KF-007 TR A	200 (440)	41 (1.61)	135 (5.31)	125 (4.92)	18 (0.71)	25.4 (1.00)	7 (0.27)	43 (1.69)	M20X1.50	M8X1.25	12.7 (0.50)	M8	0.508 (1.12)
KF-015	250 (550)	34 (1.34)	115 (4.53)	137 (5.39)	20 (0.79)	25 (0.98)	8.5 (0.33)	35 (1.38)	M20X1.50	M8X1.25	12 (0.47)	M8	0.470 (1.034)
KF-015 TR	250 (550)	34 (1.34)	142 (5.59)	137 (5.39)	20 (0.79)	25 (0.98)	8.5 (0.33)	35 (1.38)	M20X1.50	M8X1.25	12 (0.47)	M8	0.540 (1.188)
KF-015 IV	250 (550)	34 (1.34)	125 (4.92)	142 (5.59)	20 (0.79)	25 (0.98)	8.5 (0.33)	35 (1.38)	M20X1.50	M8X1.25	12 (0.47)	M8	0.470 (1.034)
KF-015 F 90	250 (550)	35 (1.37)	180 (7.08)	142 (5.59)	20 (0.79)	25 (0.98)	7 (0.27)	35 (1.38)	M20X1.50	M8X1.25	12 (0.47)	M8	0.570 (1.256)
KF-025	500 (1100)	40 (1.57)	132 (5.20)	180 (7.09)	25 (0.98)	32 (1.26)	10 (0.39)	47 (1.85)	M24X2.00	M10X1.50	16 (0.63)	M10	0.990 (2.178)
KF-025 TR	500 (1100)	40 (1.57)	132 (5.20)	180 (7.09)	25 (0.98)	32 (1.26)	10 (0.39)	47 (1.85)	M24X2.00	M10X1.50	16 (0.63)	M10	1.020 (2.244)
KF-025 L	300 (660)	99 (3.90)	151 (5.94)	316 (12.44)	25 (0.98)	32 (1.26)	10 (0.39)	102 (4.02)	M24X2.00	M10X1.50	16 (0.63)	M10	1.400 (3.080)
KF-035	320 (704)	66 (2.60)	143 (5.63)	175 (6.89)	25 (0.98)	40 (1.57)	10 (0.39)	70 (2.76)	M24X2.00	M10X1.50	16 (0.63)	M10	0.920 (2.024)
KF-035 TR	320 (704)	66 (2.60)	143 (5.63)	175 (6.89)	25 (0.98)	40 (1.57)	10 (0.39)	70 (2.76)	M24X2.00	M10X1.50	16 (0.63)	M10	0.980 (2.156)

# STRAIGHT LINE ACTION CLAMP PRENSA CON PISTÓN FIJACIÓN FRONTAL

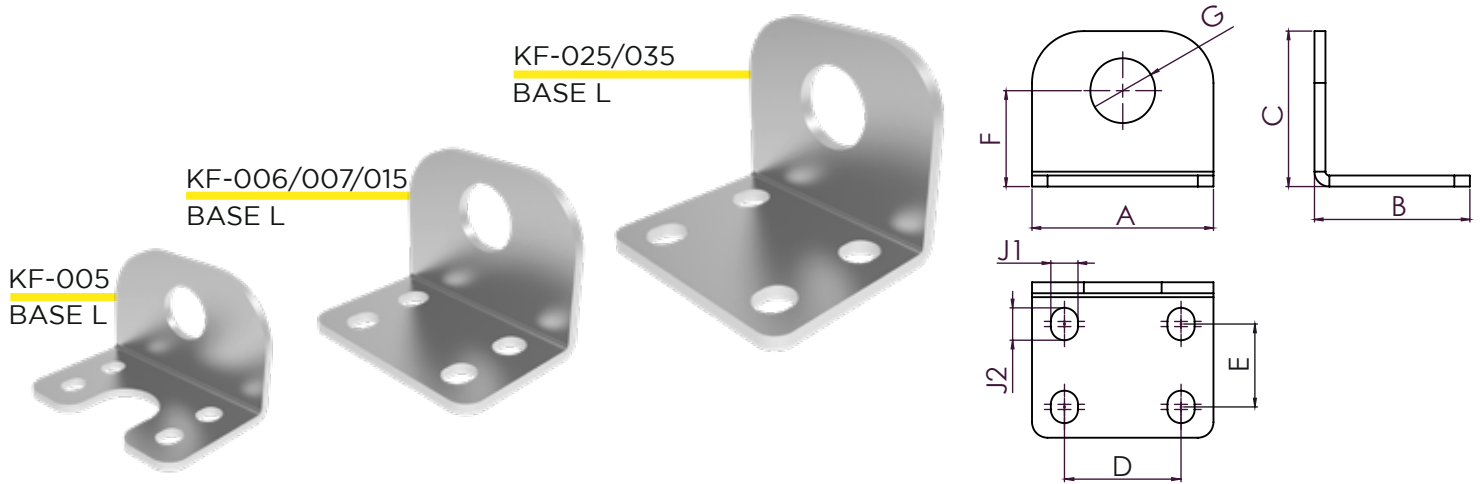

REFERENCE Referencia	A (IN)	B (IN)	C (IN)	D (IN)	E (IN)	F (IN)	G (IN)	J1 (IN)	J2 (IN)	WEIGHT KG (LB) Peso
KF-005 BASE L	60 (2,36)	40 (1,57)	40 (1,57)	40 (1,57)	16 (0,63)	24 (0,94)	16,5 (0,65)	8,5 (0,33)	8,5 (0,33)	0,075 (0,165)
KF-006/007/015 BASE L	65 (2,56)	44 (1,73)	50 (1,97)	40 (1,57)	20 (0,79)	33 (1,30)	20,5 (0,81)	8,5 (0,33)	10,5 (0,41)	0,140 (0,308)
KF-025/035 BASE L	70 (2,76)	60 (2,36)	60 (2,36)	45 (1,77)	32 (1,26)	37 (1,46)	25 (0,98)	10,5 (0,41)	12,5 (0,49)	0,250 (0,550)

# STRAIGHT LINE ACTION CLAMP SQUARE PLUNGER PRENSA CON PISTÓN CUADRADO



KFKT-012



KFKT-012 F

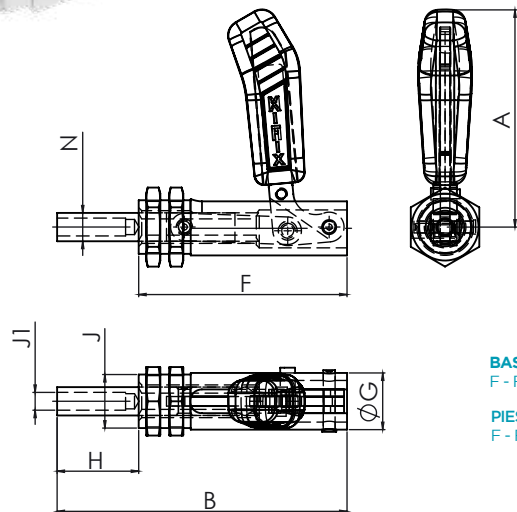
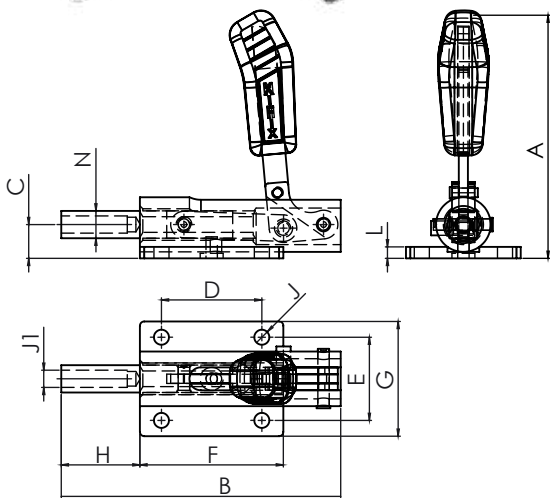

**BASES**  
F - Front Base  
**PIES**  
F - Frontal

REFERENCE Referencia	RETENTION FORCE KGf (Lbf) Fuerza Retención Kgf (lbf)	PLUNGER TRAVEL (IN) Curso	A (IN)	B (IN)	C (IN)	D (IN)	E (IN)	F (IN)	G (IN)	H (IN)	J (IN)	J1 (IN)	L (IN)	N (IN)	SPINDLE Tornillo	WEIGHT KG (LB) Peso
KFKT-012	900 (1980)	48 (1,89)	173 (6,81)	195 (7,68)	23,6 (0,93)	70 (2,76)	58 (2,28)	100 (3,94)	80 (3,15)	55 (2,17)	10,5 (0,41)	M12X1,75	8 (0,31)	19 (0,75)	M12	1,850 (4,070)
KFKT-012 F	900 (1980)	48 (1,89)	146 (5,75)	195 (7,68)	-	-	-	140 (5,51)	38,1 (1,50)	55 (2,17)	M36X1,50	M12X1,75	-	19 (0,75)	M12	1,530 (3,366)



# DOUBLE CLAMPS PRENSA DOBLE

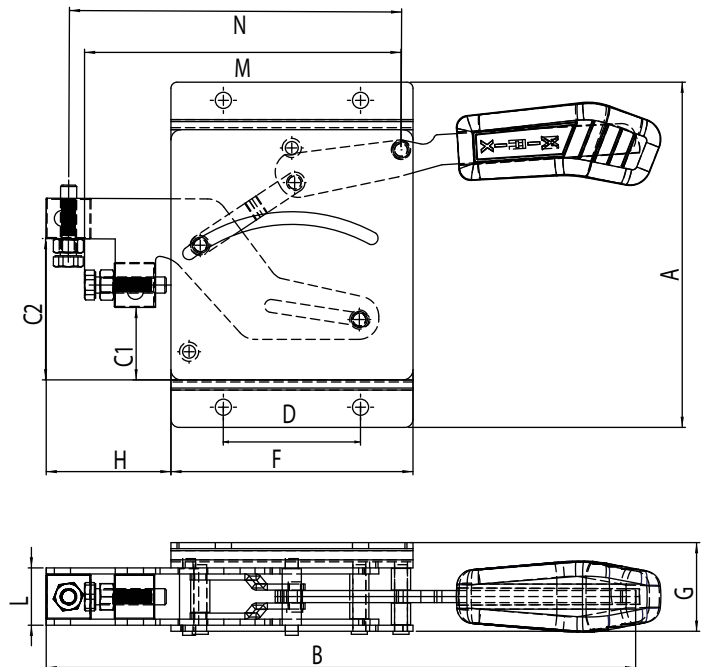
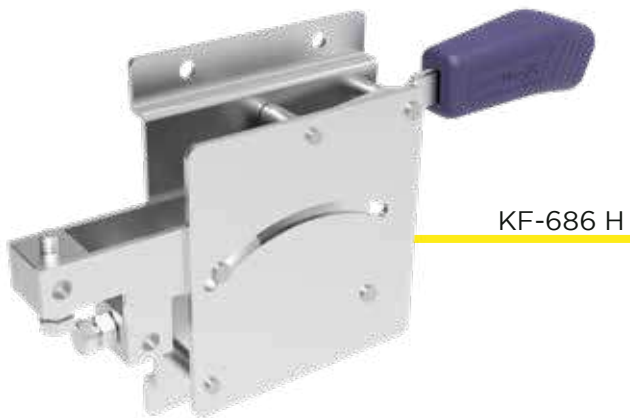
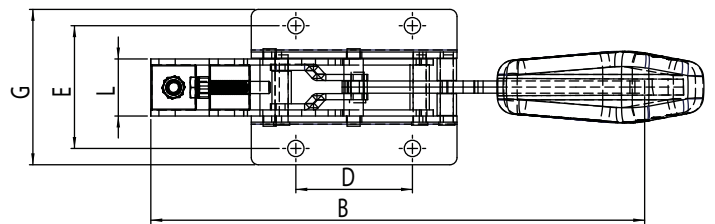
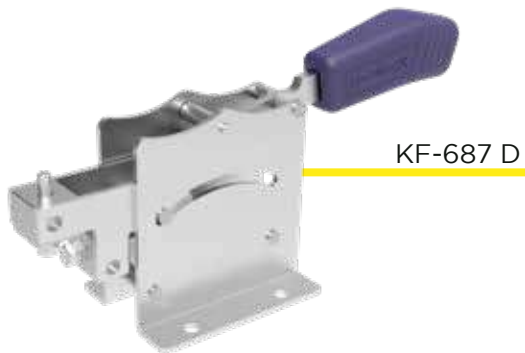
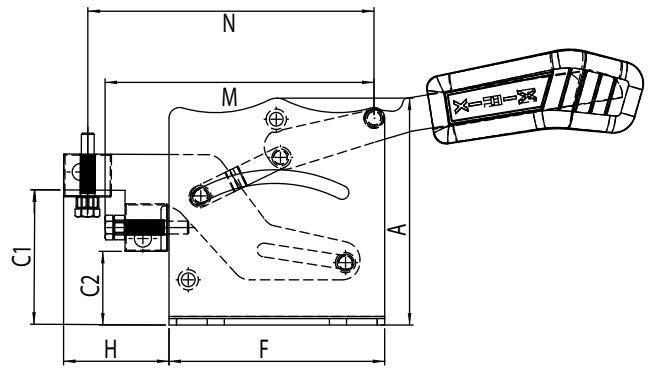
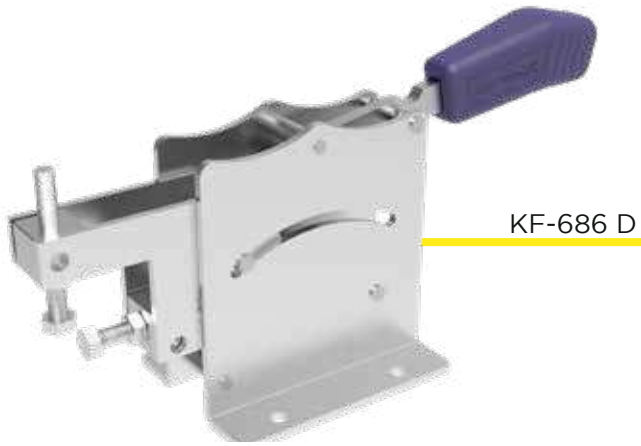

**BASES**

D - Flanged Base  
H - Horizontal

**PIES**

D - Doblado  
H - Horizontal

REFERENCE	RETENTION FORCE KGF (LBF)	A (IN)	B (IN)	C1 (IN)	C2 (IN)	D (IN)	E (IN)	F (IN)	G (IN)	H (IN)	L (IN)	M (IN)	N (IN)	SPINDLE	WEIGHT KG (LB)
Referencia	Fuerza Retención Kgf (lbf)													Tornillo	Peso
KF-686 D	533,72 (1176,65)	144 (5,66)	297 (11,69)	38 (1,49)	61 (2,40)	68 (2,67)	73 (2,87)	120 (4,72)	93 (3,66)	58 (2,28)	31 (1,22)	162 (6,37)	172 (6,77)	M8	2,18 (4,80)
KF-686 H	557,47 (1229,00)	171 (6,73)	292 (11,49)	36 (1,41)	70 (2,75)	68 (2,67)	-	120 (4,72)	44 (1,73)	62 (2,44)	28 (1,10)	157 (6,18)	165 (2,55)	M8	1,59 (3,50)
KF-687 D	685,30 (1510,82)	106 (4,17)	242 (9,52)	35 (1,37)	63 (2,48)	57 (2,24)	60 (2,36)	101 (3,97)	76 (2,99)	49 (1,92)	28 (1,10)	126 (4,96)	134 (5,27)	M8	1,18 (2,60)

# VARIABLE STROKE HUSILLO RÁPIDO

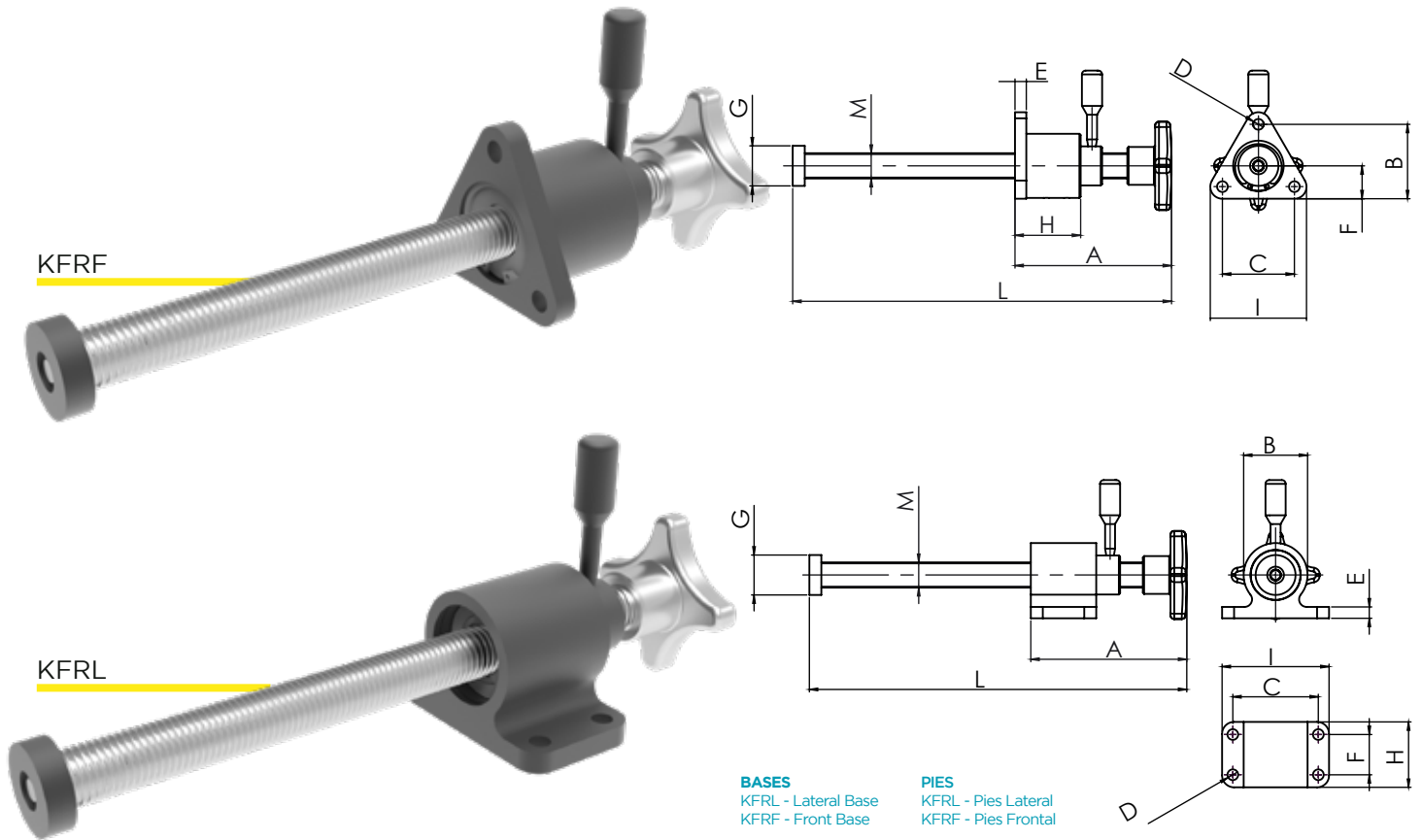

REFERENCE	RETENTION FORCE KGF (LBF)	A (IN)	B (IN)	C (IN)	D (IN)	E (IN)	F (IN)	G (IN)	H (IN)	I (IN)	L (IN)	M (IN)	WEIGHT KG (LB)
Referencia	Fuerza Retención Kgf (lbf)												Peso
KFRL-12	500 (1100)	64,5 (2,54)	35 (1,38)	45 (1,77)	5,5 (0,22)	6 (0,24)	20 (0,79)	19 (0,75)	32 (1,26)	55 (2,17)	175,4 (6,91)	M12X1,75	0,480 (1,056)
KFRF-12	500 (1100)	64,5 (2,54)	38,9 (1,53)	38 (1,50)	5,5 (0,22)	6 (0,24)	17 (0,67)	19 (0,75)	32 (1,26)	50 (1,97)	175,4 (6,91)	M12X1,75	0,420 (0,924)
KFRL-16	750 (1650)	93,7 (3,69)	40 (1,57)	53 (2,09)	7 (0,28)	8 (0,31)	28 (1,10)	25 (0,98)	40 (1,57)	65 (2,56)	249 (9,80)	M16X2,00	0,920 (2,024)
KFRF-16	750 (1650)	93,7 (3,69)	50 (1,97)	48,5 (1,91)	7 (0,28)	8 (0,31)	22 (0,87)	25 (0,98)	40 (1,57)	64,5 (2,54)	249 (9,80)	M16X2,00	0,820 (1,804)
KFRL-20	1500 (3300)	116 (4,57)	50,8 (2,00)	68 (2,68)	8,5 (0,33)	9 (0,35)	32 (1,26)	32 (1,26)	52 (2,05)	85 (3,35)	292 (11,50)	M20X2,00	1,950 (4,290)
KFRF-20	1500 (3300)	116 (4,57)	59 (2,32)	57 (2,24)	8,5 (0,33)	9 (0,35)	26,1 (1,03)	32 (1,26)	52 (2,05)	76 (2,99)	292 (11,50)	M20X2,00	1,750 (3,850)

# HANDLESS TIRADORES

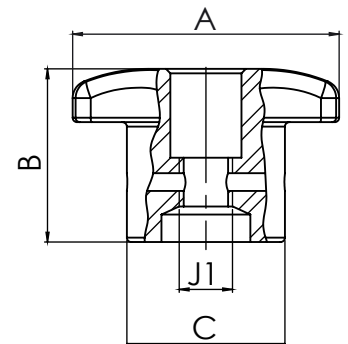

**VERSIONES DISPONIBLES:**  
Acero cincado en blanco  
Oxidado en negro

REFERENCE	A (IN)	B (IN)	C (IN)	J1 (IN)	WEIGHT KG (LB)
Referencia					Peso
KFM-6	30 (1,18)	16 (0,63)	16 (0,63)	M6X1,00	0,055 (0,121)
KFM-8	41 (1,61)	20 (0,79)	19,5 (0,77)	M8X1,25	0,105 (0,231)
KFM-10	48 (1,89)	24 (0,94)	22 (0,87)	M10X1,50	0,165 (0,363)
KFM-12	67 (2,64)	30 (1,18)	26 (1,02)	M12X1,75	0,305 (0,672)
KFM-16	80 (3,15)	45 (1,77)	40 (1,57)	M16x2,00	0,575 (1,267)

# CARVER CLAMP PRENSA SARGENTO

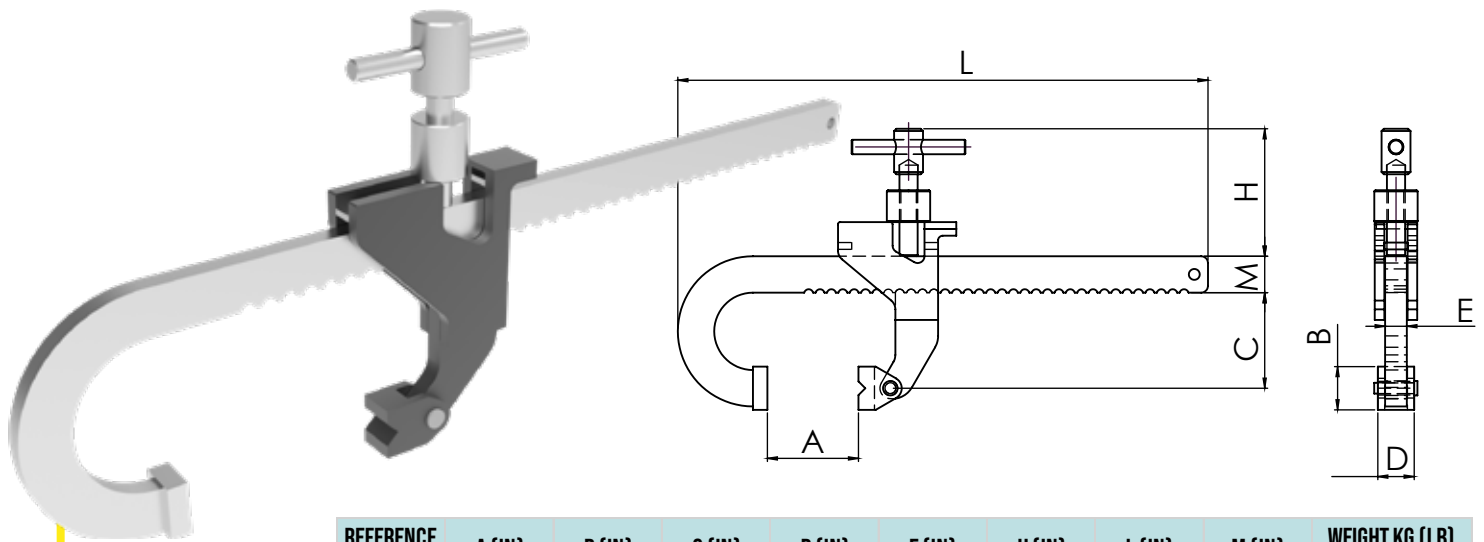

KF-150

REFERENCE	A (IN)	B (IN)	C (IN)	D (IN)	E (IN)	H (IN)	L (IN)	M (IN)	WEIGHT KG (LB)
Referencia									Peso
KFS-150	150 (5,91)	19 (0,75)	42 (1,65)	16 (0,63)	9,5 (0,37)	50 (1,97)	233 (9,17)	16 (0,63)	0,600 (1,320)
KFS-300	320 (12,60)	25,4 (1,00)	81 (3,19)	19 (0,75)	9,5 (0,37)	85 (3,35)	472 (18,58)	22 (0,87)	1,900 (4,180)

# COMPRESSOR CLAMP PRENSA DE COMPRESIÓN

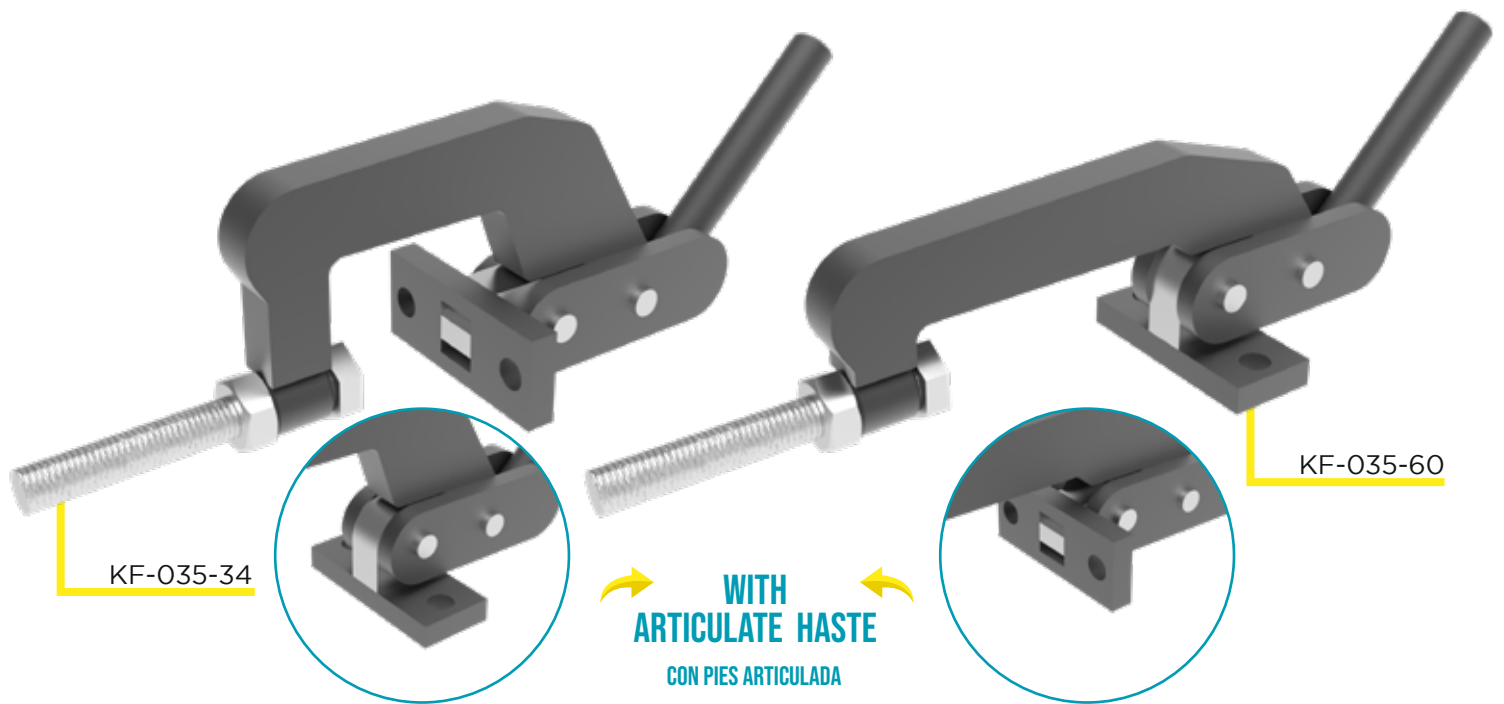

KF-035-34

KF-035-60

WITH  
ARTICULATE HASTE  
CON PIES ARTICULADA

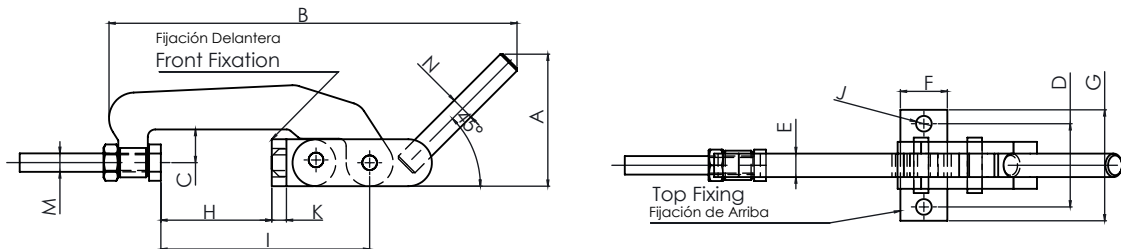

REFERENCE	RETENTION FORCE KGf (LBF)	A (IN)	B (IN)	C (IN)	D (IN)	E (IN)	F (IN)	G (IN)	H (IN)	I (IN)	J (IN)	K (IN)	M (IN)	N (IN)	SPINDLE	WEIGHT KG (LB)
Referencia	Fuerza Retención Kgf (lbf)														Tornillo	Peso
KF-035 34	1000 (2200)	71 (2,80)	195 (7,68)	36 (1,42)	45 (1,77)	12,7 (0,50)	25,4 (1,00)	60 (2,36)	34 (1,34)	87 (3,43)	8,5 (0,33)	7,94 (0,31)	M10	12,7 (0,50)	M10	0,910 (2,002)
KF-035 60	1000 (2200)	71 (2,80)	221 (8,70)	18 (0,71)	45 (1,77)	12,7 (0,50)	25,4 (1,00)	60 (2,36)	60 (2,36)	113 (4,45)	8,5 (0,33)	7,94 (0,31)	M10	12,7 (0,50)	M10	0,890 (1,958)
KF-035 3660	1000 (2200)	71 (2,80)	221 (8,70)	36 (1,42)	45 (1,77)	12,7 (0,50)	25,4 (1,00)	60 (2,36)	60 (2,36)	113 (4,45)	8,5 (0,33)	7,94 (0,31)	M10	12,7 (0,50)	M10	0,955 (2,101)
KF-035 100	2000 (4400)	101 (3,98)	318 (12,52)	70 (2,76)	68 (2,68)	15,9 (0,63)	40 (1,57)	88 (3,46)	100 (3,94)	164 (6,46)	10,5 (0,41)	12,7 (0,50)	M10	15,9 (0,63)	M10	2,215 (4,873)

# PNEUMATIC CLAMP PRENSA NEUMÁTICO

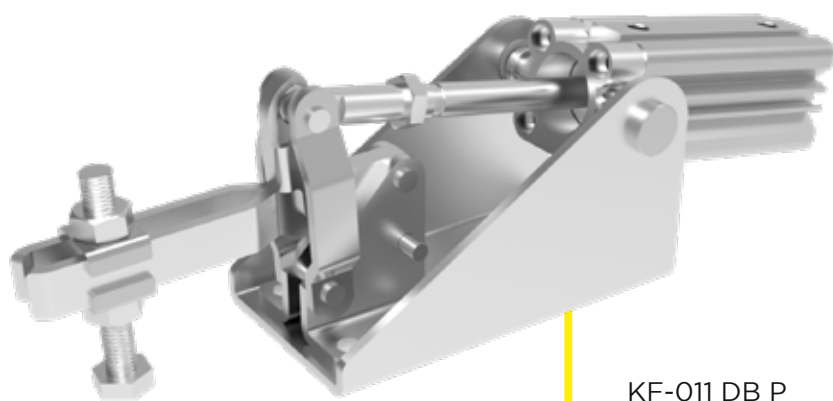

KF-011 DB P

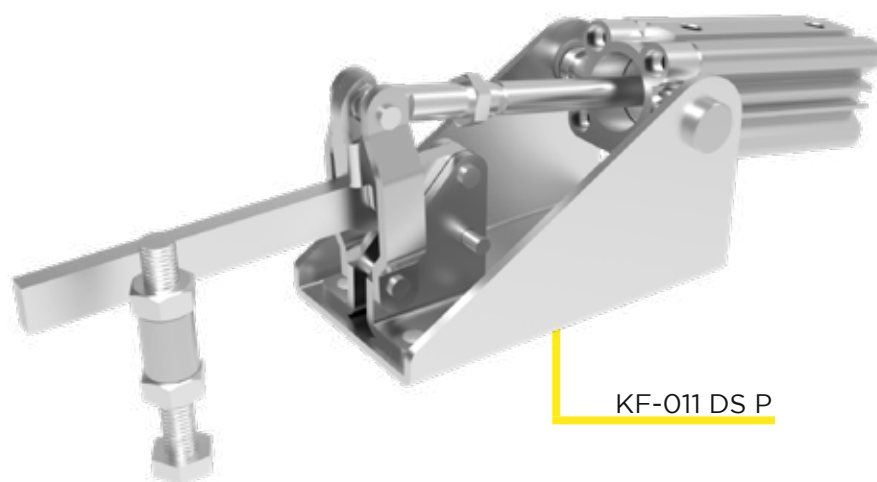
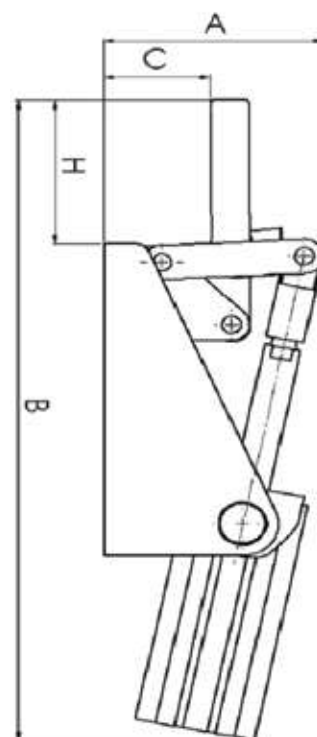

KF-011 DS P

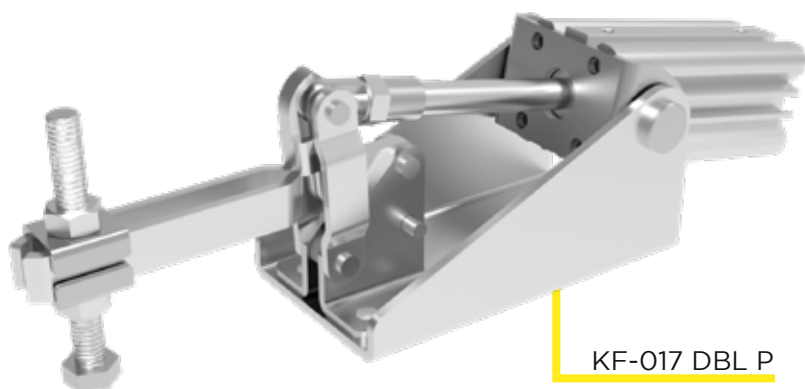
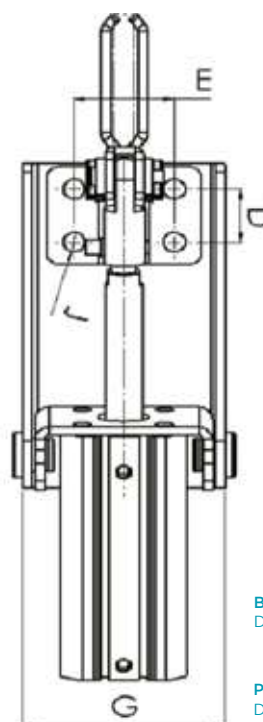

KF-017 DBL P

**BASES**  
D - Flanged Base

**HASTES**  
B - U - Bar  
S - Solid Bar  
L - Long U-Bar

**PIES**  
D - Doblado

**BRAZO**  
B - EN "U"  
S - Solido  
L - Largo

REFERENCE	RETENTION FORCE KGf (LBF)	A (IN)	B (IN)	C (IN)	D (IN)	E (IN)	G (IN)	H (IN)	J (IN)	ROSCA CIL	OPENING ANGLE	SPINDLE	WEIGHT KG (LB)
Referencia	Fuerza Retención Kgf (lbf)									Rosca Cil	Angulo de Apertura	Tornillo	Peso
KF-012 DB P	90 (198)	53 (2,09)	235 (9,25)	26 (1,02)	12,7 (0,50)	27 (1,06)	50 (1,97)	42 (1,65)	5,6 (0,22)	1/8 in NPT	70	M6	0,630 (1,386)
KF-017 DB P	170 (374)	72 (2,83)	238 (9,37)	35 (1,38)	19 (0,75)	32 (1,26)	64 (2,52)	53 (2,09)	7,0 (0,28)	M5	100	M8	1,510 (3,322)
KF-017 DBL P	150 (330)	72 (2,83)	268 (10,55)	35 (1,38)	19 (0,75)	32 (1,26)	64 (2,52)	83 (3,27)	7,0 (0,28)	M5	100	M8	1,530 (3,366)
KF-017 DS P	200 (440)	72 (2,83)	268 (10,55)	35 (1,38)	19 (0,75)	32 (1,26)	64 (2,52)	83 (3,27)	7,0 (0,28)	M5	100	M8	1,530 (3,366)
KF-011 DB P	280 (616)	97 (3,82)	328 (12,91)	47 (1,85)	32 (1,26)	44 (1,73)	79 (3,11)	86 (3,39)	8,5 (0,33)	1/8 in NPT	100	M10	2,830 (6,226)
KF-011 DBL P	250 (550)	97 (3,82)	354 (13,94)	47 (1,85)	32 (1,26)	44 (1,73)	79 (3,11)	112 (4,41)	8,5 (0,33)	1/8 in NPT	100	M10	2,860 (6,292)
KF-011 DS P	300 (660)	97 (3,82)	354 (13,94)	47 (1,85)	32 (1,26)	44 (1,73)	79 (3,11)	112 (4,41)	8,5 (0,33)	1/8 in NPT	100	M10	2,850 (6,270)
KF-111 DB P	680 (1496)	119 (4,69)	393 (15,47)	55 (2,17)	32 (1,26)	45 (1,77)	89,5 (3,52)	100 (3,94)	8,5 (0,33)	1/8 in NPT	100	M10	4,700 (10,340)
KF-111 DS P	700 (1540)	119 (4,69)	428 (16,85)	55 (2,17)	32 (1,26)	45 (1,77)	89,5 (3,52)	145 (5,71)	8,5 (0,33)	1/8 in NPT	100	M10	4,700 (10,340)
KF-111 DBL P	650 (1433)	119 (4,69)	393 (15,47)	55 (2,17)	32 (1,26)	45 (1,77)	89,5 (3,52)	145 (5,71)	8,5 (0,33)	1/8 in NPT	100	M10	3,550 (7,826)

# PNEUMATIC CLAMP PRENSA NEUMÁTICO

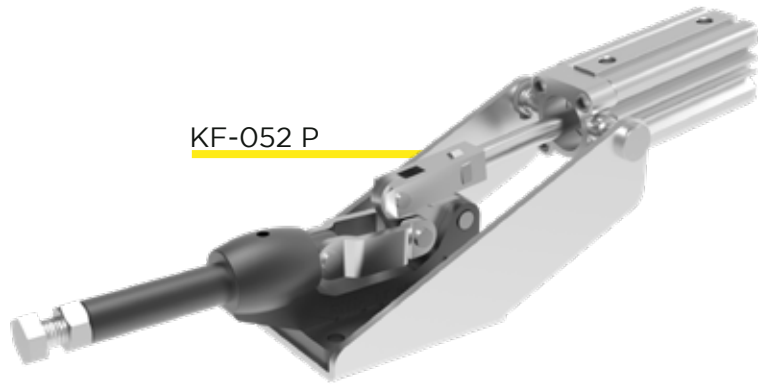

**KF-052 P**

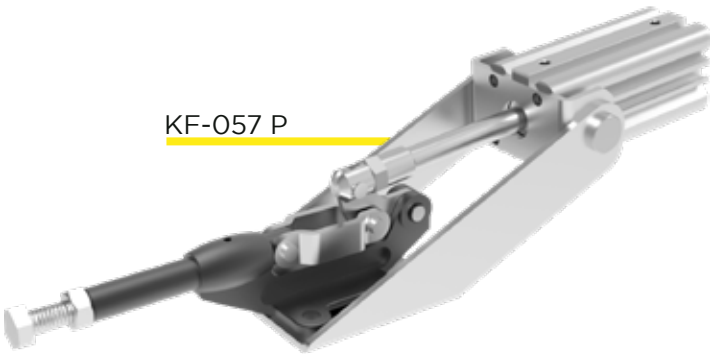
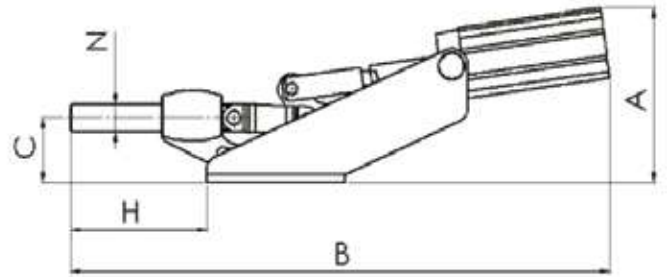

**KF-057 P**

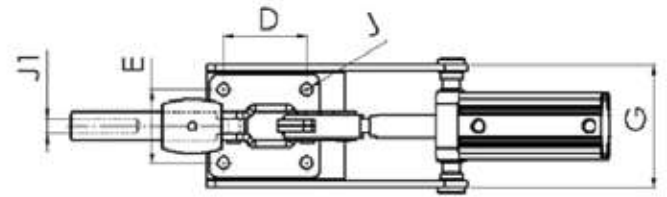

REFERENCE	RETENTION FORCE KGf (LBF)	A (IN)	B (IN)	C (IN)	D (IN)	E (IN)	G (IN)	H (IN)	J (IN)	J1 (IN)	N (IN)	ROSCA CIL	SPINDLE	WEIGHT KG (LB)
Referencia	Fuerza Retención Kgf (lbf)											Rosca Cil	Tornillo	Peso
KF-057 P	230 (506)	80 (3,15)	284 (11,18)	25 (0,98)	35 (1,38)	40 (1,57)	65 (2,56)	68 (2,68)	7 (0,28)	M8X1,25	12 (0,47)	M5	M12	1,500 (3,300)
KF-052 P	700 (1540)	119 (4,69)	390 (15,35)	44 (1,73)	60 (2,36)	50 (1,97)	83,5 (3,29)	99 (3,90)	8,5 (0,33)	M12X1,75	19 (0,75)	1/8 in NPT	M12	3,700 (8,140)

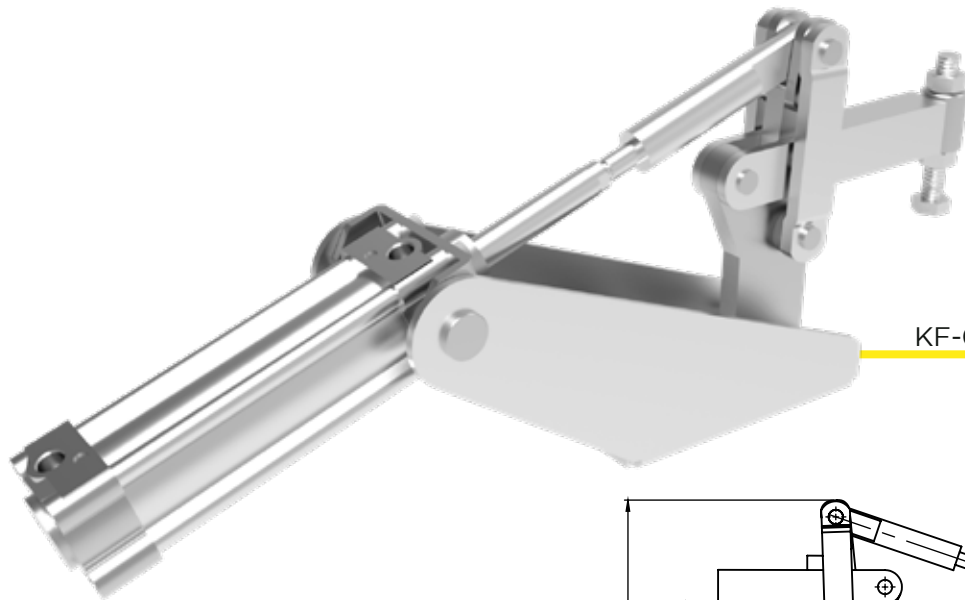

**KF-066 TS P**

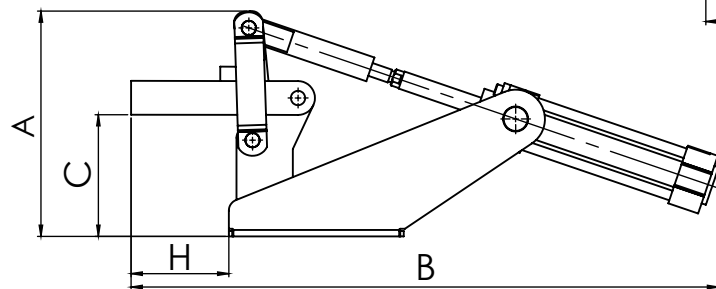
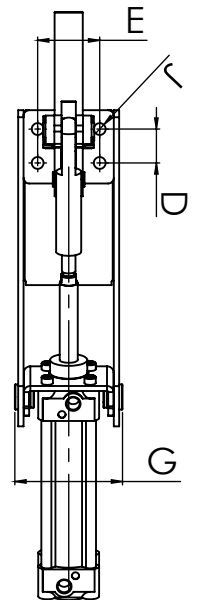

- BASES**    **BAR**  
T - Base T    S - Solid Bar
- PIES**    **BRAZO**  
T - Pies T    S - Solido

REFERENCE	RETENTION FORCE KGf (LBF)	A (IN)	B (IN)	C (IN)	D (IN)	E (IN)	G (IN)	H (IN)	J (IN)	ROSCA CIL	OPENING ANGLE	SPINDLE	WEIGHT KG (LB)
Referencia	Fuerza Retención Kgf (lbf)									Rosca Cil	Angulo de Apertura	Tornillo	Peso
KF-066 TS P	1400 (3080)	200 (7,87)	521 (20,51)	108 (4,25)	30 (1,18)	55 (2,17)	95,5 (3,76)	87 (3,43)	10,5 (0,41)	1/8 in NPT	55	M12	7,700 (16,940)



# PNEUMATIC CLAMP PRENSA NEUMÁTICO



**KF-019 DS P**

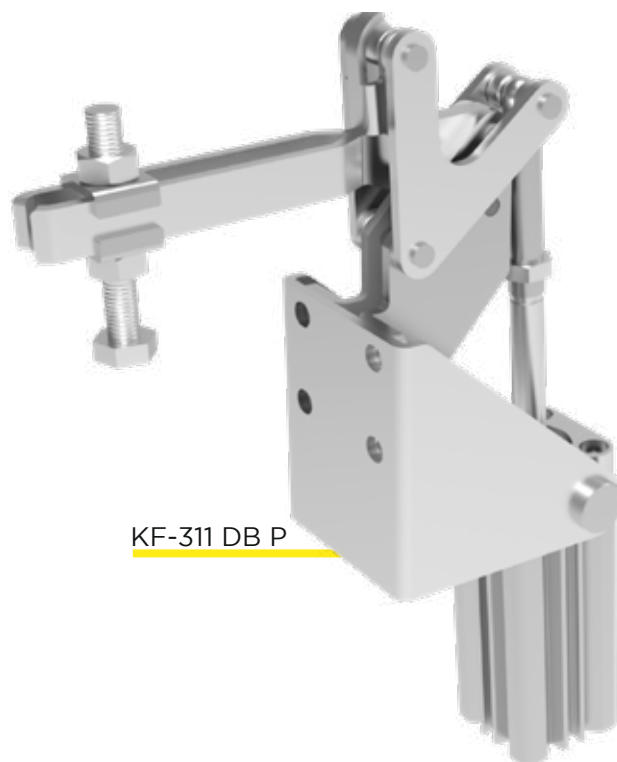

**KF-311 DB P**

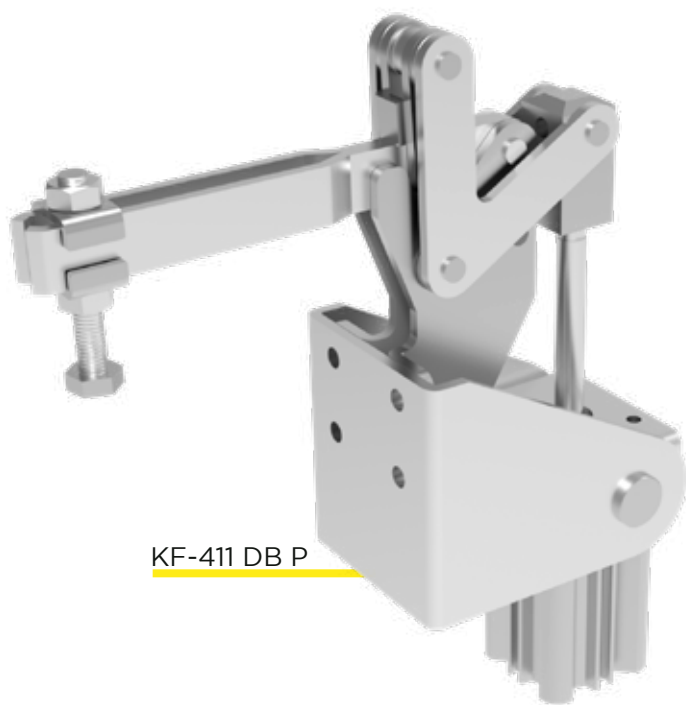

**KF-411 DB P**

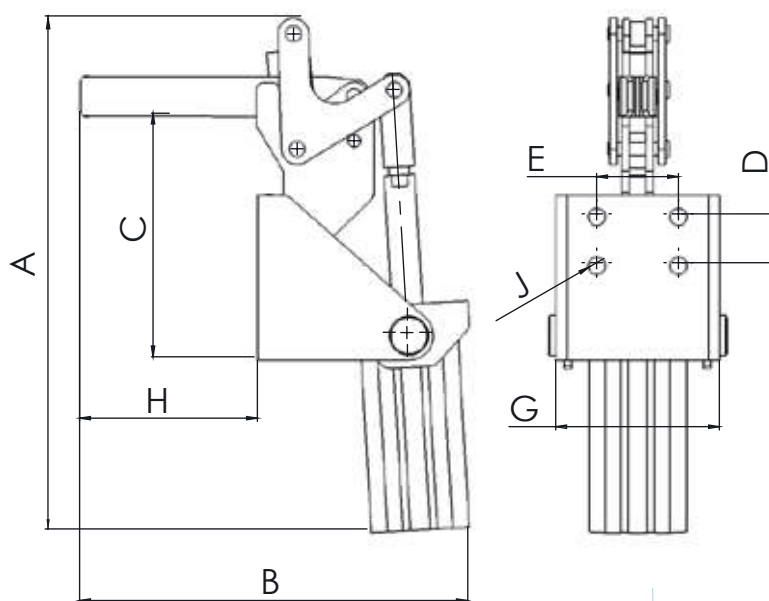

**BASES**  
D - Dobrada

**HASTES**  
B - Bifurcada  
S - Sólida

**PIES**  
D - Doblado

**BRAZO**  
B - em "U"  
S - Solido

REFERENCE	RETENTION FORCE KGf (LBF)	A (IN)	B (IN)	C (IN)	D (IN)	E (IN)	G (IN)	H (IN)	J (IN)	ROSCA CIL	OPENING ANGLE	SPINDLE WEIGHT KG (LB)
Referencia	Fuerza Retención Kgf (lbf)									Rosca Cil	Angulo de Apertura	Tornillo Peso
KF-019 DB P	250 (550)	210 (8,27)	159 (6,26)	97 (3,82)	20 (0,79)	33,5 (1,32)	67 (2,64)	73 (2,87)	7,0 (0,28)	M5	100	M8 1.600 (3,520)
KF-019 DS P	280 (616)	210 (8,27)	159 (6,26)	97 (3,82)	20 (0,79)	33,5 (1,32)	67 (2,64)	73 (2,87)	7,0 (0,28)	M5	100	M8 1.600 (3,520)
KF-311 DB P	250 (550)	282 (11,10)	216 (8,50)	130 (5,12)	32 (1,26)	44 (1,73)	75 (2,95)	102 (4,02)	8,5 (0,33)	1/8 in NPT	100	M10 2.830 (6,226)
KF-311 DS P	300 (660)	282 (11,10)	216 (8,50)	130 (5,12)	32 (1,26)	44 (1,73)	75 (2,95)	102 (4,02)	8,5 (0,33)	1/8 in NPT	100	M10 2.800 (6,160)
KF-411 DB P	650 (1430)	295 (11,61)	256 (10,08)	156 (6,14)	32 (1,26)	45 (1,77)	90 (3,54)	128 (5,04)	8,5 (0,33)	1/8 in NPT	100	M10 4.800 (10,560)
KF-411 DS P	700 (1540)	295 (11,61)	256 (10,08)	156 (6,14)	32 (1,26)	45 (1,77)	90 (3,54)	128 (5,04)	8,5 (0,33)	1/8 in NPT	100	M10 4.800 (10,560)

# PNEUMATIC CLAMP PRENSA NEUMÁTICO

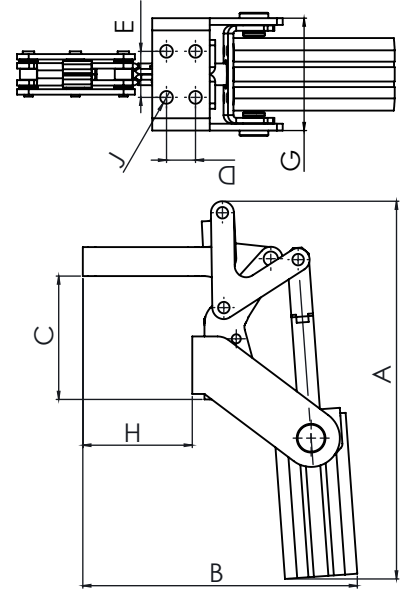
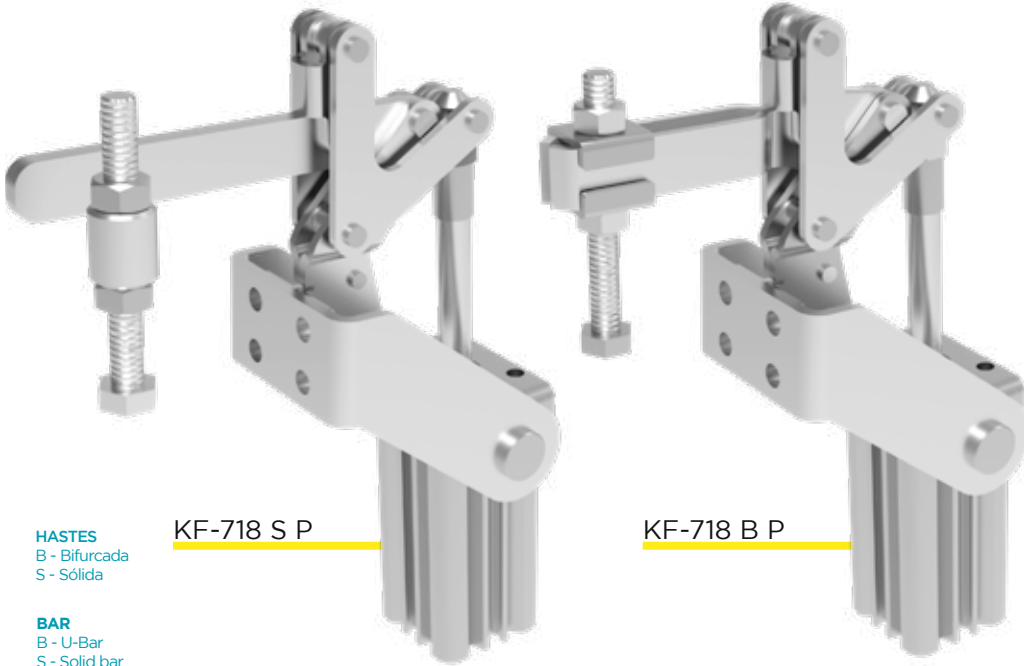

**HASTES**  
B - Bifurcada  
S - Sólida

**BAR**  
B - U-Bar  
S - Solid bar

**KF-718 S P**

**KF-718 B P**

REFERENCE	RETENTION FORCE KGf (LBF)	A (IN)	B (IN)	C (IN)	D (IN)	E (IN)	G (IN)	H (IN)	J (IN)	ROSCA CIL	SPINDLE	WEIGHT KG (LB)
Referencia	Fuerza Retención Kgf (lbf)									Rosca Cil	Tornillo	Peso
KF- 718 B P	200 (440)	203 (7,99)	152 (5,98)	68 (2,68)	16 (0,63)	25,4 (1,00)	62 (2,44)	60,4 (2,38)	7,0 (0,28)	M6	M6	1,500 (3,300)
KF- 718 S P	200 (440)	203 (7,99)	169 (6,65)	68 (2,68)	16 (0,63)	25,4 (1,00)	62 (2,44)	78 (3,07)	7,0 (0,28)	M6	M6	1,500 (3,300)

# POWER CLAMP PRENSA NEUMÁTICO PESADO

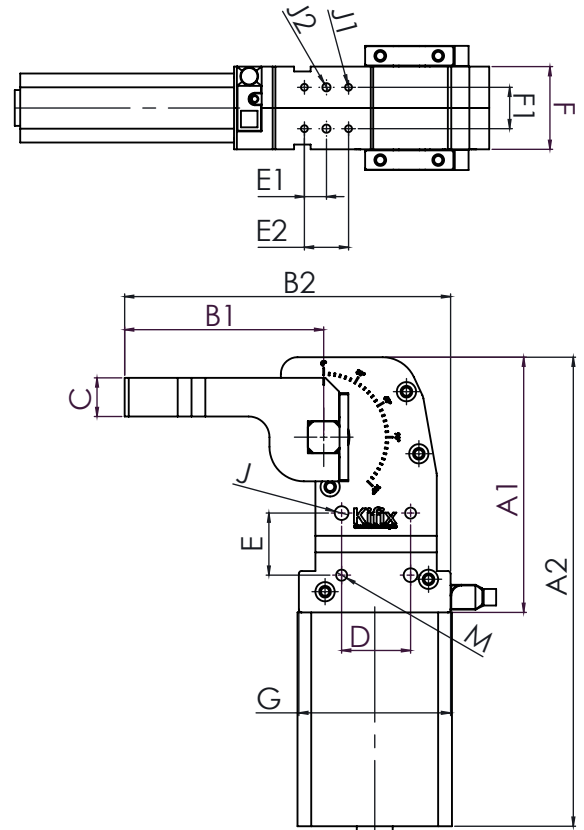
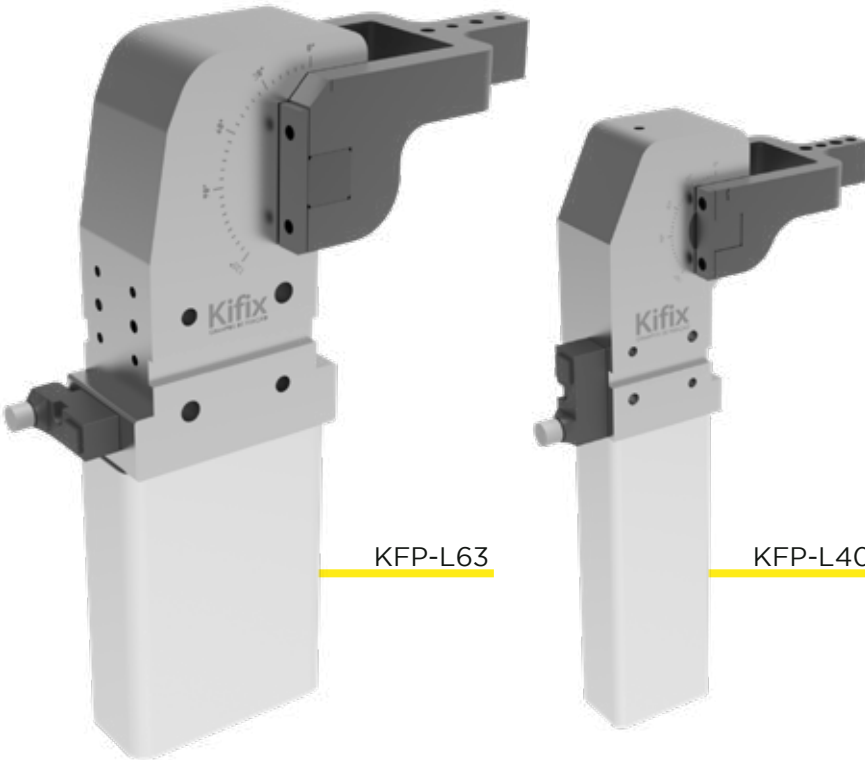

**KFP-L63**

**KFP-L40**

REFERENCE	RETENTION FORCE KGf (LBF)	OPENING ANGLE	A1 (IN)	A2 (IN)	B1 (IN)	B2 (IN)	C (IN)	D (IN)	D1 (IN)	E (IN)	E1 (IN)	E2 (IN)	F (IN)	F1 (IN)	G (IN)	J (IN)	J1 (IN)	J2 (IN)	M (IN)	WEIGHT KG (LB)
Referencia	Fuerza Retención Kgf (lbf)	Angulo de Apertura																		Peso
KFP-L40	400 (880)	0°-135°	146 (5,75)	325 (12,80)	110 (4,33)	170 (6,69)	22 (0,87)	35 (1,38)	25 (0,98)	25 (0,98)	-	20 (0,79)	48 (1,89)	24 (0,94)	65 (2,56)	6 (0,24)	M6	-	M6	6,000 (13,200)
KFP-L63	1100 (2420)	0°-135°	185 (7,28)	340 (13,39)	144 (5,67)	236 (9,29)	28 (1,10)	50 (1,97)	30 (1,18)	45 (1,77)	16 (0,63)	32 (1,26)	60 (2,36)	30 (1,18)	110 (4,33)	10 (0,39)	M6	6 (0,24)	M10	6,500 (14,300)

# HINGE BISAGRAS

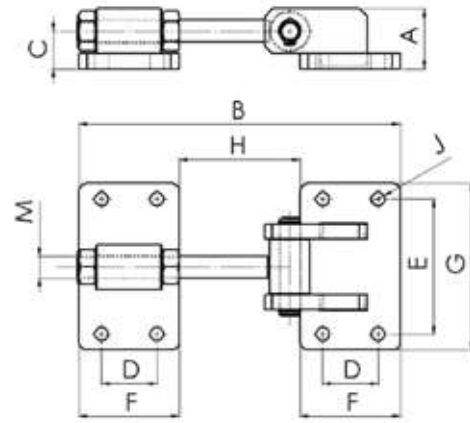
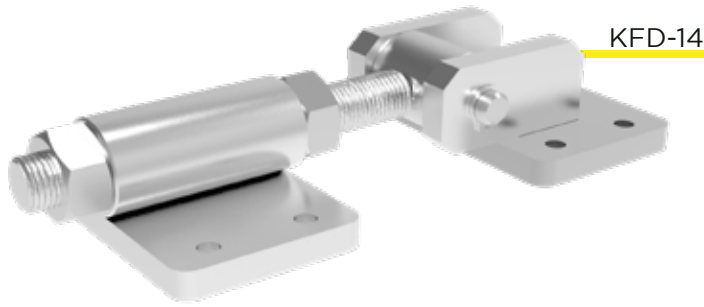

REFERENCE	RETENTION FORCE KGF (LBF)	A (IN)	B (IN)	C (IN)	D (IN)	E (IN)	F (IN)	G (IN)	H (IN)	J (IN)	M (IN)	WEIGHT KG (LB)
Referencia	Fuerza Retención Kgf (lbf)											Peso
KFT-10	900 (1980)	40 (1,57)	23 (0,91)	60 (2,36)	9,5 (0,37)	38 (1,50)	82 (3,23)	12,7 (0,50)	11 (0,43)	M10x1,50	M8x1,25	1,040 (2,288)
KFT-14	1400 (3080)	40 (1,57)	25 (0,98)	70 (2,76)	9,5 (0,37)	38 (1,50)	90 (3,54)	16 (0,63)	12,5 (0,49)	M14x2,00	M14x2,00	1,370 (3,014)

# LATCH PESTITILLO

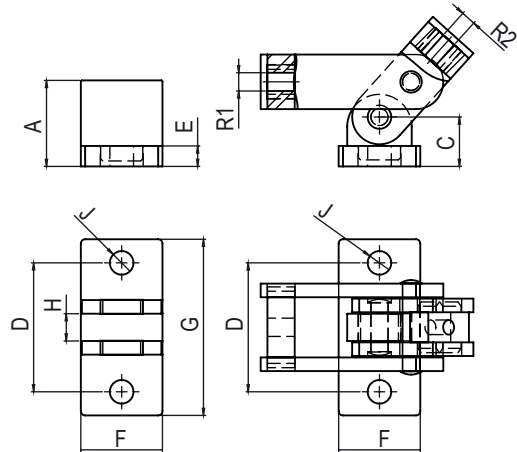
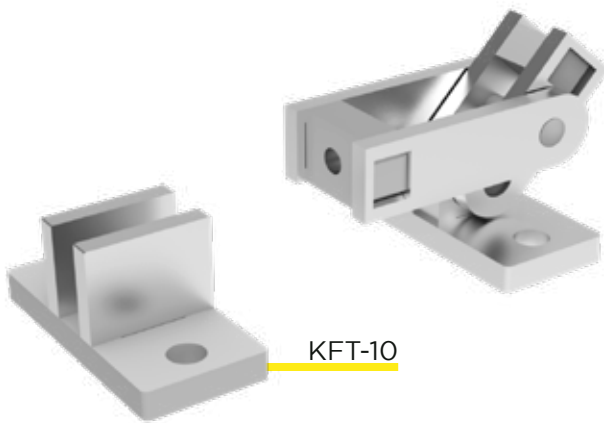

REFERENCE	RETENTION FORCE KGF (LBF)	A (IN)	C (IN)	D (IN)	E (IN)	F (IN)	G (IN)	H (IN)	J (IN)	R1 (IN)	R2 (IN)	WEIGHT KG (LB)
Referencia	Fuerza Retención Kgf (lbf)											Peso
KFT-10	900 (1980)	40 (1,57)	23 (0,91)	60 (2,36)	9,5 (0,37)	38 (1,50)	82 (3,23)	12,7 (0,50)	11 (0,43)	M10x1,50	M8x1,25	1,040 (2,288)
KFT-14	1400 (3080)	40 (1,57)	25 (0,98)	70 (2,76)	9,5 (0,37)	38 (1,50)	90 (3,54)	16 (0,63)	12,5 (0,49)	M14x2,00	M14x2,00	1,370 (3,014)

# SQUEEZE ACTION CLAMPS ALICATES

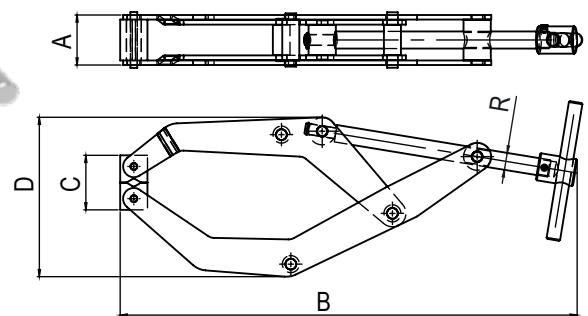
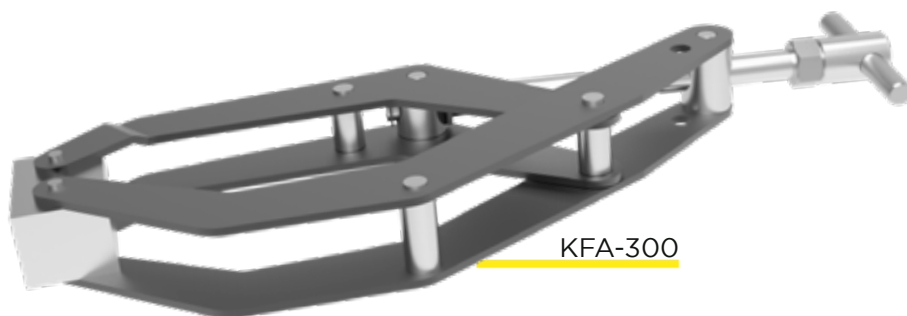

REFERENCE	RETENTION FORCE KGF (LBF)	A (IN)	B (IN)	C (CLOSED) (IN)	C (OPEN) (IN)	D (IN)	ROSCA CIL	WEIGHT KG (LB)
Referencia	Fuerza Retención Kgf (lbf)			Fechado	Abierto		Rosca Cil	Peso
KFA-300	150 (330)	47 (1,85)	432 (17,01)	60 (2,36)	300 (11,81)	148 (5,83)	M16x2,00	2,750 (6,050)

# SQUEEZE ACTION CLAMP ALICATES

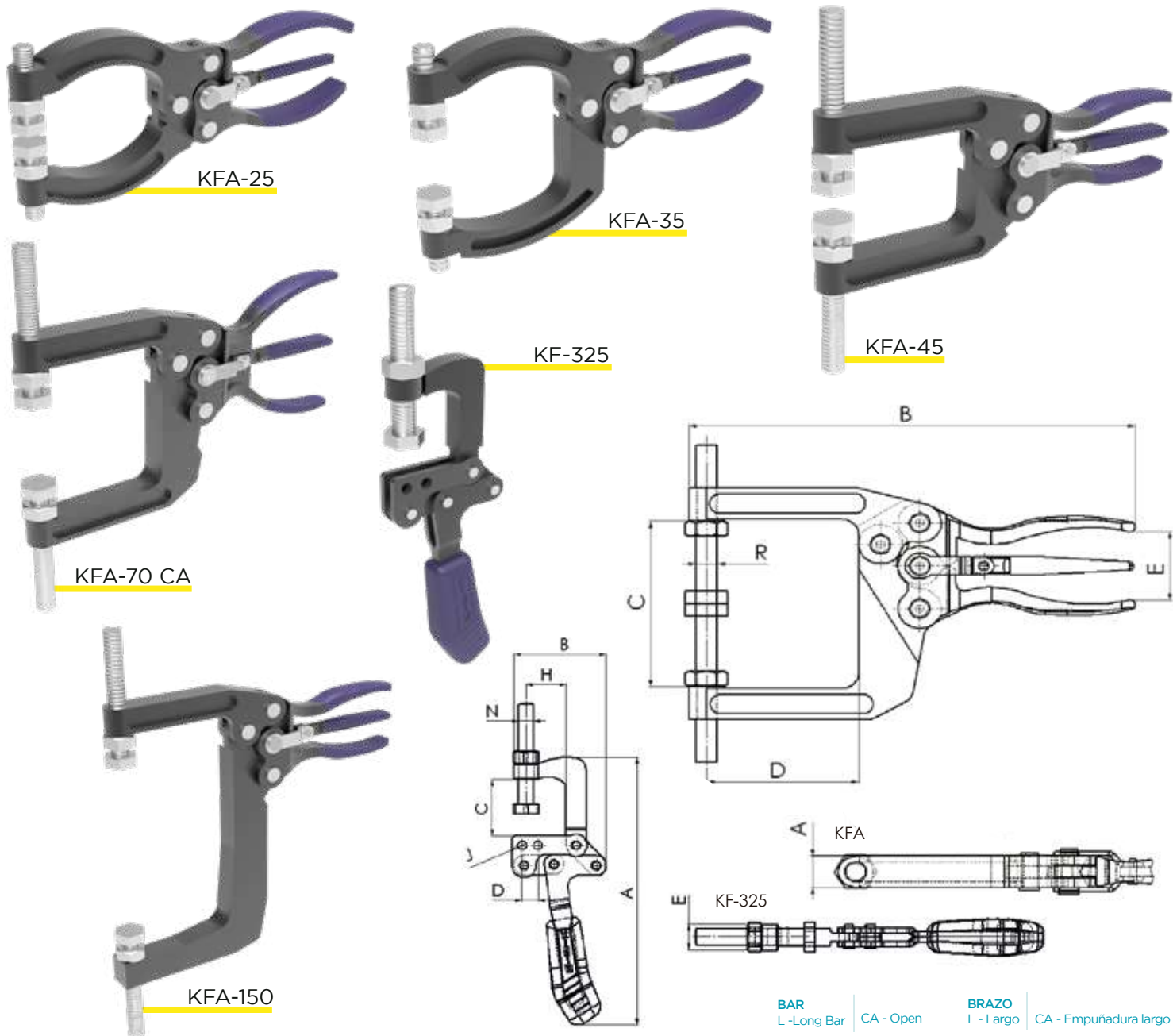

REFERENCE	RETENTION FORCE KGf (LBF)	A (IN)	B (IN)	C (IN)	D (IN)	E (IN)	H (IN)	J (IN)	N (IN)	OPENING ANGLE	SPINDLE	WEIGHT KG (LB)
Referencia	Fuerza Retención Kgf (lbf)									Angulo de Apertura	Tornillo	Peso
KF -325	360 (793)	212 (8,35)	73 (2,87)	45,3 (1,78)	12,7 (0,50)	19 (0,75)	32 (1,26)	6,8 (0,27)	M12X1,75	93	M12	0,575 (1,265)

REFERENCE	RETENTION FORCE KGf (LBF)	A (IN)	B (IN)	C (IN)	D (IN)	E (IN)	R (IN)	SPINDLE	WEIGHT KG (LB)
Referencia	Fuerza Retención Kgf (lbf)							Tornillo	Peso
KFA-25	250 (550)	10 (0,39)	140 (5,51)	28 (1,10)	46,5 (1,83)	21,4 (0,84)	M6X1,00	M6	0,240 (0,528)
KFA-35	250 (550)	10 (0,39)	140 (5,51)	45 (1,77)	46,5 (1,83)	21,4 (0,84)	M6X1,00	M6	0,250 (0,550)
KFA-45	900 (1980)	16 (0,63)	205 (8,07)	53 (2,09)	70 (2,76)	35,2 (1,39)	M10X1,50	M10	0,890 (1,958)
KFA-45 CA	900 (1980)	16 (0,63)	205 (8,07)	53 (2,09)	70 (2,76)	80,2 (3,16)	M10X1,50	M10	1,010 (2,222)
KFA-70	900 (1980)	16 (0,63)	205 (8,07)	85 (3,35)	70 (2,76)	35,2 (1,39)	M10X1,50	M10	0,980 (2,156)
KFA-70 CA	900 (1980)	16 (0,63)	205 (8,07)	85 (3,35)	70 (2,76)	80,2 (3,16)	M10X1,50	M10	1,100 (2,420)
KFA-90	900 (1980)	16 (0,63)	205 (8,07)	93 (3,66)	71,5 (2,81)	35,2 (1,39)	M10X1,50	M10	1,120 (2,464)
KFA-90 CA	900 (1980)	16 (0,63)	205 (8,07)	93 (3,66)	71,5 (2,81)	80,2 (3,16)	M10X1,50	M10	1,240 (2,728)
KFA-90 L	250 (550)	16 (0,63)	305 (12,01)	93 (3,66)	171,5 (6,75)	35,2 (1,39)	M10X1,50	M10	1,490 (3,278)
KFA-100	900 (1980)	16 (0,63)	205 (8,07)	103 (4,06)	71,5 (2,81)	35,2 (1,39)	M10X1,50	M10	1,150 (2,530)
KFA-100 CA	900 (1980)	16 (0,63)	205 (8,07)	103 (4,06)	71,5 (2,81)	80,2 (3,16)	M10X1,50	M10	1,270 (2,794)
KFA-150	900 (1980)	16 (0,63)	205 (8,07)	153 (6,02)	71,5 (2,81)	35,2 (1,39)	M10X1,50	M10	1,290 (2,838)
KFA-150 CA	900 (1980)	16 (0,63)	205 (8,07)	153 (6,02)	71,5 (2,81)	85,2 (3,35)	M10X1,50	M10	1,410 (3,102)



KF-AL

**WE PRODUCE CLAMPS WITH HANDLE  
ACCORDING TO CUSTOMER NEEDS**

PRODUCIMOS ABRAZADERAS CON MANGO  
SEGÚN LAS NECESIDADES DEL CLIENTE

REFERENCE	A (IN)	B (IN)	C (IN)	D (IN)	E (IN)	J (IN)	WEIGHT KG (LB)
Referencia							Peso
KF-AL	174 (6,85)	134 (5,28)	18 (6,85)	26 (1,02)	7,5 (0,30)	6,4 (0,25)	0,460 (1,012)

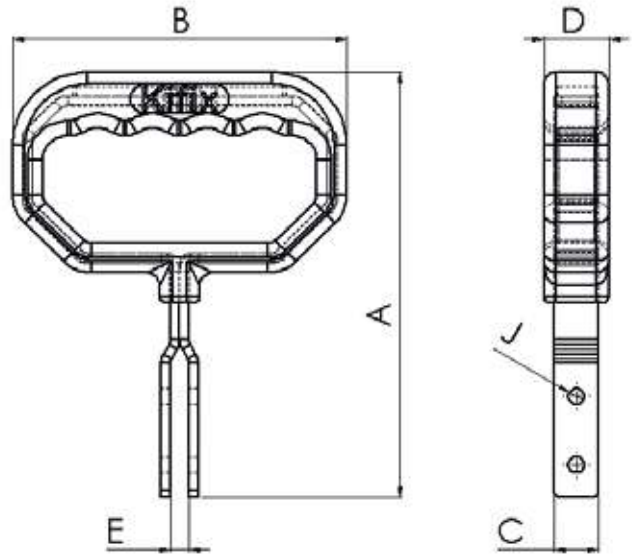

## SPINDLE TORNILLO DE APRIETE

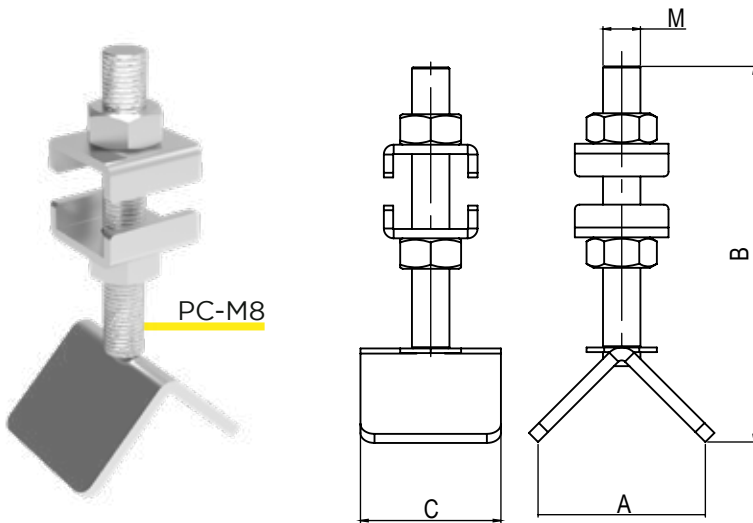

PC-M8

REFERENCE	A (IN)	B (IN)	C (IN)	M (IN)
Referencia				
PC-M6	36 (1,42)	80 (3,15)	30 (1,18)	M6
PC-M8	36 (1,42)	100 (3,94)	30 (1,18)	M8
PC-M10	36 (1,42)	91 (3,58)	30 (1,18)	M10
PF-M6 35x40	16 (0,63)	35 (1,38)	40 (1,57)	M6
PF-M6 51x40	16 (0,63)	51 (2,01)	40 (1,57)	M6
PF-M6 51x100	16 (0,63)	51 (2,01)	100 (3,94)	M6
PF-M6 66x100	16 (0,63)	66 (2,60)	100 (3,94)	M6
PF-M8	16 (0,63)	77 (3,03)	100 (3,94)	M8
PF-M10	16 (0,63)	77 (3,03)	100 (3,94)	M10

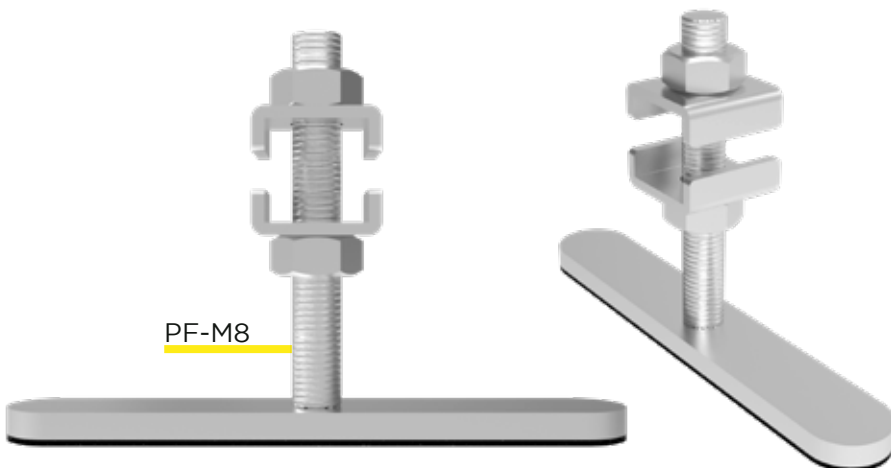

PF-M8

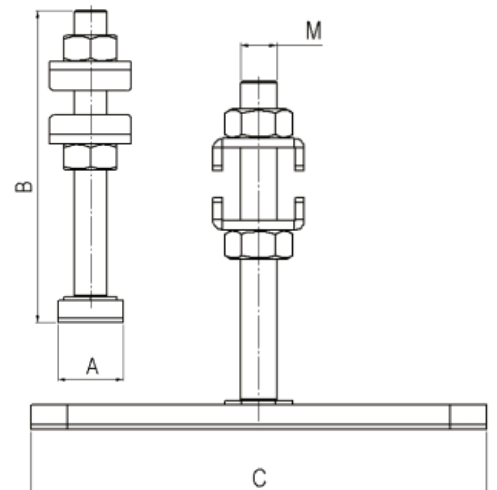



# SPINDLE TORNILLO DE APRIETE

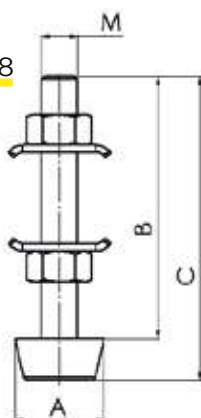
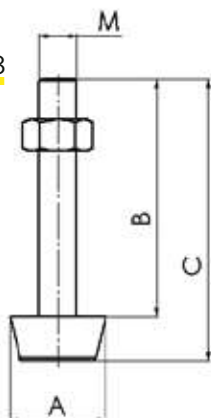
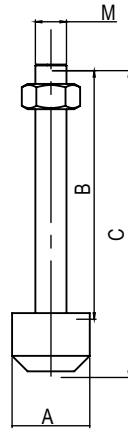
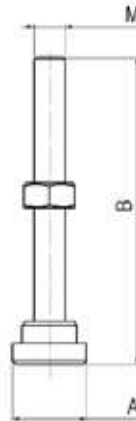
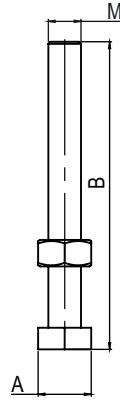

REFERENCE	A (IN)	B (IN)	M (IN)
PP-M6	10 (0,39)	49 (1,93)	M6
PP-M8	13 (0,51)	45 (1,77)	M8
PP-M10	17 (0,67)	51 (2,01)	M10
PP-M12	19 (0,75)	47 (1,85)	M12
PP-M16	24 (0,94)	79 (3,11)	M16
PS-M6	10 (0,39)	64 (2,52)	M6
PS-M8	13 (0,51)	75 (2,95)	M8
PS-M10	17 (0,67)	77 (3,03)	M10
PSB-M6	10 (0,39)	64 (2,52)	M6
PSB-M8	13 (0,51)	75 (2,95)	M8
PSB-M10	17 (0,67)	77 (3,03)	M10
PSB-M12	19 (0,75)	87 (3,43)	M12

REFERENCE	A (IN)	B (IN)	M (IN)
PA-M6	19 (0,75)	67 (2,64)	M6
PA-M8	19 (0,75)	80 (3,15)	M8
PA-M10	19 (0,75)	80 (3,15)	M10
PA-M12	32 (1,26)	95 (3,74)	M12
PA-M16	32 (1,26)	118 (4,65)	M16
ARP-M6	19 (0,75)	67 (2,64)	M6
ARP-M8	19 (0,75)	80 (3,15)	M8
ARP-M10	19 (0,75)	80 (3,15)	M10
ARB-M6	19 (0,75)	67 (2,64)	M6
ARB-M8	19 (0,75)	80 (3,15)	M8
ARB-M10	19 (0,75)	80 (3,15)	M10
ARB-M16	32 (1,26)	118 (4,65)	M16

REFERENCE	A (IN)	B (IN)	C (IN)	M (IN)
PB-M6	15 (0,59)	57 (2,24)	69 (2,72)	M6
PB-M8	18,5 (0,73)	63 (2,48)	78 (3,07)	M8
PB-M10	23 (0,91)	63 (2,48)	82 (3,23)	M10
BRP-M6	15 (0,59)	57 (2,24)	69 (2,72)	M6
BRP-M8	18,5 (0,73)	63 (2,48)	78 (3,07)	M8
BRP-M10	23 (0,91)	63 (2,48)	82 (3,23)	M10
BRB-M6	15 (0,59)	57 (2,24)	69 (2,72)	M6
BRB-M8	18,5 (0,73)	63 (2,48)	78 (3,07)	M8
BRB-M10	23 (0,91)	63 (2,48)	82 (3,23)	M10
BAP-M6	16 (0,63)	24 (0,94)	31 (1,22)	M6

REFERENCE	A (IN)	B (IN)	C (IN)	M (IN)
PBC-M4X20	11,2 (0,44)	19 (0,75)	24 (0,94)	M4
PBC-M4X30	11,2 (0,44)	29 (1,14)	34 (1,34)	M4
PBC-M5X25	12,7 (0,50)	25 (0,98)	30 (1,18)	M5
PBC-M5X30	12,7 (0,50)	30 (1,18)	35 (1,38)	M5
PBC-M5X35	12,7 (0,50)	35 (1,38)	40 (1,57)	M5
PBC-M6X30	15,8 (0,62)	29 (1,14)	36 (1,42)	M6
PBC-M6X40	15,8 (0,62)	39 (1,54)	46 (1,81)	M6
PBC-M6X45	15,8 (0,62)	44 (1,73)	51 (2,01)	M6

REFERENCE	A (IN)	B (IN)	C (IN)	M (IN)
BRPC-M5X25	12,7 (0,50)	25 (0,98)	30 (1,18)	M5
BRPC-M5X30	12,7 (0,50)	30 (1,18)	35 (1,38)	M5
BRPC-M5X35	12,7 (0,50)	35 (1,38)	40 (1,57)	M5
BRPC-M6X30	15,8 (0,62)	29 (1,14)	36 (1,42)	M6
BRPC-M6X40	15,8 (0,62)	39 (1,54)	46 (1,81)	M6
BRPC-M6X45	15,8 (0,62)	44 (1,73)	51 (2,01)	M6

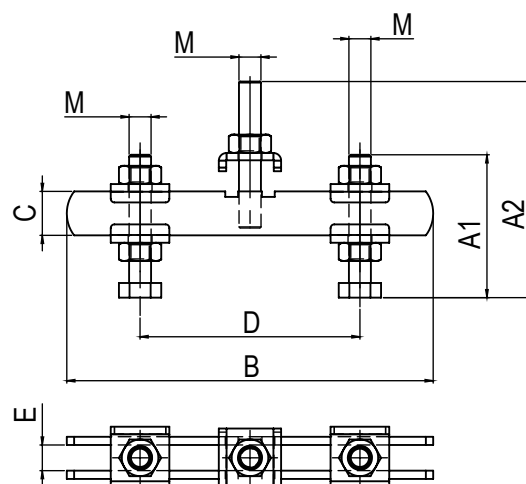
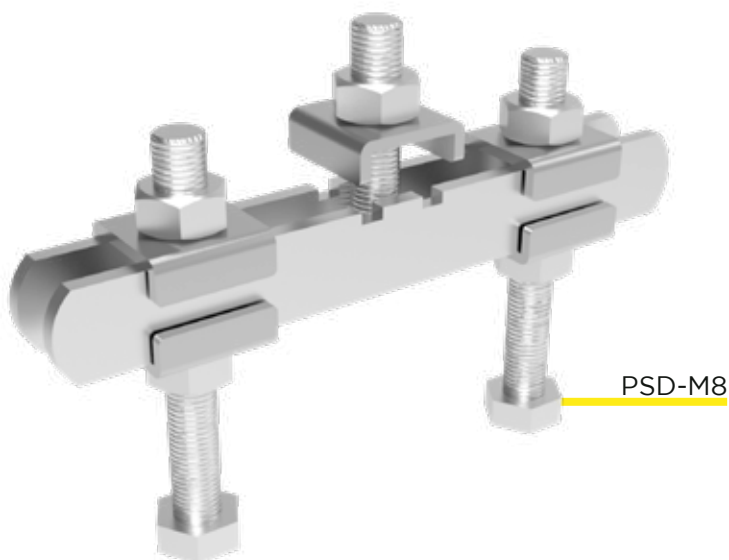

REFERENCE Referencia	A1 (IN)	A2 (IN)	B (IN)	C (IN)	D MÍN (IN)	D MÁX (IN)	E (IN)	M (IN)
PSD-M6	49 (1,93)	59 (2,32)	100 (3,94)	12 (0,47)	30 (1,18)	80 (3,15)	7 (0,28)	M6
PSD-M8	75 (2,95)	86 (3,39)	120 (4,72)	15 (0,59)	35 (1,38)	92 (3,62)	9 (0,35)	M8
PSD-M10	76 (2,99)	90 (3,54)	180 (7,09)	20 (0,79)	42 (1,65)	148 (5,83)	11 (0,43)	M10

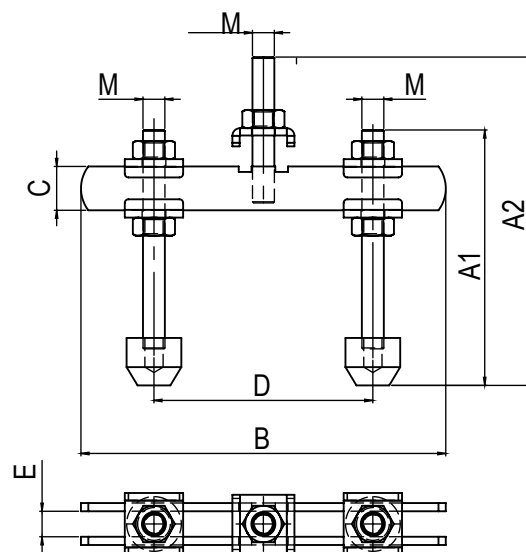
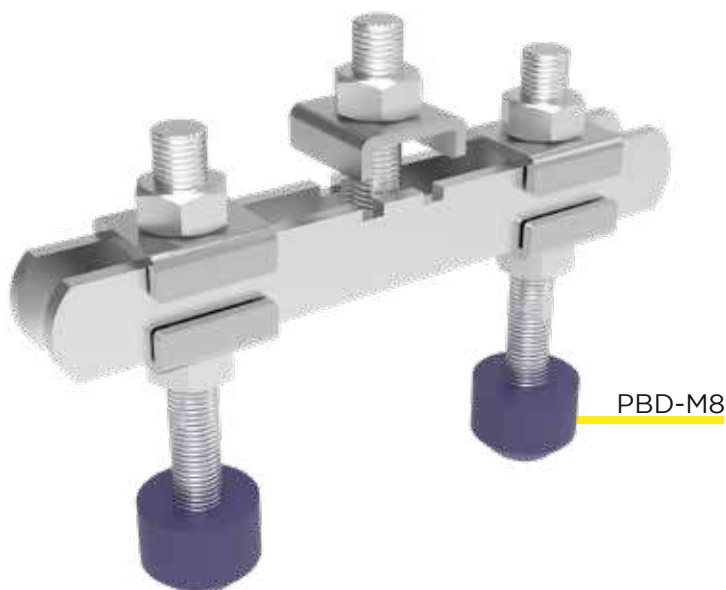

REFERENCE Referencia	A1 (IN)	A2 (IN)	B (IN)	C (IN)	D MÍN (IN)	D MÁX (IN)	E (IN)	M (IN)
PBD-M6	69 (2,72)	89 (3,50)	100 (3,94)	12 (0,47)	30 (1,18)	80 (3,15)	7 (0,28)	M6
PBD-M8	78 (3,07)	89 (3,50)	120 (4,72)	15 (0,59)	35 (1,38)	92 (3,62)	9 (0,35)	M8
PBD-M10	82 (3,23)	95 (3,74)	180 (7,09)	20 (0,79)	42 (1,65)	148 (5,83)	11 (0,43)	M10

## REFERENCE

PP	Hex Head Fully - Threaded
PS	Hex Head - Flanged Washers
PSB	Hex Head Bolt Retainer
PB	Flap - Tip Bonded Neoprene Cap
BRP	Flap - Tip Bonded Neoprene Cap - Flanged Washers
BRB	Flap - Tip Bonded Neoprene Cap - Bolt Retainer
PBC	Rubber cone spindle with nut
BRPC	Rubber cone spindle with washer
BAP	Flat - Tip Bonded Neoprene Cap - Ring
PA	Swivel Foot
ARP	Swivel Foot - Flanged Washers
ARB	Swivel Foot - Bolt Retainer
PC	Corner Foot - Flanged Washers
PF	Felt Foot - Flanged Washers
PBD	Flat - Tip Bonded Neoprene Cap - Double Piece
PSD	Hex Head - Fully Threaded - Double Piece

## SUBTITLE

## LEGENDA

Tornillo Hexagonal con Tuerca
Tornillo Hexagonal con Placas de Sujeción
Tornillo Hexagonal con Bujes
Tornillo con Pieza de Neoprene y Tuerca
Tornillo con Pieza de Neoprene y Placas de Sujeción
Tornillo con Pieza de Neoprene Bujes
Tornillo con Pieza de Neoprene y Tuerca, Cónica
Tornillo con Pieza de Neoprene y Placas de Sujeción, Cónica
Tornillo con Pieza de Neoprene y Arandela
Tornillo articulado con Tuerca
Tornillo Articulado Con Tuerca
Tornillo Articulado con Bujes
Tornillo Esquina con Placas de Sujeción
Tornillo con Feltro y Placas de Sujeción
Tornillo Doble con Pieza de Neoprene
Tornillo Doble Hexagonal

# ELEVATED BASE BASE ELEVADA

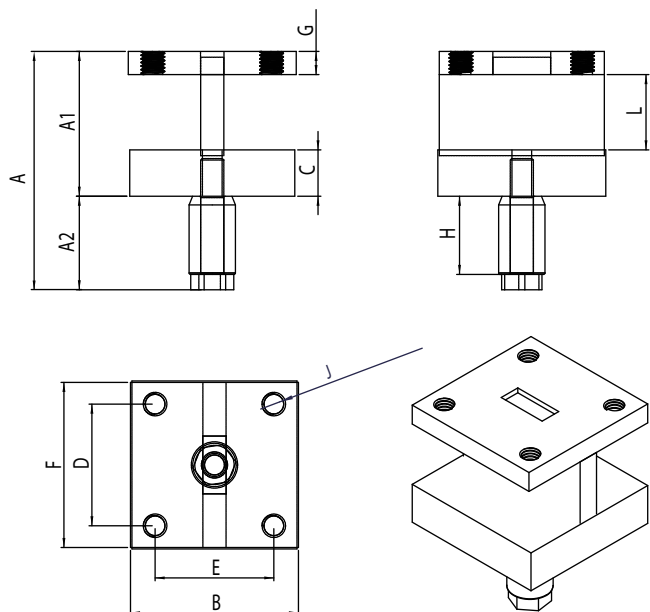

MS BE Ø 22 H50 - KF-532/528



MS BE Ø 22 H75 - KF-532/528

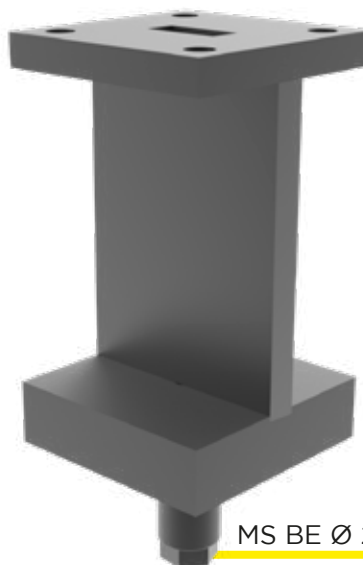

MS BE Ø 22 H100 - KF-532/528

MS - Welding table  
BE - Elevated base  
H - Height

MS - Mesas de soldadura  
BE - Base elevada  
H - Altura

REFERENCE	Referencia	A (IN)	A1 (IN)	A2 (IN)	B (IN)	C (IN)	D (IN)	E (IN)	F (IN)	G (IN)	H (IN)	J (IN)	L (IN)	WEIGHT KG (LB)
Peso														
MS BE Ø 16 H50 - KF-532/528		82,3 (3,24)	50 (1,96)	32,3 (1,27)	58 (2,28)	16 (0,62)	42 (1,65)	41 (1,61)	57 (2,24)	8 (0,31)	27 (1,06)	M8	26	0,76 (1,67)
MS BE Ø 22 H50 - KF-532/528		88,4 (3,48)	51 (1,96)	36,4 (1,43)	58 (2,28)	16 (0,62)	42 (1,65)	41 (1,61)	57 (2,24)	8 (0,31)	30 (1,18)	M8	26	0,82 (1,80)
MS BE Ø 28 H50 - KF-532/528		95,5 (3,75)	52 (1,96)	42,5 (1,67)	58 (2,28)	16 (0,62)	42 (1,65)	41 (1,61)	57 (2,24)	8 (0,31)	35 (1,37)	M8	26	0,91 (2,00)
MS BE Ø 16 H75 - KF-532/528		107,3 (4,22)	75 (2,95)	32,3 (1,27)	58 (2,28)	16 (0,62)	42 (1,65)	41 (1,61)	57 (2,24)	8 (0,31)	27 (1,06)	M8	51	0,85 (1,87)
MS BE Ø 22 H75 - KF-532/528		111,4 (4,38)	75 (2,95)	36,4 (1,43)	58 (2,28)	16 (0,62)	42 (1,65)	41 (1,61)	57 (2,24)	8 (0,31)	30 (1,18)	M8	51	0,914 (2,01)
MS BE Ø 28 H75 - KF-532/528		117,5 (4,62)	75 (2,95)	42,5 (1,67)	58 (2,28)	16 (0,62)	42 (1,65)	41 (1,61)	57 (2,24)	8 (0,31)	35 (1,37)	M8	51	0,995 (2,19)
MS BE Ø 16 H100 - KF-532/528		132,3 (5,20)	100 (3,93)	32,3 (1,27)	58 (2,28)	16 (0,62)	42 (1,65)	41 (1,61)	57 (2,24)	8 (0,31)	27 (1,06)	M8	78	0,942 (2,07)
MS BE Ø 22 H100 - KF-532/528		136,4 (5,37)	100 (3,93)	36,4 (1,43)	58 (2,28)	16 (0,62)	42 (1,65)	41 (1,61)	57 (2,24)	8 (0,31)	30 (1,18)	M8	78	1,005 (2,21)
MS BE Ø 28 H100 - KF-532/528		145,5 (5,72)	100 (3,93)	42,5 (1,67)	58 (2,28)	16 (0,62)	42 (1,65)	41 (1,61)	57 (2,24)	8 (0,31)	35 (1,37)	M8	78	1,085 (2,39)

# VARIABLE STROKE BASE BASE HUSILLO RÁPIDO

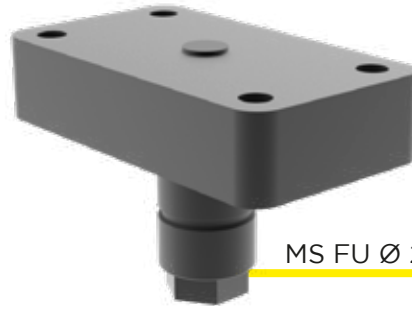
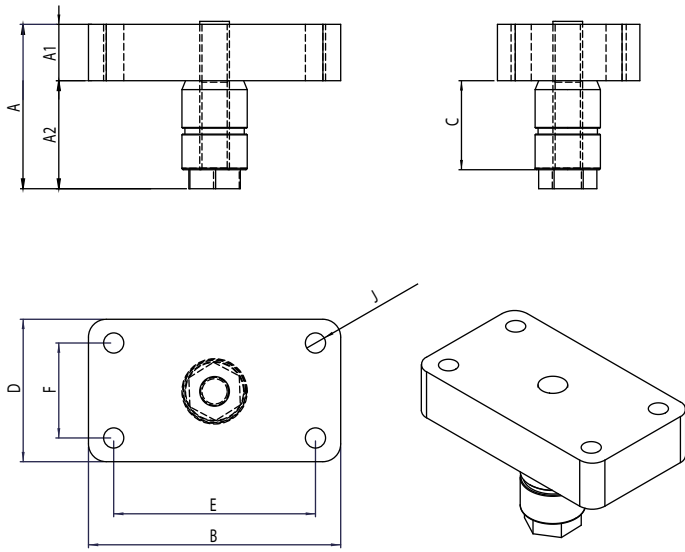

MS FU Ø 22 - KFRL-20

MS - Welding table MS - Mesa de soldadura  
FU - Variable Stroke FU - Husillo rápido

REFERENCE	Referencia	A (IN)	A1 (IN)	A2 (IN)	B (IN)	C (IN)	D (IN)	E (IN)	F (IN)	J (IN)	WEIGHT KG (LB)
											Peso
MS FU Ø 16 - KFRL-20		48,3 (1,90)	16 (0,62)	32,3 (1,27)	85 (3,34)	27 (1,06)	48 (1,88)	68 (2,67)	32 (1,25)	M8	0,542 (1,19)
MS FU Ø 22 - KFRL-20		55,4 (2,18)	19 (0,74)	36,4 (1,43)	85 (3,34)	30 (1,18)	48 (1,88)	68 (2,67)	32 (1,25)	M8	0,695 (1,53)
MS FU Ø 28 - KFRL-20		67,9 (2,67)	25,4 (1,00)	42,5 (1,67)	85 (3,34)	35 (1,37)	48 (1,88)	68 (2,67)	32 (1,25)	M9	0,954 (2,10)

# VERTICAL BASE BASE VERTICAL

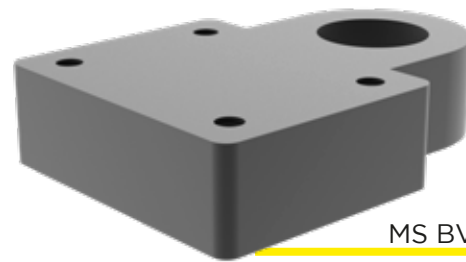
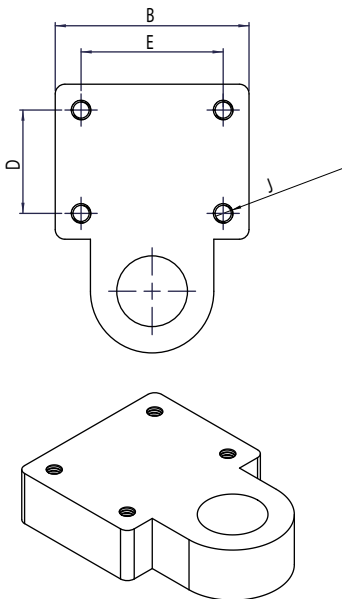

MS BV Ø 22 - KF-011

MS - Welding table MS - Mesa de soldadura  
BV - Vertical base BV - Base vertical

REFERENCE	A (IN)	B (IN)	C (IN)	D (IN)	E (IN)	J (IN)	WEIGHT KG (LB)
Referencia							Peso
MS BV Ø 16 - KF-011	83,2 (3,27)	60 (2,36)	16 (0,62)	32 (1,25)	44 (1,73)	M6	0,48 (1,05)
MS BV Ø 22 - KF-011	83,2 (3,27)	60 (2,36)	19 (0,74)	33 (1,25)	44 (1,73)	M6	0,538 (1,18)
MS BV Ø 28 - KF-011	83,2 (3,27)	60 (2,36)	25,4 (1,00)	34 (1,25)	44 (1,73)	M6	0,673 (1,48)
MS BV Ø 16 - KF-111	97,24 (3,82)	60 (2,36)	16 (0,62)	32 (1,25)	44 (1,73)	M8	0,63 (1,38)
MS BV Ø 22 - KF-111	97,24 (3,82)	60 (2,36)	19 (0,74)	33 (1,25)	44 (1,73)	M8	0,72 (1,58)
MS BV Ø 28 - KF-111	97,24 (3,82)	60 (2,36)	25,4 (1,00)	34 (1,25)	44 (1,73)	M8	0,96 (2,11)

# HORIZONTAL BASE BASE HORIZONTAL

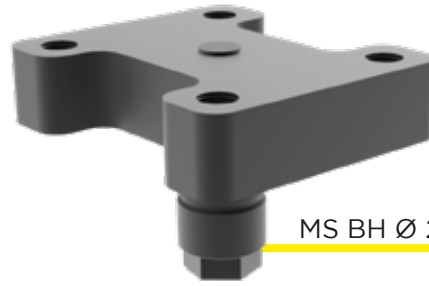
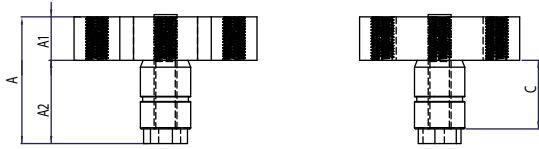

MS BH Ø 22 - KF-052

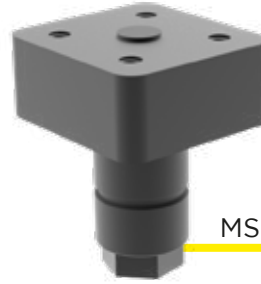
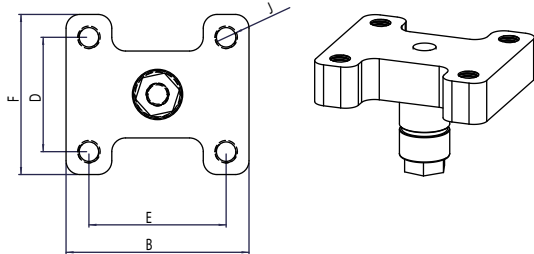

MS BH Ø 22 - KF-0521

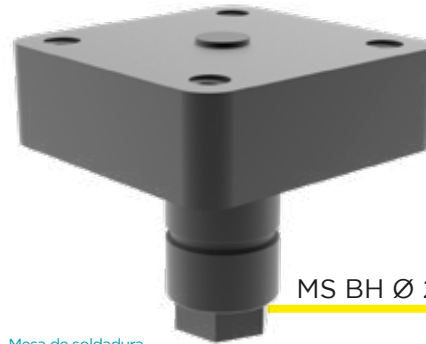
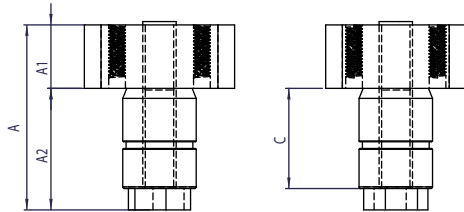

MS BH Ø 22 - KF-532

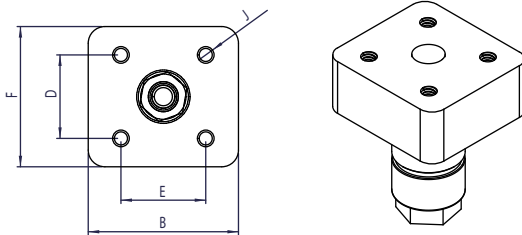

MS - Welding table  
BH - Horizontal base

MS - Mesa de soldadura  
BH - Base horizontal

REFERENCE	A (IN)	A1 (IN)	A2 (IN)	B (IN)	C (IN)	D (IN)	E (IN)	F (IN)	J (IN)	WEIGHT KG (LB)
Referencia										Peso
MS BH Ø 16 - KF-052	48,3 (1,90)	16 (0,62)	32,3 (1,27)	80 (3,14)	27 (1,06)	50 (1,96)	60 (2,36)	70 (2,75)	M10	0,56 (1,23)
MS BH Ø 22 - KF-052	55,4 (2,18)	19 (0,74)	36,4 (1,43)	80 (3,14)	30 (1,18)	50 (1,96)	60 (2,36)	71 (2,75)	M10	0,713 (1,57)
MS BH Ø 28 - KF-052	67,9 (2,67)	25,4 (1,00)	42,5 (1,67)	80 (3,14)	35 (1,37)	50 (1,96)	60 (2,36)	72 (2,75)	M10	0,997 (2,19)
MS BH Ø 16 - KF-057	48,3 (1,90)	16 (0,62)	32,3 (1,27)	50 (1,96)	27 (1,06)	35 (1,37)	40 (1,57)	55 (2,16)	M6	0,316 (0,69)
MS BH Ø 22 - KF-057	55,4 (2,18)	19 (0,74)	36,4 (1,43)	50 (1,96)	30 (1,18)	35 (1,37)	40 (1,57)	55 (2,16)	M6	0,43 (0,94)
MS BH Ø 28 - KF-057	67,9 (2,67)	25,4 (1,00)	42,5 (1,67)	50 (1,96)	35 (1,37)	35 (1,37)	40 (1,57)	55 (2,16)	M6	0,62 (1,36)
MS BH Ø 16 - KF-511	48,3 (1,90)	16 (0,62)	32,3 (1,27)	36 (1,41)	27 (1,06)	24 (0,94)	26 (1,02)	37 (1,45)	M6	0,558 (1,23)
MS BH Ø 22 - KF-511	55,4 (2,18)	19 (0,74)	36,4 (1,43)	36 (1,41)	30 (1,18)	24 (0,94)	26 (1,02)	37 (1,45)	M6	0,296 (0,65)
MS BH Ø 28 - KF-511	67,9 (2,67)	25,4 (1,00)	42,5 (1,67)	36 (1,41)	35 (1,37)	24 (0,94)	26 (1,02)	37 (1,45)	M6	0,44 (0,97)
MS BH Ø 16 - KF-521	48,3 (1,90)	16 (0,62)	32,3 (1,27)	45 (1,77)	27 (1,06)	25,4 (1,00)	24 (0,944)	42 (1,65)	M8	0,278 (0,61)
MS BH Ø 22 - KF-521	55,4 (2,18)	19 (0,74)	36,4 (1,43)	46 (1,77)	30 (1,18)	25,4 (1,00)	24 (0,944)	42 (1,65)	M8	0,38 (0,83)
MS BH Ø 28 - KF-521	67,9 (2,67)	25,4 (1,00)	42,5 (1,67)	47 (1,77)	35 (1,37)	25,4 (1,00)	24 (0,944)	42 (1,65)	M8	0,553 (1,21)
MS BH Ø 16 - KF-531	48,3 (1,90)	16 (0,62)	32,3 (1,27)	50 (1,96)	27 (1,06)	32 (1,25)	37 (1,45)	55 (2,16)	M10	0,363 (0,80)
MS BH Ø 22 - KF-531	55,4 (2,18)	19 (0,74)	36,4 (1,43)	50 (1,96)	30 (1,18)	32 (1,25)	37 (1,45)	55 (2,16)	M10	0,483 (1,06)
MS BH Ø 28 - KF-531	67,9 (2,67)	25,4 (1,00)	42,5 (1,67)	50 (1,96)	35 (1,37)	32 (1,25)	37 (1,45)	55 (2,16)	M10	0,691 (1,52)
MS BH Ø 16 - KF-532	48,3 (1,90)	16 (0,62)	32,3 (1,27)	57 (2,24)	27 (1,06)	41 (1,61)	42 (1,65)	58 (2,28)	M10	0,442 (0,97)
MS BH Ø 22 - KF-532	55,4 (2,18)	19 (0,74)	36,4 (1,43)	58 (2,24)	30 (1,18)	41 (1,61)	42 (1,65)	58 (2,28)	M10	0,577 (1,27)
MS BH Ø 28 - KF-532	67,9 (2,67)	25,4 (1,00)	42,5 (1,67)	59 (2,24)	35 (1,37)	41 (1,61)	42 (1,65)	58 (2,28)	M10	0,817 (1,80)
MS BH Ø 16 - KF-533	48,3 (1,90)	16 (0,62)	32,3 (1,27)	49 (1,92)	27 (1,06)	41 (1,61)	36 (1,41)	50 (1,96)	M8	0,448 (0,98)
MS BH Ø 22 - KF-533	55,4 (2,18)	19 (0,74)	36,4 (1,43)	49 (1,92)	30 (1,18)	41 (1,61)	36 (1,41)	50 (1,96)	M8	0,583 (1,28)
MS BH Ø 28 - KF-533	67,9 (2,67)	25,4	42,5 (1,67)	49 (1,92)	35 (1,37)	41 (1,61)	36 (1,41)	50 (1,96)	M8	0,824 (1,81)



# SQUEEZE ACTION CLAMPS ALICATES

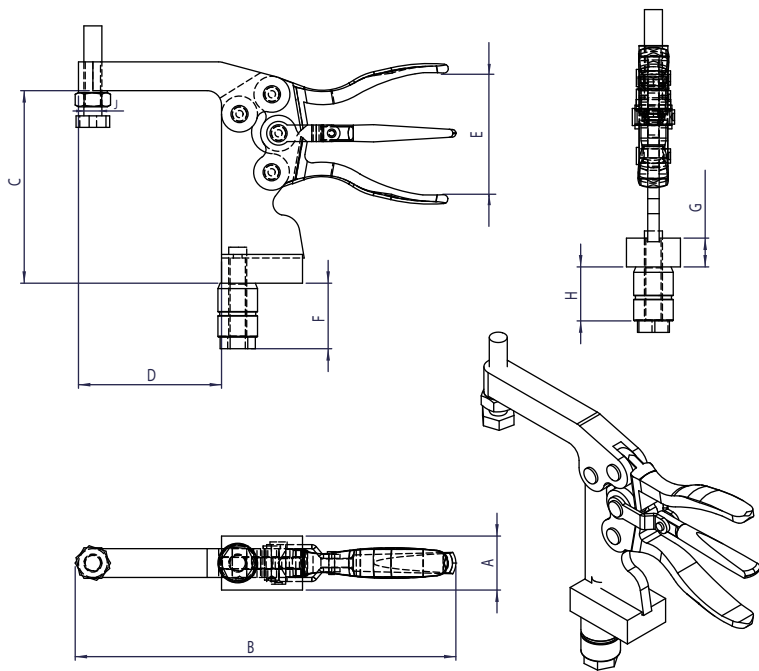

**KFA-200 MS Ø 22**



MS - Welding table

MS - Mesa de soldadura

REFERENCE Referencia	A (IN)	B (IN)	C (IN)	D (IN)	E (IN)	F (IN)	G (IN)	H (IN)	J (IN)	WEIGHT KG (LB) Peso
KFA-200 MS Ø 16	30 (1,18)	212 (8,34)	107,52 (4,23)	79,5 (3,12)	58 (2,28)	32,3 (1,27)	16 (0,62)	27 (1,06)	M10	0,945 (2,08)
KFA-200 MS Ø 22	30 (1,18)	212 (8,34)	107,52 (4,23)	79,5 (3,12)	58 (2,28)	32,3 (1,27)	16 (0,62)	30 (1,18)	M10	1,007 (2,22)
KFA-200 MS Ø 28	30 (1,18)	212 (8,34)	107,52 (4,23)	79,5 (3,12)	58 (2,28)	32,3 (1,27)	16 (0,62)	35 (1,37)	M10	1,094 (2,41)

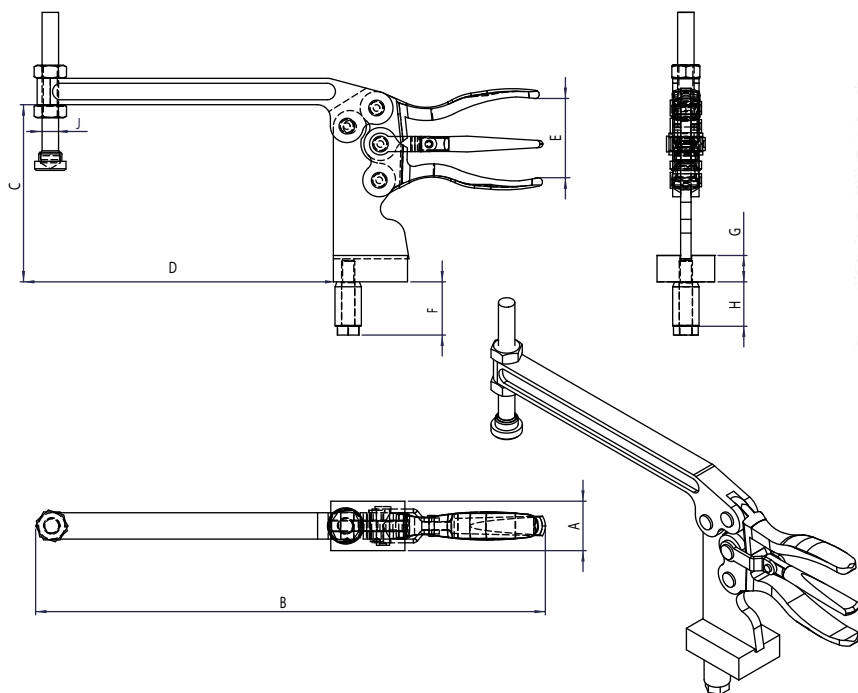

**KFA-200 L MS Ø 22**

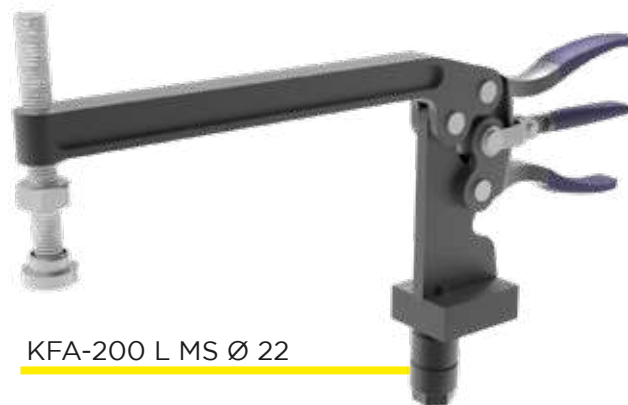

MS - Welding table  
L- Long U-Bar

MS - Mesa de soldadura  
L- Lock Plus

REFERENCE Referencia	A (IN)	B (IN)	C (IN)	D (IN)	E (IN)	F (IN)	G (IN)	H (IN)	J (IN)	WEIGHT KG (LB) Peso
KFA-200 L MS Ø 16	30 (1,18)	307 (12,08)	107,52 (4,23)	179,79 (7,07)	58 (2,28)	32,3 (1,27)	16 (0,62)	27 (1,06)	M10	1,129 (2,48)
KFA-200 L MS Ø 22	30 (1,18)	307 (12,08)	107,52 (4,23)	179,79 (7,07)	58 (2,28)	32,3 (1,27)	16 (0,62)	30 (1,18)	M10	1,18 (2,60)
KFA-200 L MS Ø 28	30 (1,18)	307 (12,08)	107,52 (4,23)	179,79 (7,07)	58 (2,28)	32,3 (1,27)	16 (0,62)	35 (1,37)	M10	1,266 (2,79)



MSSG 120X300 MM

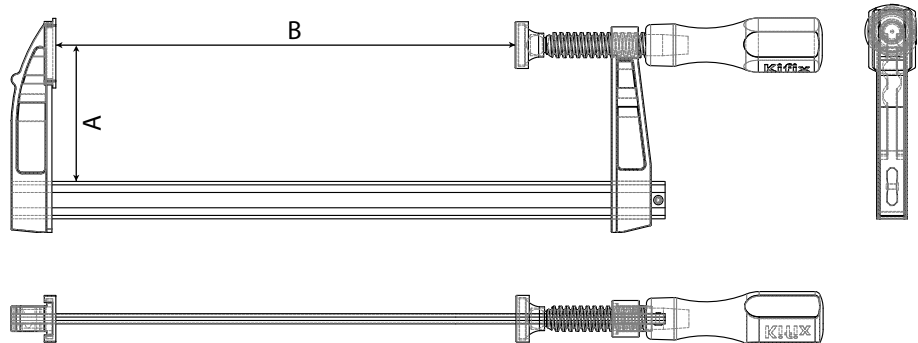
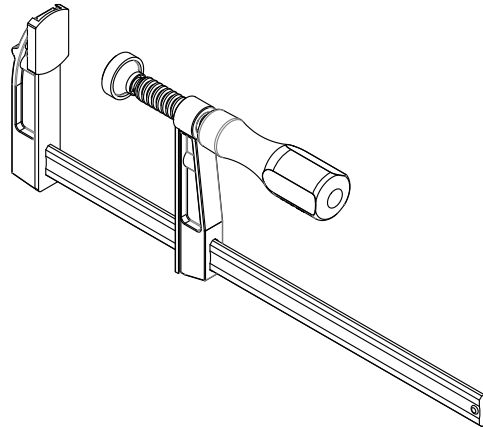

MS - Welding table  
SG - Carver Clamp

MS - Mesa de soldadura  
SG - Prensa sargento

REFERENCE Referencia	RETENTION FORCE KGF (LBF) Fuerza Retención Kgf (lbf)	A (IN)	B (IN)	WEIGHT KG (LB) Peso
KFSG 50X100 MM	1700	50 (1,96)	100 (3,93)	0,33 (0,72)
KFSG 50X150 MM	1700	50 (1,96)	150 (5,90)	0,35 (0,77)
KFSG 50X200 MM	1700	50 (1,96)	200 (7,87)	0,38 (0,83)
KFSG 50X300 MM	1700	50 (1,96)	300 (11,81)	0,42 (0,92)
KFSG 80X200 MM	2700	80 (3,14)	200 (7,87)	0,74 (1,63)
KFSG 80X300 MM	2700	81 (3,14)	300 (11,81)	0,93 (2,05)
KFSG 80X400 MM	2700	82 (3,14)	400 (15,74)	1,12 (2,46)
KFSG 80X500 MM	2700	83 (3,14)	500 (19,68)	1,31 (2,88)
KFSG 100X200 MM	3300	100 (3,93)	200 (7,87)	1,08 (2,38)
KFSG 100X400 MM	3300	100 (3,93)	400 (15,74)	1,38 (3,04)
KFSG 100X500 MM	3300	100 (3,93)	500 (19,68)	1,46 (3,21)
KFSG 100X600 MM	3300	100 (3,93)	600 (23,62)	1,58 (3,48)
KFSG 120X250 MM	4500	120 (4,72)	250 (9,84)	1,47 (3,24)
KFSG 120X300 MM	4500	120 (4,72)	300 (11,81)	1,55 (3,41)
KFSG 120X400 MM	4500	120 (4,72)	400 (15,74)	1,7 (3,74)
KFSG 120X500 MM	4500	120 (4,72)	500 (19,68)	1,85 (4,07)
KFSG 120X600 MM	4500	120 (4,72)	600 (23,62)	2 (4,40)
KFSG 120X800 MM	4500	120 (4,72)	800 (31,49)	2,29 (5,04)

# RATCHET F CLAMP PRENSA F SARGENTO



KFSR 120X300 MM

SR - Carver fast  
SR - Sargento rápido

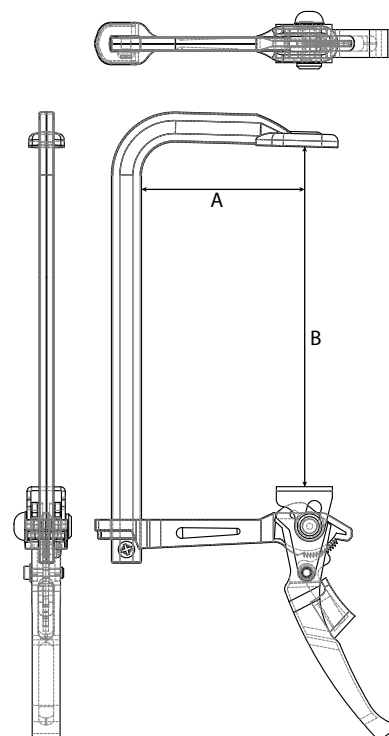
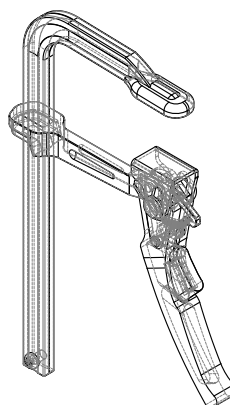

REFERENCE Referencia	RETENTION FORCE KGF (LBF) Fuerza Retención Kgf (lbf)	B (IN)	A (IN)	WEIGHT KG (LB) Peso
KFSR 60X120 MM	1600	60 (2,36)	120 (4,72)	0,46 (1,01)
KFSR 80X160 MM	1600	80 (3,14)	160 (6,29)	0,57 (1,25)
KFSR 100X200 MM	2100	100 (3,93)	200 (7,87)	1,18 (2,60)
KFSR 100X250 MM	2100	100 (3,93)	250 (9,84)	1,25 (2,75)
KFSR 100X300 MM	2100	100 (3,93)	300 (11,81)	1,38 (3,04)
KFSR 100X400 MM	2100	100 (3,93)	400 (15,74)	1,51 (3,32)
KFSR 120X250 MM	3000	120 (4,72)	250 (9,84)	1,45 (3,19)
KFSR 120X300 MM	3000	120 (4,72)	300 (11,81)	1,53 (3,37)
KFSR 120X400 MM	3700	120 (4,72)	400 (15,74)	2,49 (5,48)
KFSR 120X500 MM	3700	120 (4,72)	500 (19,68)	2,7 (5,95)
KFSR 120X600 MM	3700	120 (4,72)	600 (23,62)	2,91 (6,41)

# C CLAMP PRENSA C

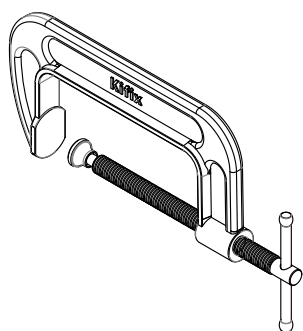

KFSC 3 POL (75 MM)



SC - Clamp C  
SC - Prensa C

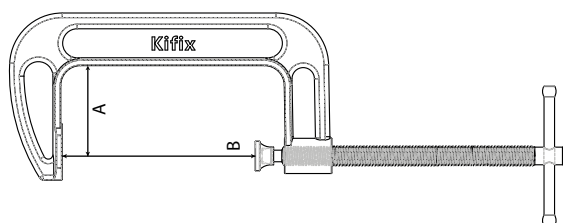
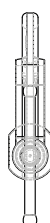

REFERENCE Referencia	RETENTION FORCE KGF (LBF) Fuerza Retención Kgf (lbf)	A (IN)	B (IN)	WEIGHT KG (LB) Peso
KFSC 1 POL (25MM)	1000	25 (0,98)	25 (0,98)	0,09 (1,19)
KFSC 2 POL (50MM)	2300	26 (1,02)	50 (1,96)	0,175 (0,38)
KFSC 3 POL (75MM)	5500	50 (1,96)	75 (2,95)	0,44 (0,97)
KFSC 4 POL (100MM)	7000	60 (2,36)	100 (3,93)	0,64 (1,41)
KFSC 5 POL (125MM)	7500	67 (2,63)	125 (4,92)	0,95 (2,09)
KFSC 6 POL (150MM)	9000	72 (2,83)	150 (5,90)	1,23 (2,71)
KFSC 8 POL (200MM)	10000	88 (3,46)	200 (7,87)	1,79 (3,94)

## More than 15 years of experience in the market Más de 15 años de experiencia en el mercado

### • RAW MATERIAL MATERIA PRIMA

We make cuts in carbon up to 25.4mm and stainless steel up to 12mm. Special materials are cut upon request. We also have a diversified stock of raw materials, speeding delivery according to customer needs.

Realizamos cortes en carbono hasta 25,4mm y acero inoxidable hasta 12mm. se cortan materiales especiales bajo pedido. También tenemos un stock diversificado de materias primas, agilizando la entrega según las necesidades del cliente.

### SERVICIO COMPLETO **FULL SERVICE** •

In addition to cutting, we offer bending and painting, we deliver the complete set to you!

Además de cortar, ofrecemos doblado y pintura, te entregamos el juego completo!

### • CUTTING-EDGE MACHINES MÁQUINAS DE ÚLTIMA GENERACIÓN

We have two high-performance Trumpf 1030 machines, one of the best on the market. Benefit from our service, contact us to cut your pieces.

Disponemos de dos máquinas Trumpf 1030 de altas prestaciones, una de las mejores del mercado. Beneficiate de nuestro servicio, contáctanos para cortar tus piezas.



Direct contact laser cutting / Corte por láser de contacto directo  (54) 99991.2831



## Official distributor of siegmund in Brazil Distribuidor oficial de siegmund en Brasil

Siegmund is a German company, a world leader in the manufacture of welding tables and welding clamping systems. Kifix Tools is the national distributor with service and delivery throughout the country.

Siegmund es una empresa alemana líder mundial en la fabricación de mesas de soldadura y sistemas de sujeción para soldadura. Kifix Tools es el distribuidor nacional con servicio y entrega en todo el país.



### WELDING TABLE 16MM MESAS DE SOLDADURA 16MM



**BASIC 16**  
**PROFESSIONAL 750**  
**EXTREME 8.7**  
**EXTREME 8.7 PLUS**

\*Representative image of the Basic 16 Table  
\*Imagen representativa de la mesa Basic 16



### WELDING TABLES 22MM MESAS DE SOLDADURA 22MM



**PROFESSIONAL 750**  
**EXTREME 8.7**  
**EXTREME 8.7 PLUS**

\*Representative image of the Professional 750 Table  
\*Imagen representativa de la mesa Professional 750



### WELDING TABLES 28MM MESAS DE SOLDADURA 28MM



**BASIC 28**  
**PROFESSIONAL 750**  
**PROFESSIONAL EXTREME**  
**EXTREME 8.8 PLUS**

\*Representative image of the Basic 28 Table  
\*Imagen representativa de la mesa Basic 28

### ACCESSORIES ACCESORIOS



\*Examples of some of the available accessories  
\*Ejemplos de algunos de los accesorios disponibles.



Direct contact welding tables / Mesas de soldadura por contacto directo  (54) 99649.4038



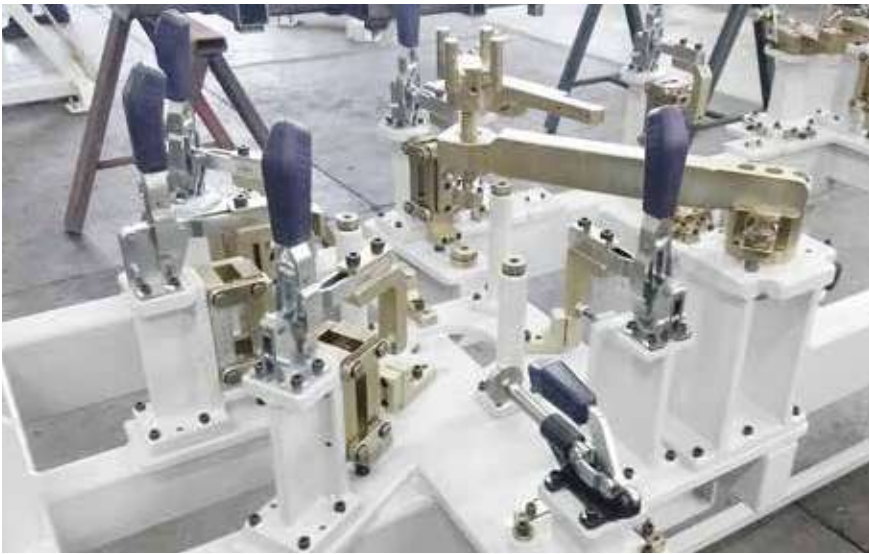

WE ALSO HAVE  
stainless  
steel clamps &  
toggle-lock clamps

Fabricamos en acero  
inoxidable y con bloqueo



**CLAMPS APPLICATIONS** APLICACIONES DE PRENSAS

**TOGGLE CLAMP**  
**CLAMPING FAST**  
**ROBUSTNESS**  
**AGILITY**

**PRESAS RAPIDAS**

**SETUP RAPIDO**

**ROBUSTEZ**

**AGILIDAD**

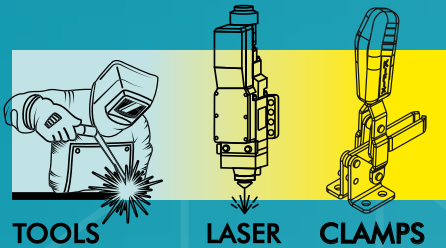

**Kifix**®  
G R O U P  
G R U P O



**ACCESS / ACCESO :**



**KIFIX INDÚSTRIA E COMÉRCIO LTDA.**

Phone/ Teléfono: +55 54 3028.4614/3028.4615 | [kifix@kifix.com.br](mailto:kifix@kifix.com.br)

Street /Calle: Gov. Roberto Silveira, 899 - Santa Catarina

ZIP CODE/CEP 95032-710 - Caxias do Sul | RS | Brazil / Brasil